

Agilent 5975 Series MSD

Troubleshooting and Maintenance Manual

Notices

© Agilent Technologies, Inc. 2012

No part of this manual may be reproduced in any form or by any means (including electronic storage and retrieval or translation into a foreign language) without prior agreement and written consent from Agilent Technologies, Inc. as governed by United States and international copyright laws.

Manual Part Number

G3170-90037

Edition

Fourth edition, January 2012
Replaces G3170-90021

Printed in USA

Agilent Technologies, Inc.
5301 Stevens Creek Boulevard
Santa Clara, CA 95052

Warranty

The material contained in this document is provided “as is,” and is subject to being changed, without notice, in future editions. Further, to the maximum extent permitted by applicable law, Agilent disclaims all warranties, either express or implied, with regard to this manual and any information contained herein, including but not limited to the implied warranties of merchantability and fitness for a particular purpose. Agilent shall not be liable for errors or for incidental or consequential damages in connection with the furnishing, use, or performance of this document or of any information contained herein. Should Agilent and the user have a separate written agreement with warranty terms covering the material in this document that conflict with these terms, the warranty terms in the separate agreement shall control.

Safety Notices

CAUTION

A **CAUTION** notice denotes a hazard. It calls attention to an operating procedure, practice, or the like that, if not correctly performed or adhered to, could result in damage to the product or loss of important data. Do not proceed beyond a **CAUTION** notice until the indicated conditions are fully understood and met.

WARNING

A **WARNING** notice denotes a hazard. It calls attention to an operating procedure, practice, or the like that, if not correctly performed or adhered to, could result in personal injury or death. Do not proceed beyond a **WARNING** notice until the indicated conditions are fully understood and met.

Contents

1 Introduction

5975 Series MSD Version	10
Abbreviations Used	11
The 5975 Series MSD	13
MSD Hardware Description	15
Electron Ionization (EI) systems	16
Chemical Ionization (CI) systems	16
Changing modes	17
Important Safety Warnings	18
Hydrogen Safety	20
Safety and Regulatory Certifications	25
Cleaning/Recycling the Product	28
Moving or Storing the MSD	28

2 General Troubleshooting

Troubleshooting Tips and Tricks	30
General Symptoms	31
Chromatographic Symptoms	33
Mass Spectral Symptoms	38
Pressure Symptoms	42
Temperature Symptoms	45
Error Messages	47
Air Leaks	53
Contamination	54

3 CI Troubleshooting

Common CI-Specific Problems	58
Troubleshooting Tips and Tricks	59
Air Leaks	60
Pressure-Related Symptoms	64
Signal-Related Symptoms	68
Tuning-Related Symptoms	77

4 General Maintenance

Before Starting	84
Maintaining the Vacuum System	89
To Remove the MSD Covers	90
To Connect the Micro-Ion Vacuum Gauge	92
To Move or Store the MSD	94
To Check and Add Foreline Pump Oil	96
To Drain the Foreline Pump	98
To Refill the Foreline Pump	100
To Check the Diffusion Pump Fluid	101
To Separate the MSD from the GC	103
To Reconnect the MSD to the 7890A GC/7820A/6890 GC	105
To Reconnect the MSD to the 6850 GC	106
To Refill the EI Calibration Vial	109
To Purge the Calibration Valves	111
To Remove the EI Calibration and Vent Valve Assembly	112
To Reinstall the EI Calibration and Vent Valve Assembly	113
To Replace the Fan for the High Vacuum Pump	114

To Remove the Micro-Ion Vacuum Gauge	116
To Reinstall a Micro-Ion Vacuum Gauge	117
To Lubricate the Side Plate O-Ring	118
To Lubricate the Vent Valve O-Ring	120
To Remove the Diffusion Pump	122
To Replace the Diffusion Pump Fluid	124
To Reinstall the Diffusion Pump	127
To Remove the Foreline Gauge	129
To Reinstall the Foreline Gauge	130
Maintaining the Analyzer	131
Maintaining the GC/MSD Interface	153
Maintaining the Electronics	157

5 CI Maintenance

To Clean the CI Ion Source	164
To Minimize Foreline Pump Damage from Ammonia (Standard Pump)	166
To Replace the Methane/Isobutane Gas Purifier	167
To Clean the Reagent Gas Supply Lines	168
To Refill the CI Calibrant Vial	169

6 Vacuum System

Overview	172
Vacuum System Components	173
Common Vacuum System Problems	174
Foreline Pump	175
High Vacuum Pump	178

Diffusion pump system	178
Turbo pump system	178
Analyzer Chamber	179
Diffusion pump version	179
Turbo pump version	179
Side Plate	180
Vacuum Seals	182
Foreline Gauge	184
Diffusion Pump and Fan	185
Turbo Pump and Fan	191
Calibration Valves and Vent Valve	192
Micro-Ion Vacuum Gauge	195

7 Analyzer

Overview	198
El Ion Source	200
Cl Ion Source	202
Filaments	204
Other Source Elements	206
Quadrupole Mass Filter	208
Detector	211
Analyzer Heaters and Radiators	213

8 Electronics

Local Control Panel and Power Switch	217
Side Board	218
Electronics Module	219

LAN/MS Control Card	223
Power Supplies	224
Back Panel and Connectors	225
Interfacing to External Devices	228

9 Parts

To Order Parts	232
Electronics	233
Local Control Panel	238
Vacuum System	240
Analyzer	250
EI GC/MSD Interface	259
Consumables and Maintenance Supplies	260
CI Parts	265
Index	271

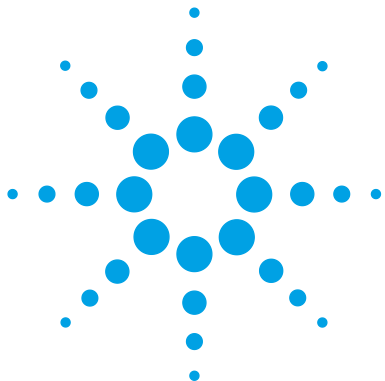

1 Introduction

5975 Series MSD Version	10
Abbreviations Used	11
The 5975 Series MSD	13
Physical description	13
Local control panel	13
Vacuum gauge	13
MSD Hardware Description	15
Important Safety Warnings	18
Many internal parts of the MSD carry dangerous voltages	18
Electrostatic discharge is a threat to MSD electronics	18
Many parts are dangerously hot	19
The oil pan under the standard foreline pump can be a fire hazard	19
Hydrogen Safety	20
Dangers unique to GC/MSD operation	21
Hydrogen accumulation in an MSD	21
Precautions	23
Safety and Regulatory Certifications	25
Information	25
Symbols	26
Electromagnetic compatibility	27
Sound emission declaration	27
Cleaning/Recycling the Product	28
Moving or Storing the MSD	28

This manual describes the troubleshooting and maintenance of the Agilent Technologies 5975 Series Mass Selective Detector (MSD). It assumes familiarity with the procedures and information detailed in the 5975 Series MSD Operation Manual and with the Agilent MSD ChemStation software.



5975 Series MSD Version

5975 Series MSDs are equipped with a diffusion pump or one of two turbomolecular (turbo) pumps. The serial number label displays a product number (Table 1) that indicates what kind of MSD you have.

Table 1 Available high vacuum pumps

Model name	Product number	Description	Ionization modes
5975C TAD VL MSD	G3170A	Diffusion Pump MSD	Electron impact (EI)
5975C TAD inert MSD	G3171A	Standard Turbo MSD	Electron impact (EI)
5975C TAD inert XL MSD	G3172A	Performance Turbo MSD	Electron impact (EI)
5975C TAD inert XL EI/CI MSD	G3174A	CI Performance Turbo Pump	Electron impact (EI) Negative chemical ionization (NCI) Positive chemical ionization (PCI)
7820 VL MSD	G3175A	Diffusion Pump MSD	Electron impact (EI)
7820 MSD	G3176A	Standard Turbo MSD	Electron impact (EI)

Abbreviations Used

The abbreviations in [Table 2](#) are used in discussing this product. They are collected here for convenience.

Table 2 Abbreviations

Abbreviation	Definition
AC	Alternating current
ALS	Automatic liquid sampler
BFB	Bromofluorobenzene (calibrant)
CI	Chemical ionization
DC	Direct current
DFTPP	Decafluorotriphenylphosphine (calibrant)
DIP	Direct insertion probe
DP	Diffusion pump
EI	Electron impact ionization
EM	Electron multiplier (detector)
EMV	Electron multiplier voltage
EPC	Electronic pneumatic control
eV	Electron volt
GC	Gas chromatograph
HED	High-energy dynode (refers to detector and its power supply)
id	Inside diameter
LAN	Local Area Network
LCP	Local control panel (on the MSD)
<i>m/z</i>	Mass to charge ratio
MFC	Mass flow controller
MSD	Mass Selective Detector

Table 2 Abbreviations (continued)

Abbreviation	Definition
NCI	Negative CI
OFN	Octafluoronaphthalene (calibrant)
PCI	Positive CI
PFDTD	Perfluoro-5,8-dimethyl-3,6,9-trioxydodecane (calibrant)
PFHT	2,4,6-tris(perfluoroheptyl)-1,3,5-triazine (calibrant)
PFTBA	Perfluorotributylamine (calibrant)
Quad	Quadrupole mass filter
RF	Radio frequency
RFPA	Radio frequency power amplifier
Torr	Unit of pressure, 1 mm Hg
Turbo	Turbomolecular (pump)

The 5975 Series MSD

The 5975 Series MSD is a stand-alone capillary GC detector for use with Agilent Gas Chromatographs (Table 3). The MSD features:

- Local Control Panel (LCP) for locally monitoring and operating the MSD
- One of three different high vacuum pumps
- Rotary vane foreline pump
- Independently MSD heated electron-ionization ion source
- Independently MSD heated hyperbolic quadrupole mass filter
- High-energy dynode (HED) electron multiplier detector
- Independently GC heated GC/MSD interface
- Chemical ionization (EI/PCI/NCI) modes available

Physical description

The 5975 Series MSD is a rectangular box, approximately 42 cm high, 26 cm wide, and 65 cm deep. The weight is 25 kg for the diffusion pump mainframe, 26 kg for the standard turbo pump mainframe, and 29 kg for the performance turbo pump mainframe. The attached foreline (roughing) pump weighs an additional 11 kg (standard pump).

The basic components of the instrument are: the frame/cover assemblies, the local control panel, the vacuum system, the GC interface, the electronics, and the analyzer.

Local control panel

The local control panel allows local monitoring and operation of the MSD. You can tune the MSD, run a method or a sequence, and monitor instrument status.

Vacuum gauge

The 5975 Series MSD may be equipped with a Micro-Ion Vacuum Gauge. The MSD ChemStation can be used to read the pressure (high vacuum) in the vacuum manifold. Installation of the gauge controller is described in this manual.

The gauge is **required** for chemical ionization (CI) operation.

Table 3 5975 series MSD models and features

Feature	Model			
	G3170A G3175A	G3171A G3176A	G3172A	G3174A
High vacuum pump	Diffusion	Standard turbo	Performance turbo	Performance turbo
Optimal He column flow mL/min	1	1	1 to 2	1 to 2
Maximum recommended gas flow mL/min*	1.5	2.0	4.0	4
Maximum gas flow, mL/min [†]	2	2.4	6.5	6.5
Max column id	0.25 mm (30 m)	0.32 mm (30 m)	0.53 mm (30 m)	0.53 mm (30 m)
CI capability	No	No	No	Yes
DIP [‡] capability (3rd party)	Yes	Yes	Yes	Yes

* Total gas flow into the MSD: column flow plus reagent gas flow (if applicable).

† Expect degradation of spectral performance and sensitivity.

‡ Direct insertion probe.

MSD Hardware Description

Figure 1 is an overview of a typical GC/MSD system.

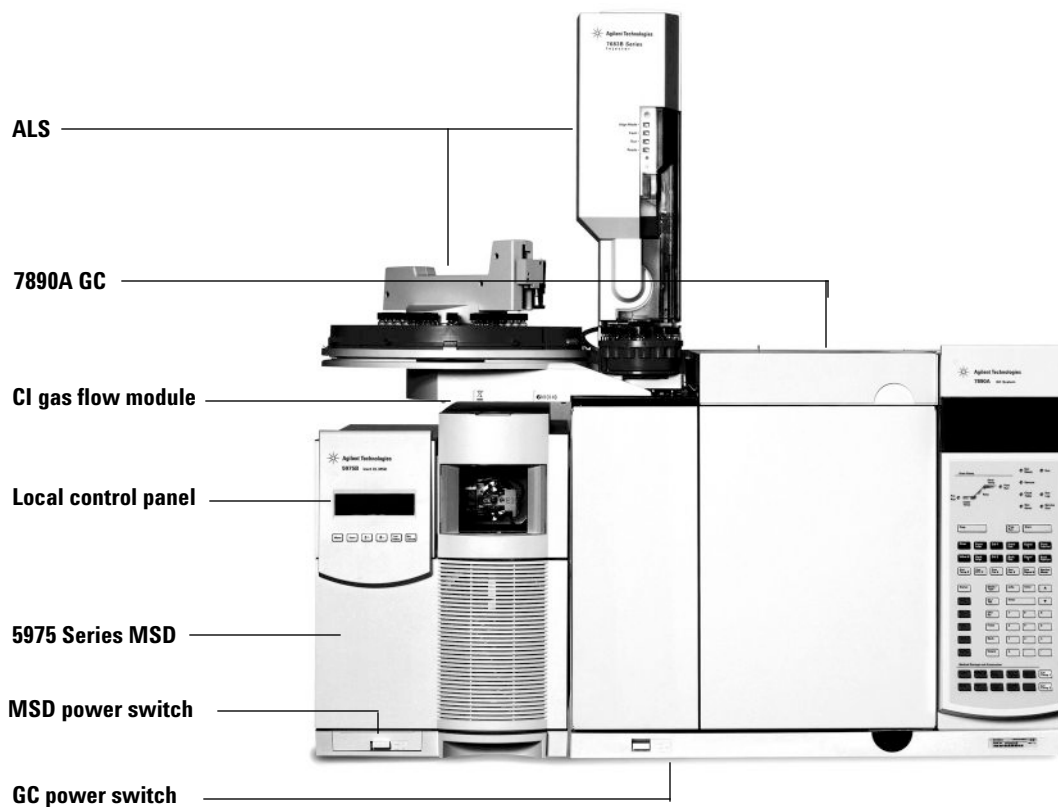

Figure 1 5975 Series GC/MSD system

Electron Ionization (EI) systems

EI systems ionize sample molecules by bombarding them with electrons. The ions, including fragments, are drawn into the quadrupole analyzer where they are separated by their mass-to-charge (m/z) ratios and detected.

Chemical Ionization (CI) systems

CI systems use a reagent gas as an intermediate between the electrons and the sample. CI is more gentle than direct electron bombardment.

The CI hardware allows the 5975 Series MSD to produce high-quality, classical CI spectra, which include molecular adduct ions. A variety of reagent gases can be used.

In this manual, the term “CI MSD” refers to the G3174A MSD and upgraded G3172A MSDs. It also applies, unless otherwise specified, to the flow modules for these instruments.

The 5975 Series CI system adds to the 5975 Series MSD:

- EI/CI GC/MSD interface
- CI ion source and interface tip seal
- Reagent gas flow control module
- Bipolar HED power supply for PCI and NCI operation

A methane/isobutane gas purifier is provided and is **required**. It removes oxygen, water, hydrocarbons, and sulfur compounds.

A high vacuum gauge controller (G3397A) is **required** for CI MSD and is recommended for EI also.

The MSD CI system has been optimized to achieve the relatively high source pressure required for CI while still maintaining high vacuum in the quadrupole and detector. Special seals along the flow path of the reagent gas and very small openings in the ion source keep the source gases in the ionization volume long enough for the appropriate reactions to occur.

The CI interface has special plumbing for reagent gas. A spring-loaded insulating seal fits onto the tip of the interface.

Changing modes

Switching back and forth between CI and EI sources takes less than an hour, although a 1- to 2-hour wait is required to purge the reagent gas lines and bake out water and other contaminants. Switching from PCI to NCI requires about 2 hours for the ion source to cool.

Important Safety Warnings

There are several important safety notices to always keep in mind when using the MSD.

Many internal parts of the MSD carry dangerous voltages

If the MSD is connected to a power source, even if the power switch is off, potentially dangerous voltages exist on:

- The wiring between the MSD power cord and the AC power supply, the AC power supply itself, and the wiring from the AC power supply to the power switch.

With the power switch on, potentially dangerous voltages also exist on:

- All electronics boards in the instrument.
- The internal wires and cables connected to these boards.
- The wires for any heater (oven, detector, inlet, or valve box).

WARNING

All these parts are shielded by covers. With the covers in place, it should be difficult to accidentally make contact with dangerous voltages. Unless specifically instructed to, never remove a cover unless the detector, inlet, or oven are turned off.

WARNING

If the power cord insulation is frayed or worn, the cord must be replaced. Contact your Agilent service representative.

Electrostatic discharge is a threat to MSD electronics

The printed circuit boards in the MSD can be damaged by electrostatic discharge. Do not touch any of the boards unless it is absolutely necessary. If you must handle them, wear a grounded wrist strap and take other antistatic precautions. Wear a grounded wrist strap any time you must remove the MSD right side cover.

Many parts are dangerously hot

Many parts of the GC/MSD operate at temperatures high enough to cause serious burns. These parts include but are not limited to:

- The inlets
- The oven and its contents
- The detector
- The column nuts attaching the column to an inlet or detector
- The valve box
- The foreline pump

Always cool these areas of the system to room temperature before working on them. They will cool faster if you first set the temperature of the heated zone to room temperature. Turn the zone off after it has reached the setpoint. If you must perform maintenance on hot parts, use a wrench and wear gloves. Whenever possible, cool the part of the instrument that you will be maintaining before you begin working on it.

WARNING

Be careful when working behind the instrument. During cool-down cycles, the GC emits hot exhaust which can cause burns.

WARNING

The insulation around the inlets, detectors, valve box, and the insulation cups is made of refractory ceramic fibers. To avoid inhaling fiber particles, we recommend the following safety procedures: ventilate your work area; wear long sleeves, gloves, safety glasses, and a disposable dust/mist respirator; dispose of insulation in a sealed plastic bag; wash your hands with mild soap and cold water after handling the insulation.

The oil pan under the standard foreline pump can be a fire hazard

Oily rags, paper towels, and similar absorbents in the oil pan could ignite and damage the pump and other parts of the MSD.

WARNING

Combustible materials (or flammable/non-flammable wicking material) placed under, over, or around the foreline (roughing) pump constitutes a fire hazard. Keep the pan clean, but do not leave absorbent material such as paper towels in it.

Hydrogen Safety

WARNING

The use of hydrogen as a GC carrier gas is potentially dangerous.

WARNING

When using hydrogen (H₂) as the carrier gas or fuel gas, be aware that hydrogen gas can flow into the GC oven and create an explosion hazard. Therefore, be sure that the supply is turned off until all connections are made and ensure that the inlet and detector column fittings are either connected to a column or capped at all times when hydrogen gas is supplied to the instrument.

Hydrogen is flammable. Leaks, when confined in an enclosed space, may create a fire or explosion hazard. In any application using hydrogen, leak test all connections, lines, and valves before operating the instrument. Always turn off the hydrogen supply at its source before working on the instrument.

Hydrogen is a commonly used GC carrier gas. Hydrogen is potentially explosive and has other dangerous characteristics.

- Hydrogen is combustible over a wide range of concentrations. At atmospheric pressure, hydrogen is combustible at concentrations from 4% to 74.2% by volume.
- Hydrogen has the highest burning velocity of any gas.
- Hydrogen has a very low ignition energy.
- Hydrogen that is allowed to expand rapidly from high pressure can self-ignite.
- Hydrogen burns with a nonluminous flame which can be invisible under bright light.

Additional information can be found in the *Hydrogen Safety Guide* which is included on the Agilent GC/GCMSD Hardware User Information & Instrument Utilities DVD.

Dangers unique to GC/MSD operation

Hydrogen presents a number of dangers. Some are general, others are unique to GC or GC/MSD operation. Dangers include, but are not limited to:

- Combustion of leaking hydrogen.
- Combustion due to rapid expansion of hydrogen from a high-pressure cylinder.
- Accumulation of hydrogen in the GC oven and subsequent combustion (see your GC documentation and the label on the top edge of the GC oven door).
- Accumulation of hydrogen in the MSD and subsequent combustion.

Hydrogen accumulation in an MSD

WARNING

The MSD cannot detect leaks in inlet and/or detector gas streams. For this reason, it is vital that column fittings should always be either connected to a column or have a cap or plug installed.

All users should be aware of the mechanisms by which hydrogen can accumulate (Table 4) and know what precautions to take if they know or suspect that hydrogen has accumulated. Note that these mechanisms apply to *all* mass spectrometers, including the MSD.

Table 4 Hydrogen accumulation mechanisms

Mechanism	Results
Mass spectrometer turned off	A mass spectrometer can be shut down deliberately. It can also be shut down accidentally by an internal or external failure. A mass spectrometer shutdown does not shut off the flow of carrier gas. As a result, hydrogen may slowly accumulate in the mass spectrometer.

Table 4 Hydrogen accumulation mechanisms (continued)

Mechanism	Results
Mass spectrometer automated shutoff valves closed	Some mass spectrometers are equipped with automated diffusion pump shutoff valves. In these instruments, deliberate operator action or various failures can cause the shutoff valves to close. shutoff valve closure does not shut off the flow of carrier gas. As a result, hydrogen may slowly accumulate in the mass spectrometer.
Mass spectrometer manual shutoff valves closed	Some mass spectrometers are equipped with manual diffusion pump shutoff valves. In these instruments, the operator can close the shutoff valves. Closing the shutoff valves does not shut off the flow of carrier gas. As a result, hydrogen may slowly accumulate in the mass spectrometer.
GC off	A GC can be shut down deliberately. It can also be shut down accidentally by an internal or external failure. Different GCs react in different ways. If a 6890 GC equipped with Electronic Pressure Control (EPC) is shut off, the EPC stops the flow of carrier gas. If the carrier flow is not under EPC control, the flow increases to its maximum. This flow may be more than some mass spectrometers can pump away, resulting in the accumulation of hydrogen in the mass spectrometer. If the mass spectrometer is shut off at the same time, the accumulation can be fairly rapid.
Power failure	If the power fails, both the GC and mass spectrometer shut down. The carrier gas, however, is not necessarily shut down. As described previously, in some GCs a power failure may cause the carrier gas flow to be set to maximum. As a result, hydrogen may accumulate in the mass spectrometer.

WARNING

Once hydrogen has accumulated in a mass spectrometer, extreme caution must be used when removing it. Incorrect startup of a mass spectrometer filled with hydrogen can cause an explosion.

WARNING

After a power failure, the mass spectrometer may start up and begin the pumpdown process by itself. This does not guarantee that all hydrogen has been removed from the system or that the explosion hazard has been removed.

Precautions

Take the following precautions when operating a GC/MSD system with hydrogen carrier gas.

Equipment precaution

You **MUST** make sure the front side-plate thumbscrew is fastened finger-tight. Do not overtighten the thumbscrew; it can cause air leaks.

WARNING

Failure to secure your MSD as described above greatly increases the chance of personal injury in the event of an explosion.

You must remove the plastic cover over the glass window on the front of a 5975 MSD. In the unlikely event of an explosion, this cover may dislodge.

General laboratory precautions

- Avoid leaks in the carrier gas lines. Use leak-checking equipment to periodically check for hydrogen leaks.
- Eliminate from your laboratory as many ignition sources as possible (open flames, devices that can spark, sources of static electricity, etc.).
- Do not allow hydrogen from a high pressure cylinder to vent directly to atmosphere (danger of self-ignition).
- Use a hydrogen generator instead of bottled hydrogen.

Operating precautions

- Turn off the hydrogen at its source every time you shut down the GC or MSD.
- Turn off the hydrogen at its source every time you vent the MSD (do not heat the capillary column without carrier gas flow).
- Turn off the hydrogen at its source every time shutoff valves in an MSD are closed (do not heat the capillary column without carrier gas flow).
- Turn off the hydrogen at its source if a power failure occurs.
- If a power failure occurs while the GC/MSD system is unattended, even if the system has restarted by itself:
 - 1 Immediately turn off the hydrogen at its source.
 - 2 Turn off the GC.
 - 3 Turn off the MSD and allow it to cool for 1 hour.
 - 4 Eliminate **all** potential sources of ignition in the room.
 - 5 Open the vacuum manifold of the MSD to atmosphere.
 - 6 Wait at least 10 minutes to allow any hydrogen to dissipate.
 - 7 Start up the GC and MSD as normal.

When using hydrogen gas, check the system for leaks to prevent possible fire and explosion hazards based on local Environmental Health and Safety (EHS) requirements. Always check for leaks after changing a tank or servicing the gas lines. Always make sure the vent line is vented into a fume hood.

Safety and Regulatory Certifications

The 5975 Series MSD conforms to the following safety standards:

- Canadian Standards Association (CSA): CAN/CSA-C222 No. 61010-1-04
- CSA/Nationally Recognized Test Laboratory (NRTL): UL 61010-1
- International Electrotechnical Commission (IEC): 61010-1
- EuroNorm (EN): 61010-1

The 5975 Series MSD conforms to the following regulations on Electromagnetic Compatibility (EMC) and Radio Frequency Interference (RFI):

- CISPR 11/EN 55011: Group 1, Class A
- IEC/EN 61326
- AUS/NZ 

This ISM device complies with Canadian ICES-001. Cet appareil ISM est conforme a la norme NMB-001 du Canada.



The 5975 Series MSD is designed and manufactured under a quality system registered to ISO 9001.

Information

The Agilent Technologies 5975 Series MSD meets the following IEC (International Electro-technical Commission) classifications: Equipment Class I, Laboratory Equipment, Installation Category II, Pollution Degree 2.

This unit has been designed and tested in accordance with recognized safety standards and is designed for use indoors. If the instrument is used in a manner not specified by the manufacturer, the protection provided by the instrument may be impaired. Whenever the safety protection of the MSD has been compromised, disconnect the unit from all power sources and secure the unit against unintended operation.

Refer servicing to qualified service personnel. Substituting parts or performing any unauthorized modification to the instrument may result in a safety hazard.

Symbols

Warnings in the manual or on the instrument must be observed during all phases of operation, service, and repair of this instrument. Failure to comply with these precautions violates safety standards of design and the intended use of the instrument. Agilent Technologies assumes no liability for the customer's failure to comply with these requirements.

See accompanying instructions for more information.



Indicates a hot surface.



Indicates hazardous voltages.



Indicates earth (ground) terminal.



Indicates potential explosion hazard.



Indicates radioactivity hazard.



Indicates electrostatic discharge hazard.



Indicates that you must not discard this electrical/electronic product in domestic household waste.



Electromagnetic compatibility

This device complies with the requirements of CISPR 11. Operation is subject to the following two conditions:

- This device may not cause harmful interference.
- This device must accept any interference received, including interference that may cause undesired operation.

If this equipment does cause harmful interference to radio or television reception, which can be determined by turning the equipment off and on, the user is encouraged to try one or more of the following measures:

- 1 Relocate the radio or antenna.
- 2 Move the device away from the radio or television.
- 3 Plug the device into a different electrical outlet, so that the device and the radio or television are on separate electrical circuits.
- 4 Make sure that all peripheral devices are also certified.
- 5 Make sure that appropriate cables are used to connect the device to peripheral equipment.
- 6 Consult your equipment dealer, Agilent Technologies, or an experienced technician for assistance.
- 7 Changes or modifications not expressly approved by Agilent Technologies could void the user's authority to operate the equipment.

Sound emission declaration

Sound pressure

Sound pressure $L_p < 70$ dB according to EN 27779:1991.

Schalldruckpegel

Schalldruckpegel $L_P < 70$ dB am nach EN 27779:1991.

Cleaning/Recycling the Product

To clean the unit, disconnect the power and wipe down with a damp, lint-free cloth. For recycling, contact your local Agilent sales office.

Moving or Storing the MSD

The best way to keep your MSD functioning properly is to keep it pumped down and hot, with carrier gas flow. If you plan to move or store your MSD, a few additional precautions are required. The MSD must remain upright at all times; this requires special caution when moving. The MSD should not be left vented to atmosphere for long periods.

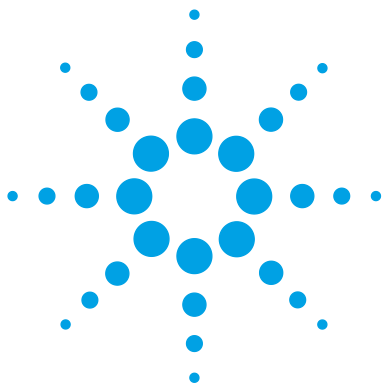

2 General Troubleshooting

Troubleshooting Tips and Tricks	30
General Symptoms	31
Chromatographic Symptoms	33
Mass Spectral Symptoms	38
Pressure Symptoms	42
Temperature Symptoms	45
Error Messages	47
Air Leaks	53
Contamination	54

How to identify the symptoms and causes of problems in your MSD.

This is a quick reference to symptoms and possible causes of the most common problems experienced by users. See “[CI Troubleshooting](#)” on page 57 for help with CI-specific problems. For each symptom, one or more possible causes are listed. In general, the causes listed first are the most likely causes **or** the easiest to check and correct.

NOTE

This chapter does not include corrective actions for the possible causes listed. Some of the corrective actions required may be dangerous if performed incorrectly. Do not attempt any corrective actions unless you are sure you know the correct procedure and the dangers involved. See the *Troubleshooting* section in the online help and the other chapters in this manual for more information.

If the material in this chapter and in the online help proves insufficient to help you diagnose a problem, contact your Agilent Technologies service representative.



Troubleshooting Tips and Tricks

Rule 1: “Look for what has been changed.”

Many problems are introduced accidentally by human actions. Every time any system is disturbed, there is a chance of introducing a new problem.

- If the MSD was just pumped down after maintenance, suspect air leaks or incorrect assembly.
- If carrier gas or helium gas purifier were just changed, suspect leaks or contaminated or incorrect gas.
- If the GC column was just replaced, suspect air leaks or contaminated or bleeding column.

Rule 2: “If complex isn’t working, go back to simple.”

A complex task is not only more difficult to perform but also more difficult to troubleshoot. If you’re having trouble detecting your sample, verify that autotune is successful.

Rule 3: “Divide and conquer.”

This technique is known as “half-split” troubleshooting. If you can isolate the problem to only part of the system, it is much easier to locate.

- To determine whether an air leak is in the GC or the MSD, you can vent the MSD, remove the column, and install the blank interface ferrule. If the leak goes away, it was in the GC.

General Symptoms

This section describes symptoms you might observe when first turning on the GC/MSD system. All of these symptoms would prevent operation of the system.

GC does not turn on

Nothing happens when the GC is switched on. The GC fans do not turn on and the keypad display does not light.

- Disconnected GC power cord
- No voltage or incorrect voltage at the electrical outlet
- Failed fuse in the GC
- GC power supply is not working correctly

MSD does not turn on

Nothing happens when the MSD is switched on. The foreline pump does not start. The cooling fan for the high vacuum pump does not turn on. The local control panel is not on.

- Disconnected MSD power cord
- No voltage or incorrect voltage at the electrical outlet
- Failed primary fuses
- MSD electronics are not working correctly

Foreline pump is not operating

The MSD is receiving power (the fan is operating and the local control panel is lit) but the foreline pump is not operating.

- Large air leak (usually the analyzer door open) has caused pumpdown failure. See [“Pumpdown failure shutdown”](#) on page 174. You must power cycle the MSD to recover from this state.
- Disconnected foreline pump power cord
- Malfunctioning foreline pump
- Check power switch on foreline pump

MSD turns on but then the foreline pump shuts off

MSDs will shut down both the foreline pump and the high vacuum pump if the system fails to pump down correctly. This is usually because of a large air leak: either the sideplate has not sealed correctly or the vent valve is still open. This feature helps prevent the foreline pump from sucking air through the system, which can damage the analyzer and pump.

See “[Pumpdown failure shutdown](#)” on page 174. You must power cycle the MSD to recover from this state.

Local control panel says “No server found”

- Disconnected LAN cable between MSD and the hub, or the hub and the PC
- PC is turned off
- Holding the No/Cancel key down for 5 seconds will bypass error and allow the user to look at the LCP.

Chromatographic Symptoms

These are symptoms you may observe in the chromatograms generated by data acquisition. In general, these symptoms do not prevent you from operating your GC/MSD system. They indicate, however, that the data you are acquiring may not be the best data obtainable. These symptoms can be caused by instrument malfunctions but are more likely caused by incorrect chromatographic technique.

Two of the symptoms: *If sensitivity is low* and *If repeatability is poor*, also apply to mass spectral data.

No peaks

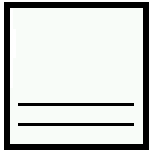

If an analysis shows no chromatographic peaks, only a flat baseline or minor noise, run one of the automated tune programs. If the MSD passes tune, the problem is most likely related to the GC. If the MSD does not pass tune, the problem is most likely in the MSD.

Passes tune

- Incorrect sample concentration
- No analytes present
- Syringe missing from the ALS or not installed correctly
- Injection accidentally made in split mode instead of splitless mode
- Empty or almost empty sample vial
- Dirty GC inlet
- Leaking GC inlet*
- Loose column nut at the GC inlet*

* These could cause a fault condition in the GC that would prevent the GC from operating.

Does not pass tune

- Calibration vial is empty
- Excessive foreline or analyzer chamber pressure
- Very dirty ion source

2 General Troubleshooting

- Calibration valve is not working correctly
- Bad signal cable connection
- Filament has failed or is not connected correctly
- Bad ion source wiring connection
- Bad detector wiring connection
- Failed electron multiplier horn

Peaks are tailing

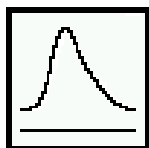

- Active sites in the sample path
- Injection is too large
- Incorrect GC inlet temperature
- Insufficient column flow
- GC/MSD interface temperature is too low
- Ion source temperature is too low

Peaks are fronting

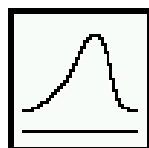

- Column film thickness mismatched with analyte concentration (column overload)
- Initial oven temperature is too low
- Active sites in the sample path
- Injection is too large
- GC inlet pressure too high
- Insufficient column flow

Peaks have flat tops

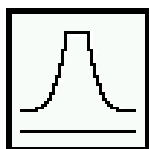

- Insufficient solvent delay
- Incorrect scale on the display
- Injection is too large
- Electron multiplier voltage is too high

Peaks have split tops

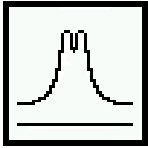

- Bad injection technique
- Injection is too large

Baseline is rising

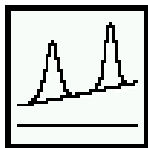

- Column bleed
- Other contamination

Baseline is high

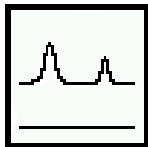

- Column bleed
- Other contamination
- Electron multiplier voltage is too high

Baseline is falling

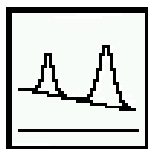

A falling baseline indicates contamination is being swept away. Wait until the baseline reaches an acceptable level. Common causes include:

- Residual water air and water from a recent venting
- Column bleed
- Septum bleed
- Splitless injection time too long (inlet is not properly swept, resulting in excess solvent on the column and slow solvent decay)

Baseline wanders

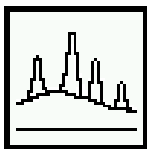

- Insufficient carrier gas supply pressure*
- Malfunctioning flow or pressure regulator*
- Intermittent leak in the GC inlet*

* These could cause a fault condition in the GC that would prevent the GC from operating.

Retention times for all peaks drift – shorter

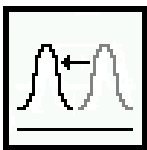

- Column has been shortened
- Initial oven temperature was increased
- Column is getting old

Retention times for all peaks drift – longer

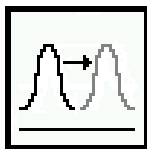

- Column flow has been reduced
- Initial oven temperature was decreased
- Active sites in the sample path
- Leaks in the GC inlet*

* This could cause a fault condition in the GC that would prevent the GC from operating.

Poor sensitivity

- Incorrect tuning
- Tune file that does not match the type of analysis
- Repeller voltage is too low
- Incorrect temperatures (oven, GC/MSD interface, ion source, or mass filter)
- Incorrect sample concentration
- Leaking GC inlet*
- Dirty GC inlet
- Incorrect split ratio
- Purge off time in splitless mode is too short
- Excessive pressure in the MSD
- Dirty ion source
- Air leak
- Poor filament operation
- Detector (HED electron multiplier) is not working correctly
- Incorrect mass filter polarity

* This could cause a fault condition in the GC that would prevent the GC from operating.

Poor repeatability

- Dirty syringe needle
- Dirty GC inlet
- Leaking GC inlet*
- Injection is too large
- Loose column connections
- Variations in pressure, column flow, and temperature
- Dirty ion source
- Loose connections in the analyzer
- Ground loops

* This could cause a fault condition in the GC that would prevent the GC from operating.

Mass Spectral Symptoms

This section describes symptoms you might observe in mass spectra. Some of these symptoms will appear in the mass spectra of samples. Others you will observe only in a tune report. Some of these symptoms have causes that can be corrected by the operator. Others, however, require service by an Agilent Technologies service representative.

Two symptoms listed under Chromatographic symptoms: *If sensitivity is poor* and *If repeatability is poor*, also apply to mass spectra.

No peaks

- Ion source cables not connected
- Bad connections to or from the detector
- HED power supply output cable has failed
- Other electronics failure

Isotopes are missing or isotope ratios are incorrect

- Peaks are too wide or too narrow
- Scan speed is too high (scan mode)
- Dwell time is too short (SIM mode)
- Electron multiplier voltage is too high
- Repeller voltage is too high
- High background
- Dirty ion source

High background

- Pressure in the analyzer chamber is too high
- Air leak
- Contamination

High abundances at m/z 18, 28, 32, and 44 or at m/z 14 and 16

- System was recently vented (residual air and water)
- Air leak. Large peaks at m/z 14 and 16 are symptomatic of especially large leaks.

Mass assignments are incorrect

Small shape changes at the top of the mass peaks can cause 0.1 m/z shifts in mass assignments. Shifts greater than 0.2 m/z indicate a possible malfunction.

- MSD has not had enough time to reach thermal equilibrium
- Large variations in the temperature of the laboratory
- MSD has not been tuned recently, or at the temperature at which it is operating
- Incorrect tune file (inappropriate parameters)

Peaks have precursors

The tune report lists the size of the precursors for the tune masses. Small precursors are not unusual. If the precursors are unacceptably large for your application, one of the following may be responsible:

- Repeller voltage is too high
- Peaks are too wide
- Incorrect DC polarity on the quadrupole mass filter
- Dirty quadrupole mass filter

Peak widths are inconsistent

- MSD has not had enough time to reach thermal equilibrium
- Large variations in the temperature of the laboratory
- Incorrect tuning
- Calibration vial(s) empty or almost empty
- Calibration valve(s) not working correctly
- Dirty ion source
- Electron multiplier is nearing the end of its useful lifetime
- Ground loop problems

Relative abundance of m/z 502 is less than 3%

Autotune should give an m/z 502 relative abundance greater than 3%. The relative abundance of m/z 502 can, however, vary a great deal depending on column flow, ion source temperature, and other variables. As long as relative abundance is above 3%, the stability of the relative abundance is more important than the absolute value. If you observe significant changes in the relative abundance of m/z 502 for a fixed set of operating parameters, there may be a problem. The charts in the MSD ChemStation software are useful for identifying changes. Select **View Tunes** from the Checkout menu in the Instrument Control view.

Low **relative** abundance of m/z 502 should not be confused with low **absolute** abundances at high masses. Sensitivity at high masses can be excellent even if the relative abundance of m/z 502 is near 3%. If your MSD produces low absolute abundances at high masses, refer to the symptom *High mass sensitivity is poor*.

Tune programs other than autotune have different relative abundance targets. The DF1TPP and BFB target tune programs tune the MSD to achieve about a 0.8% ratio of m/z 502/69.

- Tune program/tune file has a different relative abundance target (3% only applies to Autotune)
- Not enough time for the MSD to warm up and pump down
- Analyzer chamber pressure is too high
- Ion source temperature is too high
- Column (carrier gas) flow is too high
- Poor filament operation
- Dirty ion source
- Air leak
- Incorrect DC polarity on the quadrupole mass filter

Spectra look different from those acquired with other MSDs

Ion ratios are different from those in older models MSDs. This is due to the HED detector, and is normal. To get spectra similar to older MSDs, use **Standard Spectra Tune**, available in the Manual Tune view. Note that this tune takes much longer to complete than **Autotune**.

High mass sensitivity is poor

This refers to a condition where the **absolute** abundance at the upper end of the mass range is poor. Absolute abundance should not be confused with the **relative** abundance (percentage) of m/z 502 to m/z 69. Sensitivity at high masses can be excellent even if the relative abundance of m/z 502 is low.

- Wrong tune program
- Wrong tune file
- Repeller voltage is too low
- Not enough time for the MSD to warm up and pump down
- Analyzer chamber pressure is too high
- Column (carrier gas) flow is too high
- Poor filament operation
- Dirty ion source
- Air leak
- Incorrect DC polarity on the quadrupole mass filter

Pressure Symptoms

This section describes unusual pressure readings and their possible causes. The symptoms in this section are based on typical pressures. At typical column flow rates (0.1 to 2.0 mL/minute), the foreline pressure will be approximately 20 to 100 mTorr. The analyzer chamber pressure will be approximately 1×10^{-6} to 1.4×10^{-4} Torr. These pressures can vary widely from instrument to instrument so it is very important that you are familiar with the pressures that are typical for your instrument at given carrier gas flows. Also, foreline pressures can only be measured on diffusion pump MSDs.

Turbo pumps are controlled according to their speed and do not have foreline pressure gauges. The analyzer chamber pressures can only be measured if your system is equipped with the optional gauge controller.

Foreline pressure is too high

If the pressure you observe for a given column flow has increased over time, check the following:

- Column (carrier gas) flow is too high
- Air leak (usually the sideplate is not pushed in or vent valve is open)
- Foreline pump oil level is low or oil is contaminated (standard foreline pump)
- Foreline hose is constricted
- Foreline pump is not working correctly

Analyzer chamber pressure is too high (EI operation)

If the pressure you observe is above 1.0×10^{-4} Torr, or if the pressure you observe for a given column flow has increased over time, check the following:

- Column (carrier gas) flow is too high
- Air leak
- Foreline pump is not working correctly (see *Foreline pressure is too high*)
- Turbo pump is not working correctly
- Diffusion pump fluid level is low or fluid is contaminated

Foreline pressure is too low

If the pressures you observe are below 20 mTorr, check for the following:

- Column (carrier gas) flow is too low
- Column plugged or crushed by an overtightened nut
- Empty or insufficient carrier gas supply*
- Bent or pinched carrier gas tubing*
- Foreline gauge is not working correctly

* These could create a fault condition in the GC that would prevent the GC from operating.

Analyzer chamber pressure is too low

If the pressures you observe are below 1×10^{-6} Torr, check for the following:

- Column (carrier gas) flow is too low
- Column plugged or crushed by overtightened nut
- Empty or insufficient carrier gas supply*
- Bent or pinched carrier gas tubing*

* These could create a fault condition in the GC that would prevent the GC from operating.

Gauge controller displays 9.9+9 and then goes blank

This indicates the pressure in the analyzer chamber is above 8×10^{-3} Torr.

- Solvent peak from an on-column injection
- MSD has not had enough time to pump down
- Excessive foreline pressure
- Vacuum gauge has failed
- Line voltage too low
- Turbo pump is not working correctly
- Diffusion pump fluid level is low or fluid is contaminated

Power indicator on the gauge controller does not light

- Unplugged gauge controller power cord
- Incorrect or inadequate line voltage (24 V supply)
- Failed gauge controller fuse

Temperature Symptoms

The MSD has three heated zones:

- Ion source (**Source** in the MSD ChemStation software)
- Mass filter (**Quad** in the MSD ChemStation software)
- GC/MSD interface (in the MSD ChemStation software **Thermal Aux #2** for the Agilent 7890A and 6890, **Thermal Aux #1** for the Agilent 7820A, **Thermal Aux** for the Agilent 6850)

Each heated zone has a heater and temperature sensor. The ion source and mass filter are powered and controlled by the MSD. The GC/MSD interface is powered and controlled by the GC. For the 7820A Series GC's, the heater is either connected to the rear inlet thermal zone for the single inlet models or connected to the manual valve thermal zone for dual inlet models.

Ion source will not heat up

- High vacuum pump is off or has not reached normal operating conditions*
- Incorrect temperature setpoint
- Ion source has not had enough time to reach temperature setpoint
- Ion source heater cartridge is not connected*
- Ion source temperature sensor is not connected*
- Ion source heater failed (burned out or shorted to ground)*
- Ion source temperature sensor failed*
- Source power cable is not connected to the side board*
- MSD electronics are not working correctly

* These will cause an error message.

Mass filter (quad) heater will not heat up

- High vacuum pump is off or has not reached normal operating conditions*
- Incorrect temperature setpoint
- Mass filter has not had enough time to reach temperature setpoint
- Mass filter heater cartridge is not connected*
- Mass filter temperature sensor is not connected*

2 General Troubleshooting

- Mass filter heater failed (burned out or shorted to ground)*
- Mass filter temperature sensor failed*
- Source power cable is not connected to the sideboard*
- MSD electronics are not working correctly

* These will cause an error message.

GC/MSD interface will not heat up

- Incorrect setpoint(s)
- Setpoint entered in wrong heated zone
- GC/MSD interface has not had enough time to reach temperature setpoint
- GC is off
- GC experienced a fault and needs to be reset*
- GC/MSD interface heater/sensor cable is not connected*
- GC/MSD heater failed (burned out)*
- GC/MSD sensor failed*
- GC electronics are not working correctly*

* These will cause a GC error message. GC error messages are described in the documentation supplied with your GC.

Error Messages

Sometimes, a problem in your MSD will cause an error message to appear in the MSD ChemStation software. Some error messages appear only during tuning. Other messages may appear during tuning or data acquisition.

Some error messages are “latched.” These messages remain active in your data system even if the condition that caused the message has corrected itself. If the cause is removed, these messages can be removed by checking instrument status through the data system.

Difficulty in mass filter electronics

- Pressure in the analyzer chamber is too high
- RFPA is not adjusted correctly
- Mass filter (quad) contacts are shorted or otherwise not working correctly
- Mass filter is not working correctly
- MSD electronics are not working correctly

Difficulty with the electron multiplier supply

- Large peak, such as the solvent peak, eluted while the analyzer was on
- Pressure in the analyzer chamber is too high
- MSD electronics are not working correctly

Difficulty with the fan

If a cooling fan fault occurs, the vacuum control electronics automatically shut off the high vacuum pump and the ion source and mass filter heaters. Therefore, the message: *The system is in vent state* may also appear. It is important to note that even though the high vacuum pump is off, the analyzer chamber may not actually be vented. See *The system is in vent state* in this section for precautions to take.

- One of the fans is disconnected
- One of the fans has failed
- MSD electronics are not working correctly

Difficulty with the HED supply

The only time this error occurs is if the output of the supply cannot get to its destination (the HED).

- Large peak, such as the solvent peak, eluted while the analyzer was on
- Pressure in the analyzer chamber is too high
- Detector is not working correctly
- MSD electronics are not working correctly

Difficulty with the high vacuum pump

In an MSD equipped with a diffusion pump, this indicates the diffusion pump became too hot. In an MSD with a turbo pump, this indicates the pump failed to reach 50% of full speed within 7 minutes or experienced a fault.

You must switch the MSD off and back on to remove this error message. Be sure the diffusion pump has cooled or the turbo pump has slowed down before switching off the MSD. The message will reappear if the underlying problem has not been corrected.

Diffusion pump

- Air intakes to the cooling fan are blocked
- Laboratory temperature is too high (generally above 35 °C)
- High vacuum signal cable is disconnected or not working correctly
- Diffusion pump temperature sensor is not working correctly
- MSD electronics are not working correctly

Turbo pump

- Large vacuum leak is preventing the turbo pump from reaching 50% of full speed
- Foreline pump is not working correctly
- Turbo pump is not working correctly
- Turbo pump controller is not working correctly
- MSD electronics are not working correctly

High foreline pressure

- Excessive carrier gas flow (typically > 5 mL/min)
- Excessive solvent volume injected
- Large vacuum leak
- Severely degraded foreline pump oil (standard foreline pump)
- Collapsed or kinked foreline hose
- Foreline pump is not working correctly
- Foreline gauge is not working correctly (diffusion pump MSD only)

Internal MS communication fault

- MSD electronics are not working correctly

Lens supply fault

- Electrical short in the analyzer
- MSD electronics are not working correctly

Log amplifier ADC error

- MSD electronics are not working correctly

No peaks found

- Emission current was set to 0
- Electron multiplier voltage is too low
- Amu gain or offset is too high
- Poor mass axis calibration
- Amu gain or offset is too high
- Calibration vial(s) empty or almost empty
- Excessive pressure in the analyzer chamber
- Air leak
- Electron multiplier voltage is too low
- Signal cable is not connected

- Electrical leads to the detector are not connected correctly
- HED power supply output cable failed
- Electrical leads to the ion source are not connected correctly
- Filament shorted to the source body

Temperature control disabled

- One of the heater fuses has failed
- MSD electronics are not working correctly

Temperature control fault

This indicates that something has gone wrong with the temperature control of either the ion source or mass filter (quad) heater. The cause can be further isolated by selecting **Status/MS Temp Ctlr Status** in the Tune and Vacuum Control view. One of the following should be displayed as the cause:

- Source temperature sensor is open
- Source temperature sensor is shorted
- Mass filter (quad) temperature sensor is open
- Mass filter (quad) temperature sensor is shorted
- No heater voltage (heater fuse has probably failed)
- Heater voltage is too low
- Temperature zone has timed out (heater failed, bad heater wiring, or loose temperature sensor)
- Problem with the temperature control electronics
- Source heater is open
- Source heater is shorted
- Mass filter heater is open
- Mass filter heater is shorted

The high vacuum pump is not ready

- Diffusion pump is on but has not had enough time (10-15 minutes) to reach its normal operating temperature
- Turbo pump is on but has not had enough time (5 minutes) to reach 80% of its normal operating speed
- Level of fluid in the diffusion pump is too high
- Diffusion pump stack is not aligned correctly
- Turbo pump is not working correctly
- MSD electronics are not working correctly

The system is in standby

This message is triggered by a shutdown signal on the remote start cable. It is usually caused by a GC fault, an ALS fault, or a bad cable connection. Once the cause of the fault is corrected, selecting **MS ON** or checking MSD status should remove the message.

The system is in vent state

The message says the system is vented, but if the fault has just occurred it may still be under vacuum and the diffusion pump may still be hot or the turbo pump may still be at high speed. Wait at least 30 minutes after seeing this message before you actually vent the MSD.

CAUTION

Venting the MSD too soon after this message appears can damage a turbo pump.

-
- System was vented on purpose (no problem)
 - Fan fault has turned off the high vacuum pump (power cycle the MSD to clear the fault)
 - Fuse for the high vacuum pump has failed
 - Diffusion pump heater cartridge has failed
 - MSD electronics are not working correctly

There is no emission current

- Filament is not connected properly; try the other filament
- Filament has failed; try the other filament
- MSD electronics are not working correctly

There is not enough signal to begin tune

- Corrupted tune file
- Poor mass axis calibration
- Amu gain or offset is too high
- Calibration vial(s) empty or almost empty
- Excessive pressure in the analyzer chamber
- Air leak
- Electron multiplier voltage is too low
- Signal cable is not connected
- Electrical leads to the detector are not connected correctly
- Electrical leads to the ion source are not connected correctly
- Filament shorted to the source body

Air Leaks

Air leaks are a problem for any instrument that requires a vacuum to operate. Leaks are generally caused by vacuum seals that are damaged or not fastened correctly. Symptoms of leaks include:

- Higher than normal analyzer chamber pressure or foreline pressure
- Higher than normal background
- Peaks characteristic of air (m/z 18, 28, 32, and 44 or m/z 14 and 16)
- Poor sensitivity
- Low relative abundance of m/z 502 (this varies with the tune program used)

Leaks can occur in either the GC or the MSD. The most likely point for an air leak is a seal you recently opened.

In the GC, most leaks occur in:

- GC inlet septum
- GC inlet column nut
- Broken or cracked capillary column

Leaks can occur in many more places in the MSD:

- GC/MSD interface column nut
- Side plate O-ring (all the way around)
- Vent valve O-ring
- Calibration valve(s)
- GC/MSD interface O-ring (where the interface attaches to the analyzer chamber)
- Front and rear end plate O-rings
- Diffusion pump KF seal
- Diffusion pump baffle adapter O-ring
- Turbo pump O-ring

Contamination

Contamination is usually identified by excessive background in the mass spectra. It can come from the GC or from the MSD. The source of the contamination can sometimes be determined by identifying the contaminants. Some contaminants are much more likely to originate in the GC. Others are more likely to originate in the MSD.

Contamination originating in the GC typically comes from one of these sources:

- Column or septum bleed
- Dirty GC inlet
- GC inlet liner
- Contaminated syringe
- Poor quality carrier gas
- Dirty carrier gas tubing
- Fingerprints (improper handling of clean parts)

Contamination originating in the MSD typically comes from one of the following sources:

- Air leak
- Cleaning solvents and materials
- Diffusion pump fluid
- Foreline pump oil (standard foreline pump)
- Fingerprints (improper handling of clean parts)

[Table 5](#) lists some of the more common contaminants, the ions characteristic of those contaminants, and the likely sources of those contaminants.

Table 5 Common contaminants

Ions (<i>m/z</i>)	Compound	Possible source
18, 28, 32, 44 or 14, 16	H ₂ O, N ₂ , O ₂ , CO ₂ or N, O	Residual air and water, air leaks, outgassing from Vespel ferrules
31, 51, 69, 100, 119, 131, 169, 181, 214, 219, 264, 376, 414, 426, 464, 502, 576, 614	PFTBA and related ions	PFTBA (tuning compound)
31	Methanol	Cleaning solvent
43, 58	Acetone	Cleaning solvent
78	Benzene	Cleaning solvent
91, 92	Toluene or xylene	Cleaning solvent
105, 106	Xylene	Cleaning solvent
151, 153	Trichloroethane	Cleaning solvent
69	Foreline pump oil or PFTBA	Foreline pump oil vapor or calibration valve leak
73, 147, 207, 221, 281, 295, 355, 429	Dimethylpolysiloxane	Septum bleed or methyl silicone column bleed
77, 94, 115, 141, 168, 170, 262, 354, 446	Diffusion pump fluid and related ions	Diffusion pump fluid
149	Plasticizer (phthalates)	Vacuum seals (O-rings) damaged by high temperatures, vinyl gloves
Peaks spaced 14 <i>m/z</i> apart	Hydrocarbons	Fingerprints, foreline pump oil

2 General Troubleshooting

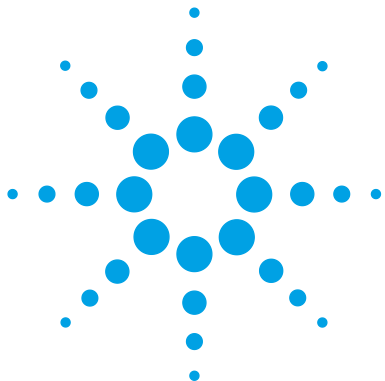

3 CI Troubleshooting

Common CI-Specific Problems	58
Troubleshooting Tips and Tricks	59
Air Leaks	60
Pressure-Related Symptoms	64
Signal-Related Symptoms	68
Tuning-Related Symptoms	77

This chapter outlines the troubleshooting of 5975 Series MSDs equipped with the chemical ionization (CI) source. Most of the troubleshooting information in the previous chapter also applies to CI MSDs.



Common CI-Specific Problems

Because of the added complexity of the parts required for CI, there are many potential problems added. By far the greatest number and most serious problems with CI are associated with leaks or contamination in the reagent gas introduction system. NCI is especially sensitive to the presence of air; leaks small enough to cause no problems in PCI can destroy NCI sensitivity.

As with EI, if the MSD tunes well and no air leak is present, sample sensitivity problems should be addressed by GC inlet maintenance first.

- Wrong reagent gas
- Reagent gas not hooked up or hooked up to wrong reagent gas inlet port
- Wrong ions entered in tune file
- Wrong tune file selected
- Not enough bakeout time has elapsed since vent (background is too high)
- Wrong column positioning (extending > 2 mm past tip of interface)
- Interface tip seal not installed
- EI source installed in CI mode
- EI filament or other EI source parts in CI ion source
- Air leaks in reagent gas flow path
- CI filament has stretched and sagged:
 - High EMV
 - Linear (no inflection point) electron energy (EIEnrgy) ramp

Troubleshooting Tips and Tricks

Rule 1: “Look for what has been changed.”

Many problems are introduced accidentally by human actions. Every time any system is disturbed, there is a chance of introducing a new problem.

- If the MSD was just pumped down after maintenance, suspect air leaks or incorrect assembly.
- If the reagent gas bottle or gas purifier were just changed, suspect leaks or contaminated or incorrect gas.
- If the GC column was just replaced, suspect air leaks or contaminated or bleeding column.
- If you have just switched ion polarity or reagent gas, suspect the tune file you have loaded in memory. Is it the appropriate file for your mode of operation?

Rule 2: “If complex isn’t working, go back to simple.”

A complex task is not only more difficult to perform, but also more difficult to troubleshoot as well. For example, CI requires more parts to work correctly than EI does.

- If you’re having trouble with NCI, verify that PCI still works.
- If you’re having trouble with other reagent gases, verify that methane still works.
- If you’re having trouble with CI, verify that EI still works.

Rule 3: “Divide and conquer.”

This technique is known as “half-split” troubleshooting. If you can isolate the problem to only part of the system, it is much easier to locate.

- To isolate an air leak, select **Shutoff valve**. If abundance of m/z 32 decreases, the problem is not in the flow module.

Air Leaks

How do I know if I have an air leak?

Large air leaks can be detected by vacuum symptoms: loud gurgling noise from the foreline pump, inability of the turbo pump to reach 95% speed, or, in the case of smaller leaks, high pressure readings on the high vacuum gauge controller.

The mass flow controller is calibrated for methane and the high vacuum gauge controller is calibrated for nitrogen, so measurements are not accurate in absolute terms:

Familiarize yourself with the measurements on **your** system under operating conditions. Watch for **changes** that may indicate a vacuum or gas flow problem.

Always look for small air leaks when setting up methane flow. Run the **methane** pretune, starting with a good PCI tune file (Figure 2). The abundance of m/z 19 (protonated water) should be less than 50% of m/z 17 for acceptable PCI performance. For NCI, the abundance of m/z 19 (protonated water) should be less than 25% that of m/z 17. If the MSD was just pumped down, look for the abundance of m/z 19 to be decreasing.

There should not be any peak visible at m/z 32 (O_2). This almost always indicates an air leak.

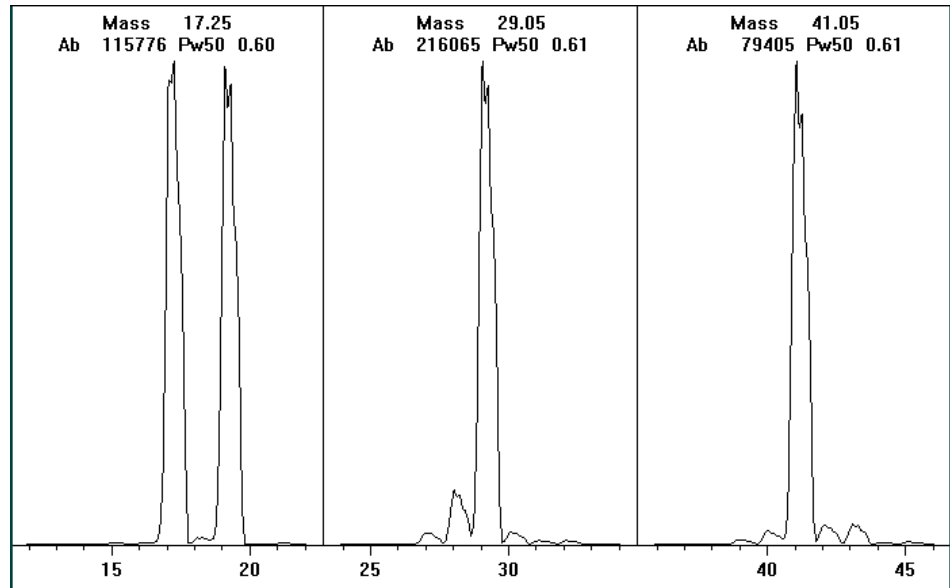

Figure 2 Looking for air leaks

Special NCI notes

Since NCI is so extremely sensitive, air leaks that are not detectable in EI or PCI can cause sensitivity problems in NCI. To check for this kind of air leak in NCI, inject OFN. The base peak should be at m/z 272. If the abundance of m/z 238 is much greater than that of m/z 272, you have an air leak.

How do I find the air leak?

- 1 See [Figure 3](#) and [Table 6](#).
- 2 Look for the last seal that was disturbed.
 - If you just pumped down the MSD, press on the sideplate to check for proper seal. Poor alignment between the analyzer and the GC/MSD interface seal can prevent the sideplate from sealing.

3 CI Troubleshooting

- If you just replaced the reagent gas bottle or gas purifier, check the fittings you just opened and refastened.
- 3 Check for tightness of seals at GC inlet and interface column nuts. Ferrules for capillary columns often loosen after several heat cycles. Do not overtighten the interface nut.
 - 4 If any of the fittings *inside* the flow module (VCR fittings) were loosened and then retightened, the gasket must be replaced. These gaskets are good for one use only.

CAUTION

Do not loosen the nuts on any VCR fittings unless you intend to replace the gaskets. Otherwise, you will create an air leak.

- 5 Remember that most small air leaks visible in CI mode are located in either the carrier gas or reagent gas flow paths. Leaks into the analyzer chamber are not likely to be seen in CI because of the higher pressure inside the ionization chamber.
- 6 Half-split the system.
 - Close valves starting at the gas select valves (**Gas A** , then **Gas B**), then close the shutoff valve. See [Figure 3](#) and [Table 6](#).
 - Cool and vent the MSD, remove the GC column, and cap off the interface.

If you use argon or other introduced gas to find air leaks, this does not work well for the reagent gas flow system. It takes as long as 15 minutes for the peak to reach the ion source if the leak is at the inlet to the flow module.

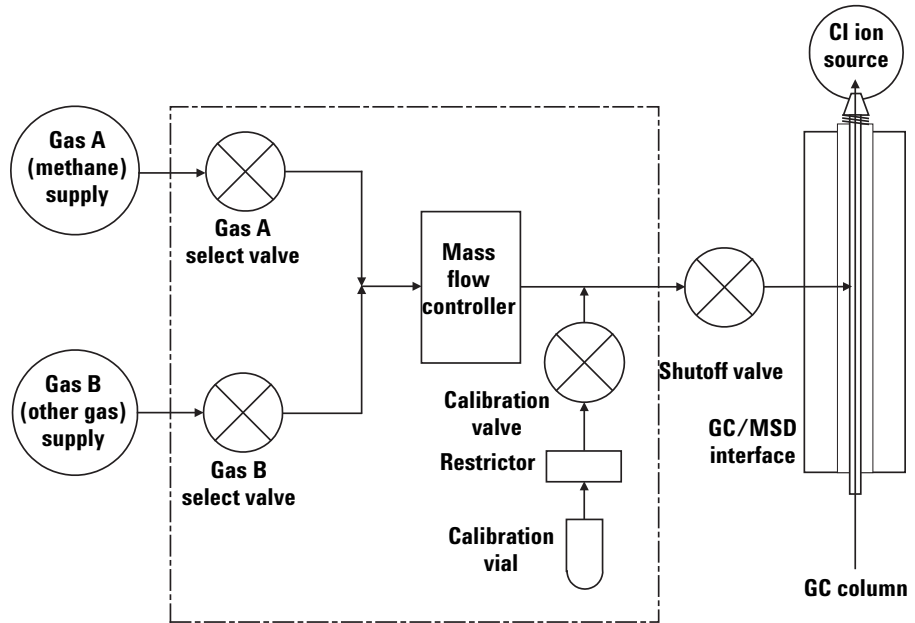

Figure 3 Schematic of CI flow control module

Table 6 Flow module valve state diagram

Result	Gas A flow	Gas B flow	Purge with Gas A	Purge with Gas B	Pump out flow module	Standby, vented, or EI mode
Gas A	Open	Closed	Open	Closed	Closed	Closed
Gas B	Closed	Open	Closed	Open	Closed	Closed
MFC	On (at setpoint)	On (at setpoint)	On (at 100%)	On (at 100%)	On (at 100%)	Off (at 0%)
Shutoff valve	Open	Open	Open	Open	Open	Closed

Pressure-Related Symptoms

The following symptoms are all related to high vacuum pressure. Each symptom is discussed in more detail in the following pages.

The mass flow controller is calibrated for methane and the high vacuum gauge controller is calibrated for nitrogen, so these measurements are not accurate in absolute terms (Table 7). They are intended as a guide to typical observed readings. They were taken with the following set of conditions:

Source temperature	250 °C
Quad temperature	150 °C
Interface temperature	280 °C
Helium carrier gas flow	1 mL/min

Table 7 Pressure measurements

MFC (%)	Pressure (Torr)	
	Methane	Ammonia
	Performance turbo pump	Performance turbo pump
10	5.5×10^{-5}	5.0×10^{-5}
15	8.0×10^{-5}	7.0×10^{-5}
20	1.0×10^{-4}	8.5×10^{-5}
25	1.2×10^{-4}	1.0×10^{-4}
30	1.5×10^{-4}	1.2×10^{-4}
35	2.0×10^{-4}	1.5×10^{-4}
40	2.5×10^{-4}	2.0×10^{-4}

Poor vacuum without reagent gas flow

Excess water in the background

Scan from 10 to 40 m/z . A large peak at m/z 19 ($>m/z$ 17) indicates water in the background. If water is present, allow the instrument to bake out more and flow reagent gas through the lines to purge any accumulated water.

Air leak

Run Methane Pretune. See the *Operation Manual*. A visible peak at m/z 32 indicates air in the system. Check for and correct any leaks. See the *Leaks* section at the beginning of this chapter.

The foreline pump is not working properly

For the standard foreline pump, replace the pump oil. If that does not help, or for the dry foreline pump, it may be necessary to replace the pump. Contact your local Agilent Technologies Customer Engineer.

The turbo pump is not working properly

Check the pump speed. It should be at least 95%. Contact your local Agilent Technologies service representative.

CAUTION

Use of ammonia as reagent gas can shorten the life of the foreline pump oil (with standard pump) and possibly of the foreline pump itself. See [“To Minimize Foreline Pump Damage from Ammonia \(Standard Pump\)”](#) on page 166.

High pressure with reagent gas flow

The reagent gas flow rate is too high

On the flow controller, turn down reagent gas flow as appropriate. Verify that reagent ion ratios are correct.

Air leak

Run Methane Pretune. See the *Operation Manual*. Visible peak at m/z 32 indicates air in the system. Check for and correct any leaks. See the *Leaks* section at the beginning of this chapter.

Interface tip seal is not installed

Check the source storage box. If the seal is not in the box, vent the MSD and verify that the seal is correctly installed.

Pressure does not change when reagent flow is changed

The reagent gas regulator is closed

Check and, if necessary, open the reagent gas regulator.

The reagent gas regulator is set to the wrong pressure

Set the reagent gas regulator to 10 psi (70 kPa) for methane or to 3 to 10 psi (20 to 70 kPa) for isobutane or ammonia.

The valve on the reagent gas bottle is closed

Check and, if necessary, open the valve on the reagent gas bottle.

The reagent gas supply is empty

Check and, if necessary, replace the reagent gas supply.

Reagent lines kinked, bent, pinched, or disconnected

Inspect the reagent lines and repair any defects. Check especially to make sure the reagent line is connected to the rear of the flow module. Be sure the methane line is connected to the Gas A inlet.

GC/MSD interface clogged or damaged

Check for flow and repair or replace components as indicated.

Signal-Related Symptoms

This section describes symptoms related to the signal. The symptom may be too much signal, too little signal, a noisy signal, or an incorrect signal. Signal-related symptoms are generally observed during tuning but may also be observed during data acquisition.

Error messages in autotune due to insufficient signal may vary.

The following symptoms are covered in more detail in this section:

- No peaks. See [page 69](#).
- No or low reagent gas signal. See [page 71](#).
- No or low PFDTD signal. See [page 73](#).
- Excessive noise. See [page 74](#).
- Low signal-to-noise ratio. See [page 74](#).
- Large peak at m/z 19. See [page 75](#).
- Peak at m/z 32. See [page 76](#).

No peaks

When troubleshooting “no peaks” it is important to specify what mode of operation is being used and what expected peaks are not being seen. Always start with methane PCI and verify presence of reagent ions.

No reagent gas peaks in PCI

If MSD has been working well and nothing seems to have been changed

- Wrong tune file loaded, or tune file corrupted
- Wrong ion polarity (there are no reagent ions visible in NCI)
- No reagent gas flow; look for background ions and check pressure
- Wrong reagent gas selected for the tune file (looking for wrong ions)
- Large air leak
- Dirty ion source
- Poor vacuum (pump problem). See [page 64](#).

If MSD was recently switched from EI to CI

- Interface tip seal not installed
- No reagent gas flow
- Analyzer not sealed (big air leak)
- Wrong tune file loaded or tune file corrupted
- Ion source not assembled or connected correctly
- Wrong reagent gas selected for the tune file (looking for wrong ions)

No PFDTD peaks in PCI

- Incorrect reagent gas. There **are** no PCI PFDTD peaks created with isobutane or ammonia. Switch to methane.
- Analyzer not sealed (big air leak)
- No calibrant in vial
- Defective calibration valve(s)
- Air leak in carrier or reagent gas path

No reagent gas peaks in NCI

- Reagent gases do not ionize in NCI; look for background ions instead
- Verify tune parameters
- If no background ions are visible, go back to methane PCI

No PFDTD calibrant peaks in NCI

- Look for background ions: 17 (OH^-), 35 (Cl^-), and 235 (ReO_3^-)
- Verify tune parameters
- Go back to methane PCI

No sample peaks in NCI

- Look for background ions: 17 (OH^-), 35 (Cl^-), and 235 (ReO_3^-)
- Go back to methane PCI
- Poor quality reagent gas (purity less than 99.99%)

Large peak at m/z 238 in NCI OFN spectrum

- Look for background ions: 17 (OH^-), 35 (Cl^-), and 235 (ReO_3^-)
- Find and fix your small air leak

No or low reagent gas signal

If you have just installed the CI ion source and have an air leak or large amounts of water in the system and have run one or more autotunes, the ion source is probably dirty now.

Fix the air leak. Clean the ion source. Then bake out for two hours before tuning. See the *Operation Manual*.

The wrong reagent gas is flowing.

Turn on the correct reagent gas for your tune file.

Ion polarity is set to Negative. No reagent gas ions are formed in NCI.

Switch to Positive ionization mode.

The reagent gas flow is set too low.

Increase the reagent gas flow.

Reagent gas supply tubing is blocked, kinked, pinched, or disconnected.

Inspect and, if necessary, repair or replace the reagent gas supply tubing.

Wrong filament wires are connected to filament.

Make sure that the filament 1 wires are connected to the CI ion source filament and that the filament 2 wires are connected to the dummy filament.

Carbon has built up on the filament or filament has sagged out of alignment.

Inspect the filament. If necessary, replace the filament.

Too much air or water in the system.

Run the methane pretune. Peaks at m/z 32 and 19 usually indicate air and water, respectively. Bake out and purge the instrument until there is no visible peak at m/z 32 and the peak at m/z 19 is reduced to a very low level. If the peak at m/z 32 does not decrease, an air leak is likely. See “Air Leaks” on page 60 for more information.

The signal cable is not connected.

Check and, if necessary, reconnect the signal cable.

The filament or filament support is shorted to the ion source body or repeller.

Inspect the filament. If necessary, realign the filament support arms.

The electron inlet hole is blocked.

Inspect the electron inlet hole. If necessary, clean the hole with a clean toothpick and a slurry of aluminum oxide powder and methanol. If the electron inlet hole is that dirty, the entire ion source probably needs to be cleaned. See [“General Maintenance”](#) on page 83 for more information.

Ion source wires are not connected, or incorrectly connected.

Inspect the repeller. Make sure the repeller lead is firmly attached to the repeller. Inspect the wires to the ion focus and entrance lenses. If the connections are reversed, correct the problem.

One of the detector leads (in the analyzer chamber) is not connected.

Check and, if necessary, reconnect the electron multiplier leads.

Saturated methane/isobutane gas purifier

Replace the gas purifier.

Poor quality methane (purity below 99.99%)

Replace the methane with high-purity methane. If necessary, clean and purge the reagent gas lines and clean the ion source.

No or low PFDTD signal, but reagent ions are normal

You are using any reagent gas but methane in PCI.

Switch to methane.

Wrong or corrupted tune file loaded

Check your tune file.

No PFDTD in the calibrant vial

Inspect the calibration vial on the back of the flow controller. If necessary, fill the vial with PFDTD. Do not fill the vial completely; keep the level at least 0.5 cm from the top of the vial.

The pressure of the methane entering the flow controller is too high.

Make sure the regulator on the methane supply is set to 10 psig (70 kPa).

The CI ion source is dirty.

Clean the ion source. See [“CI Maintenance”](#) on page 163 for more information.

The calibration valve was not purged after the vial was refilled.

Purge the calibration valve as described in [“To Purge the Calibration Valves”](#) on page 111. Then clean the ion source.

The calibrant vial was overfilled. Excess PFDTD can quench the chemical ionization reactions.

Check the level of the PFDTD in the calibration vial. It should be *below* the end of the inside tube in the vial.

Poor quality methane (purity below 99.99%)

Replace the methane with high-purity methane. If necessary, clean and purge the reagent gas lines and clean the ion source.

Excessive noise or low signal-to-noise ratio

The GC inlet needs maintenance.

Refer to the GC manual.

The CI ion source is dirty.

Clean the ion source. See “To Clean the CI Ion Source” on page 164 for more information.

Poor vacuum

Check the pressure on the high vacuum gauge controller.

Air leak

Run Methane Pretune (in PCI). Large peak at m/z 32 indicates air in the system. Check for and correct any leaks. See the *Leaks* section at the beginning of this chapter.

Saturated methane/isobutane gas purifier

Replace the gas purifier.

Poor quality methane (purity below 99.99%)

Replace the methane with high-purity methane. If necessary, clean and purge the reagent gas lines and clean the ion source.

Reagent gas flows too high (in EI/PCI MSDs)

Verify that the reagent gas setup is correct.

Large peak at m/z 19

If the abundance of the peak at m/z 19 is more than half abundance of the peak at m/z 17, then there is probably too much water in the system.

The system was not baked out sufficiently after it was last vented.

Bake out the system as described in the *Maintenance* chapter of this manual.

Moisture left over in the reagent gas supply tubing and flow module

Purge the reagent gas supply lines for at least 60 minutes.

Contaminated reagent gas supply

Replace the reagent gas supply and purge the lines and flow module.

Saturated methane/isobutane gas purifier

Replace the gas purifier.

Peak at m/z 32

A visible peak at m/z 32 in methane pretune often indicates air in the system.

Residual air from recent venting — check for water indicated by a large peak at m/z 19.

Bake out the system under vacuum to eliminate water.

New or dirty reagent gas supply tubing

Purge the reagent gas supply lines and flow module *for at least 60 minutes*. See the *Operation Manual*.

Air leak

Check for leaks and correct any that you find. See “Air Leaks” on page 60. After all leaks have been corrected, clean the ion source.

Contaminated reagent gas supply. Suspect this if you have recently replaced your gas tank, and you have ruled out air leaks.

Replace the reagent gas supply.

The capillary column is broken or disconnected.

Inspect the capillary column. Make sure it is not broken and it is installed correctly.

Saturated methane/isobutane gas purifier

Replace the gas purifier.

Tuning-Related Symptoms

This section describes symptoms related to tuning. Most symptoms involve difficulties with tuning or with the results of tuning. The following symptoms are covered in this section:

- CI ion ratio is difficult to adjust or unstable
- High electron multiplier voltage
- Cannot complete autotune
- Peak widths are unstable

Reagent gas ion ratio is difficult to adjust or unstable

The interface tip seal is incorrectly placed, damaged, or missing.

Inspect the interface tip seal. If necessary, remove and reinstall it to ensure a good seal with the CI ion source. Replace it if it is damaged. Install it if it is missing.

Residual air and water in the MSD or in the reagent gas supply lines

Run the methane pretune. Air will appear as a peak at m/z 32 and excessive water as a peak at m/z 19 > m/z 17. If either of these conditions is present, purge the reagent gas supply lines and bake out the MSD. See [page 168](#). Continued presence of a large peak at m/z 32 may indicate an air leak. After correcting the problems, you may need to clean the ion source.

Air leak

Run Methane Pretune (in PCI). Large peak at m/z 32 indicates air in the system. Check for and correct any leaks. See “[Air Leaks](#)” on page 60.

The reagent gas supply is at the wrong pressure.

Check the regulator on the reagent gas supply. It should be adjusted to 20 psi (140 kPa).

A leak in the reagent gas delivery path. This is especially likely if you have set the methane flow much higher than normal and the ratio is still too low.

Check the reagent gas path. Tighten fittings.

The CI ion source is dirty.

Clean the ion source. See “[To Clean the CI Ion Source](#)” on page 164 for more information.

High electron multiplier voltage

The electron multiplier voltage can range from a few hundred volts to 3000 V. If the CI autotune program consistently sets the electron multiplier voltage at or above 2600 V but can still find peaks and complete the tune, it may indicate a problem.

The filament is worn out.

The CI filament may wear out without actually breaking. Check the Electron Energy ramp; the curve should have a definite maximum with an inflection point. If the curve is linear with a positive slope and no inflection point, and the EMV is high, the filament has stretched to the point where it does not line up with the hole in the ion source body, and most electrons are not getting into the source.

Replace the filament.

The analyzer is not at the proper operating temperature.

Verify the ion source and quadrupole temperatures. The default source temperature is 250 °C for PCI and 150 °C for NCI. The quadrupole temperature is 150 °C for both CI modes.

The CI ion source is dirty.

Clean the ion source. See “To Clean the CI Ion Source” on page 164 for more information.

The electron multiplier (detector) is failing. Switch to EI mode and confirm.

Replace the electron multiplier.

Cannot complete Autotune

Wrong or corrupted tune file

Check the tune parameters.

The m/z 28/27 ion ratio (for methane) is incorrect. The correct ratio should be between 1.5 and 5.0.

If the ion ratio is incorrect, adjust it. See the *Operation Manual*.

The CI ion source is dirty.

Clean the ion source. See “[To Clean the CI Ion Source](#)” on page 164 for more information.

Too much air or water in the system

See “[Air Leaks](#)” on page 60. After eliminating these problems, clean the ion source.

Peak widths are unstable

Wrong or corrupted tune file

Check the tune parameters.

The CI ion source is dirty.

Clean the ion source. See the “[CI Maintenance](#)” chapter of this manual for more information.

Air leak

Run Methane Pretune (in PCI). A visible peak at m/z 32 indicates air in the system. Check for and correct any leaks. See the “[Air Leaks](#)” section at the beginning of this chapter. After eliminating all air leaks, clean the ion source.

3 CI Troubleshooting

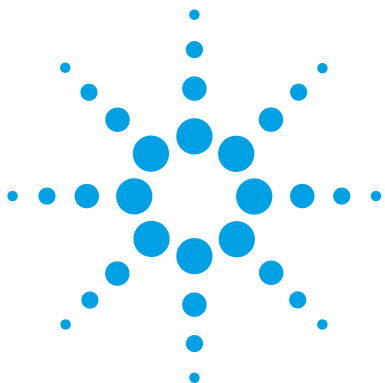

4 General Maintenance

Before Starting	84
Maintaining the Vacuum System	89
To Remove the MSD Covers	90
To Connect the Micro-Ion Vacuum Gauge	92
To Move or Store the MSD	94
To Check and Add Foreline Pump Oil	96
To Drain the Foreline Pump	98
To Refill the Foreline Pump	100
To Check the Diffusion Pump Fluid	101
To Separate the MSD from the GC	103
To Reconnect the MSD to the 7890A GC/7820A/6890 GC	105
To Reconnect the MSD to the 6850 GC	106
To Refill the EI Calibration Vial	109
To Purge the Calibration Valves	111
To Remove the EI Calibration and Vent Valve Assembly	112
To Reinstall the EI Calibration and Vent Valve Assembly	113
To Replace the Fan for the High Vacuum Pump	114
To Remove the Micro-Ion Vacuum Gauge	116
To Reinstall a Micro-Ion Vacuum Gauge	117
To Lubricate the Side Plate O-Ring	118
To Lubricate the Vent Valve O-Ring	120
To Remove the Diffusion Pump	122
To Replace the Diffusion Pump Fluid	124
To Reinstall the Diffusion Pump	127
To Remove the Foreline Gauge	129
To Reinstall the Foreline Gauge	130
Maintaining the Analyzer	131
Maintaining the GC/MSD Interface	153
Maintaining the Electronics	157



Before Starting

For your safety, read all of the information in this introduction before performing any maintenance tasks.

Scheduled maintenance

Common maintenance tasks are listed in [Table 8](#). Performing these tasks when scheduled can reduce operating problems, prolong system life, and reduce overall operating costs.

Keep a record of system performance (tune reports) and maintenance operations performed. This makes it easier to identify variations from normal operation and to take corrective action.

Table 8 Maintenance schedule

Task	Every week	Every 6 months	Every year	As needed
Tune the MSD				X
Check the foreline pump oil level	X			
Check the calibration vial(s)		X		
Replace the foreline pump oil*		X		
Replace the diffusion pump fluid			X	
Check the dry foreline pump diaphragms				X
Clean the ion source				X
Check the carrier gas trap(s) on the GC and MSD				X
Replace the worn out parts				X
Lubricate sideplate or vent valve O-rings†				X
Replace CI Reagent gas supply				X
Replace GC gas supplies				X

* Every 3 months for CI MSDs using ammonia reagent gas.

† Vacuum seals other than the side plate O-ring and vent valve O-ring do not need to be lubricated. Lubricating other seals can interfere with their correct function.

Tools, spare parts, and supplies

Some of the required tools, spare parts, and supplies are included in the GC shipping kit, MSD shipping kit, or MSD tool kit. You must supply others yourself. Each maintenance procedure includes a list of the materials required for that procedure. “Consumables and Maintenance Supplies” on page 260 summarizes these.

High voltage precautions

Whenever the MSD is plugged in, even if the power switch is off, potentially dangerous voltage (120 VAC or 200/240 VAC) exists on:

- The wiring and fuses between where the power cord enters the instrument and the power switch

When the power switch is on, potentially dangerous voltages exist on:

- Electronic circuit boards
- Toroidal transformer
- Wires and cables between these boards
- Wires and cables between these boards and the connectors on the back panel of the MSD
- Some connectors on the back panel (for example, the foreline power receptacle)

Normally, all of these parts are shielded by safety covers. As long as the safety covers are in place, it should be difficult to accidentally make contact with dangerous voltages.

WARNING

Perform no maintenance with the MSD turned on or plugged into its power source unless you are instructed to by one of the procedures in this chapter.

Some procedures in this chapter require access to the inside of the MSD while the power switch is on. Do not remove any of the electronics safety covers in any of these procedures. To reduce the risk of electric shock, follow the procedures carefully.

Dangerous temperatures

Many parts in the MSD operate at, or reach, temperatures high enough to cause serious burns. These parts include, but are not limited to:

- GC/MSD interface
- Analyzer parts
- Vacuum pumps

WARNING

Never touch these parts while your MSD is on. After the MSD is turned off, give these parts enough time to cool before handling them.

WARNING

The GC/MSD interface heater is powered by a heated zone on the GC. The interface heater can be on, and at a dangerously high temperature, even though the MSD is off. The GC/MSD interface is well insulated. Even after it is turned off, it cools very slowly.

WARNING

The foreline pump can cause burns if touched when operating. It has a safety shield to prevent the user from touching it.

The GC inlets and GC oven also operate at very high temperatures. Use the same caution around these parts. See the documentation supplied with your GC for more information.

Chemical residue

Only a small portion of your sample is ionized by the ion source. The majority of any sample passes through the ion source without being ionized. It is pumped away by the vacuum system. As a result, the exhaust from the foreline pump will contain traces of the carrier gas and your samples. Exhaust from the standard foreline pump also contains tiny droplets of foreline pump oil.

An oil trap is supplied with the standard foreline pump. This trap stops *only* pump oil droplets. It *does not* trap any other chemicals. If you are using toxic solvents or analyzing toxic chemicals, do not use this oil trap. For all foreline pumps, install a hose to take the exhaust from the foreline pump outdoors or

into a fume hood vented to the outdoors. For the standard foreline pump, this requires removing the oil trap. Be sure to comply with your local air quality regulations.

WARNING

The oil trap supplied with the standard foreline pump stops only foreline pump oil. It does not trap or filter out toxic chemicals. If you are using toxic solvents or analyzing toxic chemicals, remove the oil trap. Do not use the trap if you have a CI MSD. Install a hose to take the foreline pump exhaust outside or to a fume hood.

The fluids in the diffusion pump and standard foreline pump also collect traces of the samples being analyzed. All used pump fluid should be considered hazardous and handled accordingly. Dispose of used fluid correctly, as specified by your local regulations.

WARNING

When replacing pump fluid, use appropriate chemical-resistant gloves and safety glasses. Avoid all contact with the fluid.

Electrostatic discharge

All of the printed circuit boards in the MSD contain components that can be damaged by electrostatic discharge (ESD). Do not handle or touch these boards unless absolutely necessary. In addition, wires, contacts, and cables can conduct ESD to the electronics boards to which they are connected. This is especially true of the mass filter (quadrupole) contact wires which can carry ESD to sensitive components on the side board. ESD damage may not cause immediate failure but it will gradually degrade the performance and stability of your MSD.

When you work on or near printed circuit boards or when you work on components with wires, contacts, or cables connected to printed circuit boards, always use a grounded antistatic wrist strap and take other antistatic precautions. The wrist strap should be connected to a known good earth ground. If that is not possible, it should be connected to a conductive (metal) part of the assembly being worked on, but **not** to electronic components, exposed wires or traces, or pins on connectors.

4 General Maintenance

Take extra precautions, such as a grounded antistatic mat, if you must work on components or assemblies that have been removed from the MSD. This includes the analyzer.

CAUTION

To be effective, an antistatic wrist strap must fit snugly (not tight). A loose strap provides little or no protection.

Antistatic precautions are not 100% effective. Handle electronic circuit boards as little as possible and then only by the edges. Never touch components, exposed traces, or pins on connectors and cables.

Maintaining the Vacuum System

Periodic maintenance

As listed earlier in [Table 8](#), some maintenance tasks for the vacuum system must be performed periodically. These include:

- Checking the foreline pump fluid (every week)
- Checking the calibration vial (every 6 months)
- Ballasting the foreline pump (daily in MSDs using ammonia reagent gas)
- Replacing the foreline pump oil (every 6 months; every 3 months for CI MSDs using ammonia reagent gas, standard foreline pump)
- Tightening the foreline pump oil box screws (first oil change after installation, standard foreline pump)
- Replacing the diffusion pump fluid (once a year)
- Checking the dry foreline pump diaphragms (typically every 3 years)

Failure to perform these tasks as scheduled can result in decreased instrument performance. It can also result in damage to your instrument.

Other procedures

Tasks such as replacing a Micro-Ion vacuum gauge should be performed only when needed. See [“General Troubleshooting”](#) on page 29 and see the online help in the MSD ChemStation software for symptoms that indicate this type of maintenance is required.

More information is available

If you need more information about the locations or functions of vacuum system components, See [“Vacuum System”](#) on page 171.

Most of the procedures in this chapter are illustrated with video clips on this 5975 Series MSD User Information DVD.

To Remove the MSD Covers

Materials needed

- Screwdriver, Torx T-15 (8710-1622)

If you need to remove one of the MSD covers, follow these procedures (Figure 4):

NOTE

The color of the MSD cover will vary, depending upon the model type, but the installation and removal procedures are the same for all models.

To remove the analyzer top cover

Remove the five screws and lift the cover off.

To remove the left side cover

- 1 Open the analyzer cover.
- 2 Disconnect the narrow ribbon cable from the back of the local control panel.
- 3 Remove the three screws that hold the left side cover in place.
- 4 Pull the cover left slightly to disengage the two right side tabs and then pull it straight forward.

To remove the analyzer window cover

- 1 Press down on the rounded area on the top of the window.
- 2 Lift the window forward and off the MSD.

WARNING

Do not remove any other covers. Dangerous voltages are present under other covers.

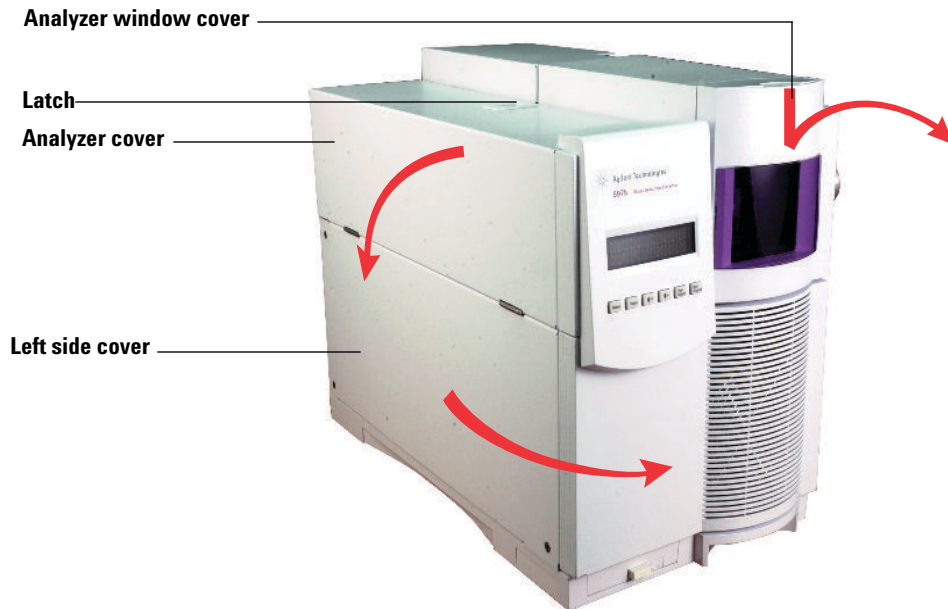

Figure 4 Removing covers

CAUTION

Do not use excessive force or the plastic tabs that hold the cover to the mainframe will break off.

To Connect the Micro-Ion Vacuum Gauge

The Micro-Ion vacuum gauge is optional for EI operation. It is **required** for operating the MSD in CI mode.

Materials needed

- Micro-Ion vacuum gauge (G3397A)
- Power cord
- Micro-Ion vacuum gauge cable (G3170-60805)
- CI flow module cable-Smart Card to CI flow (G3170-60808)

Procedure

- 1 Use the provided KF-16 clamp to install the Micro-Ion vacuum gauge to the rear of the analyzer chamber.
- 2 Connect the gauge cables as shown in [Figure 5](#).
- 3 Pump down the MSD.

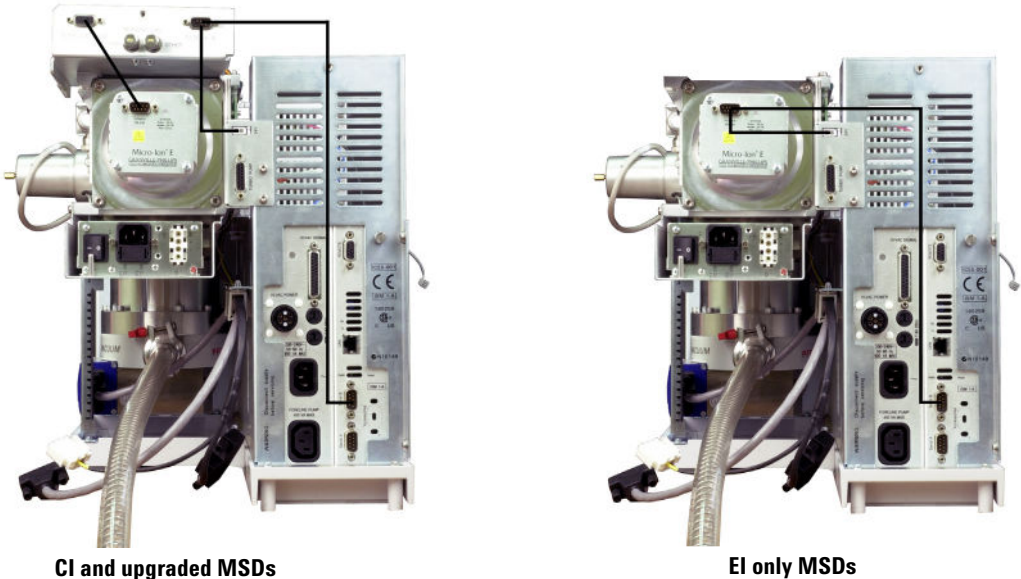

Figure 5 Micro-Ion vacuum gauge cables

To Move or Store the MSD

Materials needed

- Ferrule, blank (5181-3308)
- Interface column nut (05988-20066)
- Wrench, open-end, 1/4-inch × 5/16-inch (8710-0510)

Procedure

- 1 Vent the MSD.
- 2 Remove the column and install a blank ferrule and interface nut.
- 3 Tighten the vent valve.
- 4 Move the MSD away from the GC.
- 5 Unplug the GC/MSD interface heater cable from the GC.
- 6 Install the interface nut with the blank ferrule.
- 7 Open the analyzer cover.
- 8 Finger-tighten the side plate thumbscrews ([Figure 6](#)).

CAUTION

Do not overtighten the side plate thumbscrews. Overtightening will strip the threads in the analyzer chamber. It will also warp the side plate and cause leaks.

- 9 Plug the MSD power cord in.
- 10 Switch the MSD on to establish a rough vacuum. Verify that the turbo pump speed is greater than 50%.
- 11 Switch the MSD off.
- 12 Close the analyzer cover.
- 13 Disconnect the LAN, remote, and power cables.

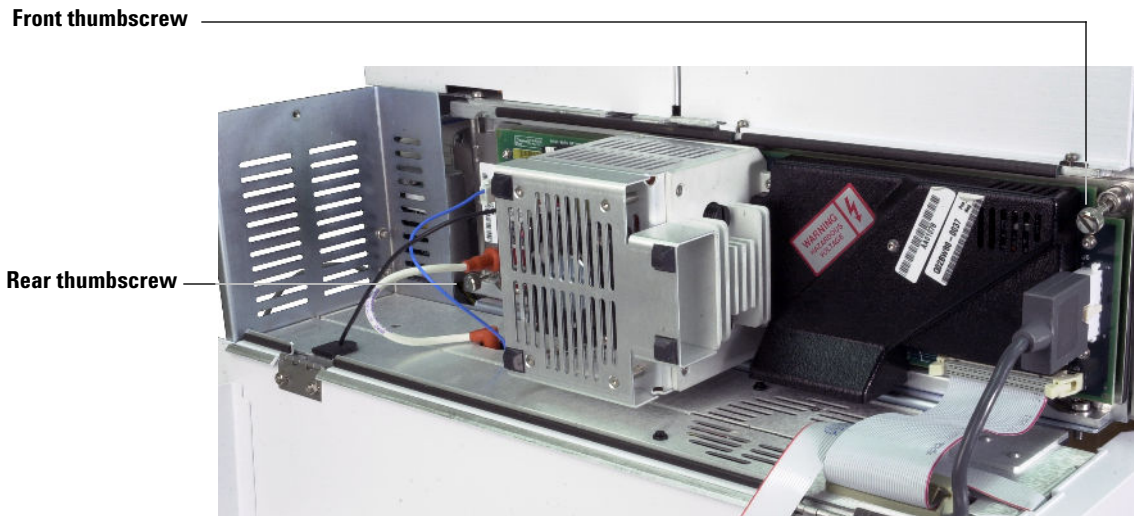

Figure 6 Side plate thumbscrews

The MSD can now be stored or moved. The foreline pump cannot be disconnected; it must be moved with the MSD. Make sure the MSD remains upright and is never tipped on its side or inverted.

CAUTION

The MSD must remain upright at all times. If you need to ship your MSD to another location, contact your Agilent Technologies service representative for advice about packing and shipping.

To Check and Add Foreline Pump Oil

Standard foreline pump only

Materials needed

- Foreline pump oil (6040-0621)
- Funnel (9301-6461)
- Hex key, 5-mm, to remove drain plug (8710-1838)
- Screwdriver, flat-blade, to remove top fill cap

Procedure

WARNING

The foreline pump can cause burns if touched when operating. It has a safety shield to prevent the user from touching it.

- 1 Examine the oil level window (Figure 7).

Note the two lines on the pump left of the window. The oil level should be between the lines. The foreline pump oil should be almost clear. If the oil level is near or below the lower line, follow steps 2 through 6 to add foreline pump oil.

WARNING

Never add oil while the foreline pump is on.

If your MSD is nearing its scheduled time for replacement of the foreline pump oil, replace the oil instead of adding oil. If the oil is dark or cloudy, replace it. See “[To Drain the Foreline Pump](#)” on page 98 for instructions about replacing the foreline pump oil.

- 2 Vent the MSD.
- 3 Remove the foreline pump fill cap.
- 4 Add pump fluid until the oil level in the window is near, but not above, the upper line.

- 5 Reinstall the fill cap.
- 6 Pump down the MSD.

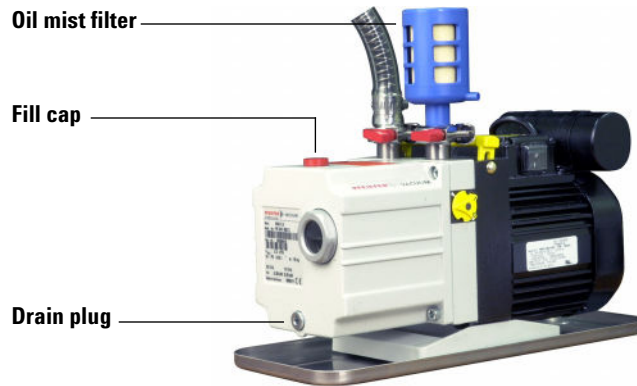
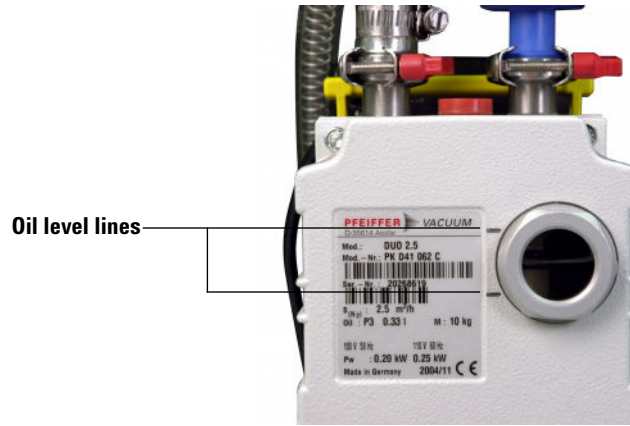

Figure 7 Foreline pump (standard pump shown without safety cage)

To Drain the Foreline Pump

Standard foreline pump only

Materials needed

- Book or other solid object approximately 5 cm thick
- Container for catching old pump oil, 500 mL
- Gloves, oil- and solvent-resistant
- Screwdriver, flat-blade, large (8730-0002)
- Hex key, 5-mm (8710-1838)

Procedure

WARNING

The foreline pump can cause burns if touched when operating. It has a safety shield to prevent the user from touching it.

- 1 Vent the MSD.
- 2 If necessary, slide the foreline pump to a safe, accessible location.

The foreline pump may be located on the floor, on the lab bench next to or behind the MSD, or under the analyzer chamber at the back of the MSD.

WARNING

The foreline pump may be hot.

- 3 Place a book or other object under the pump motor to tilt it up slightly. Remove the fill cap. See [Figure 7](#).
- 4 Place a container under the drain plug.
- 5 Remove the drain plug. Allow the pump oil to drain out. The oil drains faster if it is still warm.

WARNING

The old pump oil may contain toxic chemicals. Treat it as hazardous waste.

- 6 Replace the drain plug after draining the oil.
- 7 Refill the foreline pump until the oil level is between the two fill marks in the site window.
- 8 Replace the fill cap.

To Refill the Foreline Pump

Standard foreline pump only

Materials needed

- Foreline pump oil (6040-0621) – approximately 0.28 L required
- Funnel (9301-6461)
- Gloves, oil- and solvent-resistant
- Screwdriver, flat-blade, large (8730-0002)
- Drain plug O-ring (if required) (0905-1515)
- Hex key, 5-mm (8710-1838)

Procedure

WARNING

The foreline pump can cause burns if touched when operating. It has a safety shield to prevent the user from touching it.

- 1 Drain the foreline pump. See [page 98](#).
- 2 Reinstall the drain plug. If the old O-ring appears worn or damaged, replace it.
- 3 Remove the propping object from under the pump motor.
- 4 Add foreline pump oil until the oil level in the window is near, but not above, the upper line. The foreline pump requires approximately 0.28 L of oil.
- 5 Wait a few minutes for the oil to settle. If the oil level drops, add oil to bring the oil level near the upper line.
- 6 Reinstall the fill cap.
- 7 If necessary, slide the foreline pump back under the analyzer chamber.

The foreline pump may be located on the floor, on the lab bench next to or behind the MSD, or under the analyzer chamber at the back of the MSD.
- 8 Pump down the MSD.

To Check the Diffusion Pump Fluid

Materials needed

- Screwdriver, Torx T-15 (8710-1622)

Procedure

- 1 Remove the analyzer window cover.

WARNING

Do not remove any other covers. Removing other covers may expose hazardous voltages.

- 2 Vent the MSD.

- 3 Remove the side cover.

WARNING

Keep your hair away from the cooling fan if the MSD is turned on.

- 4 Check the diffusion pump fluid level. See [Figure 8](#).

The diffusion pump fluid level can be seen through the window below the fan at the front of the MSD. The diffusion pump fluid level should be between the top and bottom of one of the **FULL** ranges. There are two sets of marks. Use the **HOT** marks if the diffusion pump is on and is at its normal operating temperature. Use the **COLD** marks if the pump is off and has had time to cool. If the fluid level is below the bottom of the appropriate range, replace the diffusion pump fluid. Do not just add fluid.

The pump fluid should be clear or almost clear. Dark or cloudy pump fluid indicates an air leak or excessive heat. If the pump fluid appears dark or cloudy, replace it. Then, check for an air leak.

The diffusion pump fluid should be replaced at least once a year, or more often if the pump fluid level is low or if the fluid is dark or cloudy.

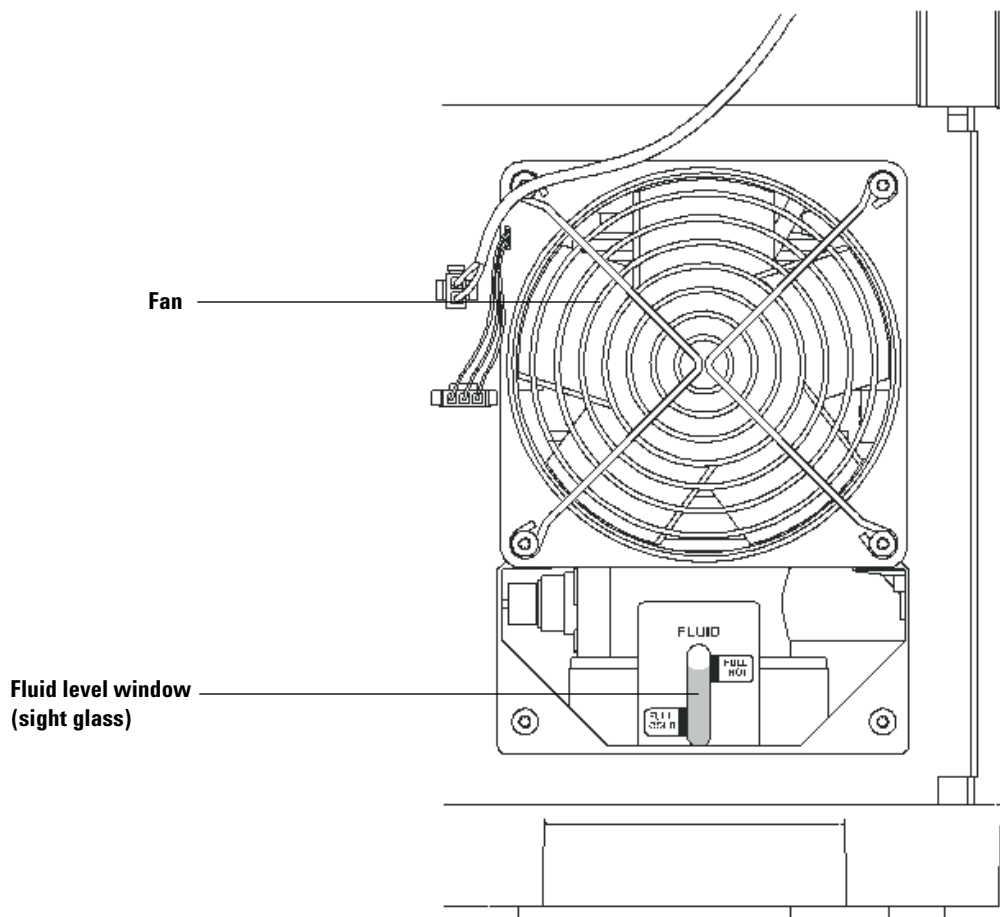

Figure 8 Diffusion pump

To Separate the MSD from the GC

Materials needed

- Wrench, open-end, 1/4-inch × 5/16-inch (8710-0510)

Procedure

- 1 Vent the MSD.
- 2 Turn off the GC.

WARNING

Make sure the GC/MSD interface and GC oven have cooled before you remove the column.

- 3 Remove the capillary column from the GC/MSD interface.
- 4 The foreline pump may be located on the floor, on the lab bench next to or behind the MSD, or under the analyzer chamber at the back of the MSD. Move it as needed to provide slack in the tubing and cables.
- 5 Move the MSD away from the GC until you have access to the GC/MSD interface cable (Figure 9).
- 6 Place a column nut with a blank ferrule on the end of the interface. This will help keep contamination out of the MSD.
- 7 Disconnect the GC/MSD interface cable. Disconnecting the cable with the GC on can cause a fault condition.
- 8 Continue to move the MSD until you have access to the part requiring maintenance.



Interface cable

5975 Series MSD and Agilent 7890A, 7820A and 6890 GCs

Agilent 7890A GC has a front and a back location for the MSD interface.

Agilent 6890 GC has only one (front) location.

Agilent 7820A GC has only one location for the MSD interface.



Interstitial panel

5975 Series MSD and 6850 GC

6850 GC has only one location for the MSD interface. The interstitial panel is needed to set the proper distance between the GC and the MSD.

Figure 9 Separating/Connecting the MSD and GC

To Reconnect the MSD to the 7890A GC/7820A/6890 GC

Materials needed

- Wrench, open-end, 1/4-inch × 5/16-inch (8710-0510)

Procedure

- 1 Position the MSD so the end of the GC/MSD interface is near the GC (Figure 9).
- 2 Reconnect the GC/MSD interface cable.
- 3 Slide the MSD to its regular position next to the GC.

Be careful not to damage the GC/MSD interface as it passes into the GC. Make sure the end of the GC/MSD interface extends into the GC oven.

- 4 The foreline pump may be located on the floor, on the lab bench next to or behind the MSD, or under the analyzer chamber at the back of the MSD.
- 5 Reinstall the capillary column.
- 6 Pump down the MSD.
- 7 Turn on the GC. Enter appropriate temperature setpoints for the GC/MSD interface and GC oven.

To Reconnect the MSD to the 6850 GC

Materials needed

- Wrench, open-end, 1/4-inch × 5/16-inch (8710-0510)
- Screwdriver, Torx T-15 (8710-1622)

Procedure

- 1 Position the MSD so that it is near the GC.
- 2 If not installed, install the GC/MSD interstitial panel (part number G2589-00031) onto the midsupport and front-support legs of the right side of the MSD. Use three M4 T-15 screws. See [Figure 10](#).

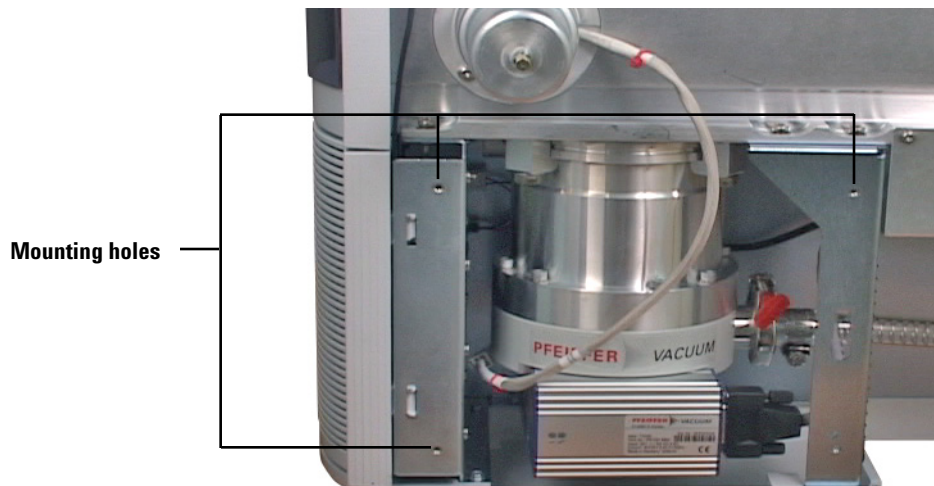

Figure 10 GC/MSD interstitial panel mounting holes (turbo pump shown)

- 3 Connect the GC and the MSD end of the GC/MSD interface cable. See [Figure 11](#).



Figure 11 Interstitial panel installed, GC/MSD interface cable connected

- 4 Carefully push the MSD and GC together.

4 General Maintenance

When positioned properly, the end of the GC/MSD interface cover will touch the oven wall and the GC/MSD interface tip will protrude slightly into the GC oven. See [Figure 12](#).



Figure 12 MSD and 6850 GC properly positioned

- 5 The foreline pump may be located on the floor, on the lab bench next to or behind the MSD, or under the analyzer chamber at the back of the MSD. Move it as needed to provide slack in the tubing and cables.
- 6 Reinstall the capillary column.
- 7 Pump down the MSD.
- 8 Turn on the GC. Enter appropriate temperature setpoints for the GC/MSD interface and GC oven.

To Refill the EI Calibration Vial

Materials needed

- PFTBA (05971-60571)

Procedure

- 1 Stop any tuning or data acquisition.
- 2 Turn off the analyzer. There are several ways to do this:
 - In the Tune and Vacuum Control view, select **MS OFF** from the Execute menu.
 - In the Instrument Control view in the Edit Parameters dialog box, select **MS OFF** from the Execute menu.
- 3 If your MSD is equipped with a vacuum gauge, turn off the gauge.
- 4 Remove the analyzer window cover.
- 5 Loosen the calibration vial collar (Figure 13). Do not remove the collar.
- 6 Pull the calibration vial out. You may feel some resistance due to residual vacuum.

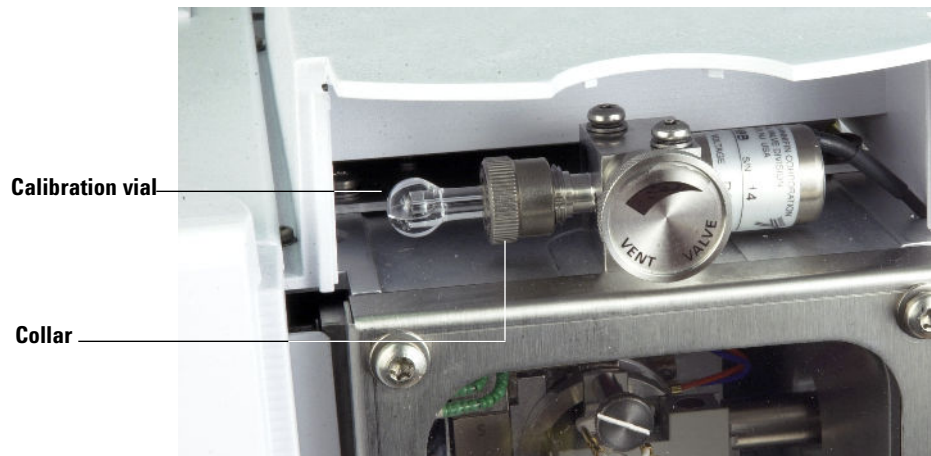

Figure 13 Removing the EI calibration vial

4 General Maintenance

- 7 Syringe or pipette PFTBA into the vial. With the vial vertical, the liquid should be just below the end of the internal tube, approximately 70 μL of sample.
- 8 Push the calibration vial into the valve as far as possible.
- 9 Withdraw the vial 1 mm. This prevents damage when you tighten the collar.
- 10 Turn the collar clockwise to tighten it.

The collar should be snug but not overly tight. Do **not** use a tool to tighten the collar. It does not require that much force.

- 11 Reinstall the analyzer window cover.
- 12 Select **Purge Calibrant Valve** from the Vacuum menu in the Tune and Vacuum Control view.

CAUTION

Failure to purge the calibration valve will result in damage to the filaments and detector.

To Purge the Calibration Valves

CAUTION

After removing a calibrant vial, you **must** purge the calibration valve. Failure to do so will result in damage to the filaments and the electron multiplier.

El calibration valve

After adding new PFTBA to the calibrant vial, you must purge the air out of the vial and valve.

- 1 If the vacuum gauge controller is on, turn it off.
- 2 In Tune and Vacuum Control view, select **Purge Calibrant Valve** under the Vacuum menu.

This will open the CI calibration valve for several minutes with all analyzer voltages turned off.

CI calibration valve

After adding new PFDTD to the calibrant vial, you must purge the air out of the vial and valve.

- 1 If the vacuum gauge controller is on, turn it off.
- 2 Select **Gas A**.
- 3 Verify that **PCICH4.U** is loaded.
- 4 In Diagnostics and Vacuum Control view, select **Purge Calibrant Valve** under the Vacuum menu.

This will open the CI calibration valve for several minutes with all analyzer voltages turned off.

To Remove the EI Calibration and Vent Valve Assembly

Materials needed

- Screwdriver, Torx T-15 (8710-1622)

Procedure

- 1 Vent the MSD.
- 2 Trace the calibration valve cable to the connector next to the fan and disconnect it.
- 3 Loosen the collar and remove the calibration vial (Figure 13). Just loosen the collar, do not remove it.

CAUTION

Removing the valve with the vial installed can result in liquid calibrant getting into the restrictor of the valve. Liquid in the restrictor will prevent diffusion of PFTBA into the analyzer chamber for tuning. Replace the valve if this happens.

- 4 Remove the two screws holding the valve assembly to the top of the analyzer chamber. Do not lose the O-ring under it.

To Reinstall the EI Calibration and Vent Valve Assembly

Materials needed

- Calibration valve (G3170-60204)
- O-ring for calibration valve (0905-1217)
- PFTBA (05971-60571) or other tuning compound
- Screwdriver, Torx T-15 (8710-1622)

Procedure

- 1 Remove the old valve assembly. See [page 112](#) and [Figure 13](#).
- 2 Be sure the valve O-ring is in place. If it is worn or damaged, replace it.
- 3 Install the calibration and vent valve assembly and tighten the screws that hold it in place.
- 4 Reconnect the calibration valve cable to the connector next to the fan.
- 5 Remove the vial from the new calibration valve. See [page 109](#). The valve is supplied with a vial already installed.
- 6 Fill and reinstall the calibration vial. See [page 109](#).
- 7 Pump down the MSD.
- 8 Select **Purge Calibrant Valve** from the Vacuum menu in the Tune and Vacuum Control view.

CAUTION

Failure to purge the calibration valve will damage the filaments and detector.

To Replace the Fan for the High Vacuum Pump

Materials needed

- Fan (G1099-60564)
- Screwdriver, Torx T-15 (8710-1622)

Procedure

- 1 Vent the MSD.
- 2 Remove the left side MSD cover.
- 3 Disconnect the fan wiring from the connector on the MSD frame (Figure 14).
- 4 Remove the four fan screws and the safety grill. Remove the fan. Keep the screws.

WARNING

Do not touch the high vacuum pump. The pump could still be hot enough to burn you.

- 5 Disconnect the fan wiring from the old fan. The fan wiring ends in a small connector on the back of the fan.
- 6 Connect the fan wiring to the new fan.
- 7 Install the new fan with the flow arrow on the side pointing toward the pump. The wires should be at the upper left, close to the connector.
- 8 Add the safety grill and the four screws. Tighten the screws firmly.

WARNING

Make sure the safety grill that shields the fan blades is in place.

- 9 Connect the fan wiring to the fan connector on the MSD frame.
- 10 Reinstall the MSD covers.
- 11 Pump down the MSD.

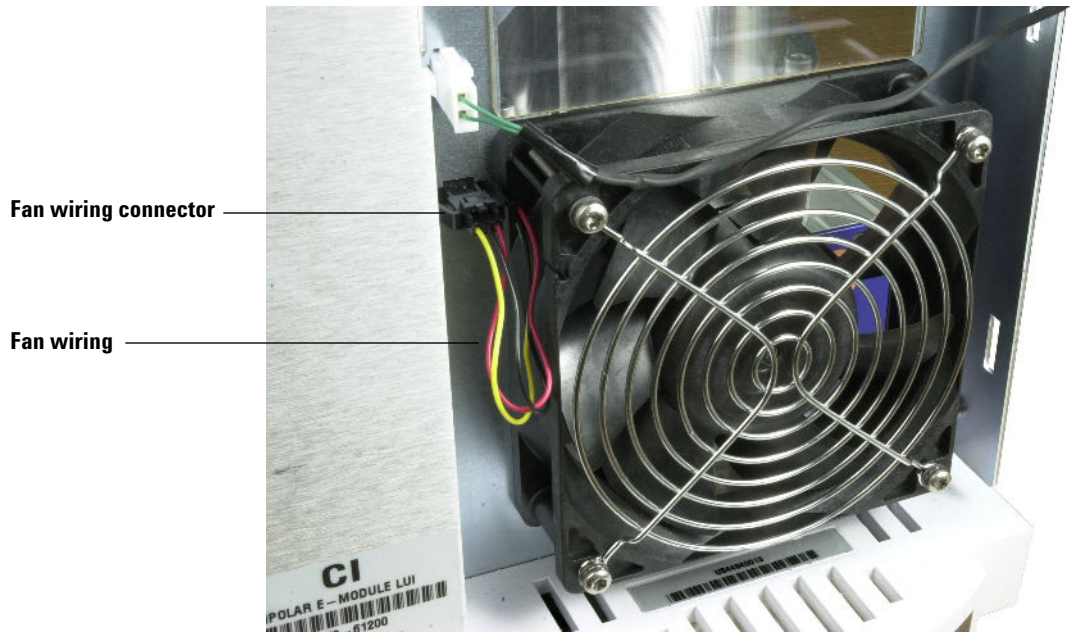

Figure 14 Replacing the pump fan (turbo pump shown)

To Remove the Micro-Ion Vacuum Gauge

Procedure

- 1** Vent the MSD.
- 2** Disconnect the cable on the back of the Micro-Ion vacuum gauge.
- 3** Unscrew the red plastic thumbnut on the gauge clamp.
- 4** Remove the long screw from the clamp.
- 5** While supporting the gauge body, remove the clamp from the mounting flange.
- 6** Remove the gauge.
- 7** If you will not be replacing the gauge soon, install the blanking plate provided with the gauge and secure it with the clamp, screw, and thumbnut.

To Reinstall a Micro-Ion Vacuum Gauge

Material needed

- KF16 O-ring 0905-1463

Procedure



- 1 Place the KF16 O-ring in the groove on the analyzer chamber flange. Replace it if it is worn or damaged.
- 2 Hold the gauge flange against the chamber flange with the O-ring. Push the clamp over both flanges.
- 3 Insert the long screw, add the thumbnut, and tighten.
- 4 Attach the cable to the back of the gauge.

To Lubricate the Side Plate O-Ring

Materials needed

- Cloths, clean (05980-60051)
- Gloves, clean, lint-free
 - Large (8650-0030)
 - Small (8650-0029)
- Grease, Apiezon L, high vacuum (6040-0289)

The side plate O-ring needs a thin coat of grease to ensure a good vacuum seal. If the side plate O-ring appears dry or does not seal correctly, lubricate it using this procedure. A good test is to wipe off the side plate with methanol, then close the analyzer chamber. If the O-ring has enough grease on it, it will leave a faint trace on the side plate.

CAUTION

Vacuum seals other than the side plate O-ring and vent valve O-ring do not need to be lubricated. Lubricating other seals can interfere with their correct function.

Procedure

- 1 Vent the MSD.
- 2 Open the analyzer chamber.
- 3 Use a clean, lint-free cloth or glove to spread a *thin* coat of high vacuum grease only on the exposed surface of the O-ring (Figure 15).

CAUTION

Do not use anything except the recommended vacuum grease. Excess grease can trap air and dirt. Grease on surfaces of the O-ring other than the exposed surface can trap air, resulting in air spikes during operation.

- 4 Use a clean, lint-free cloth or glove to wipe away excess grease. If the O-ring looks shiny, there is too much grease on it.
- 5 Close the analyzer chamber.
- 6 Pump down the MSD.

Side plate O-ring



Figure 15 Side plate O-ring

To Lubricate the Vent Valve O-Ring

Materials needed

- Cloths, clean (05980-60051)
- Gloves, clean, lint-free
 - Large (8650-0030)
 - Small (8650-0029)
- Grease, Apiezon L, high vacuum (6040-0289)
- O-ring, vent valve (0905-1217). Replace if the old O-ring is worn or damaged

The vent valve O-ring needs a thin coat of lubrication to ensure a good vacuum seal and smooth operation. If the vent valve O-ring does not turn smoothly or does not seal correctly, lubricate it using this procedure.

CAUTION

Vacuum seals other than the side plate O-ring and vent valve O-ring do not need to be lubricated. Lubricating other seals can interfere with their correct function.

Procedure

- 1 Vent the MSD.
- 2 Completely remove the vent valve knob (Figure 16).
- 3 Inspect the O-ring. If the O-ring appears damaged, replace it.
- 4 Use a clean, lint-free cloth or glove to spread a *thin* coat of high vacuum grease on the exposed surface of the O-ring.

CAUTION

Excess grease can trap air and dirt. Grease on surfaces of the O-ring other than the exposed surface can trap air, resulting in air spikes during operation.

- 5 Use a clean, lint-free cloth or glove to wipe away excess grease. If the O-ring looks shiny, there is too much grease on it

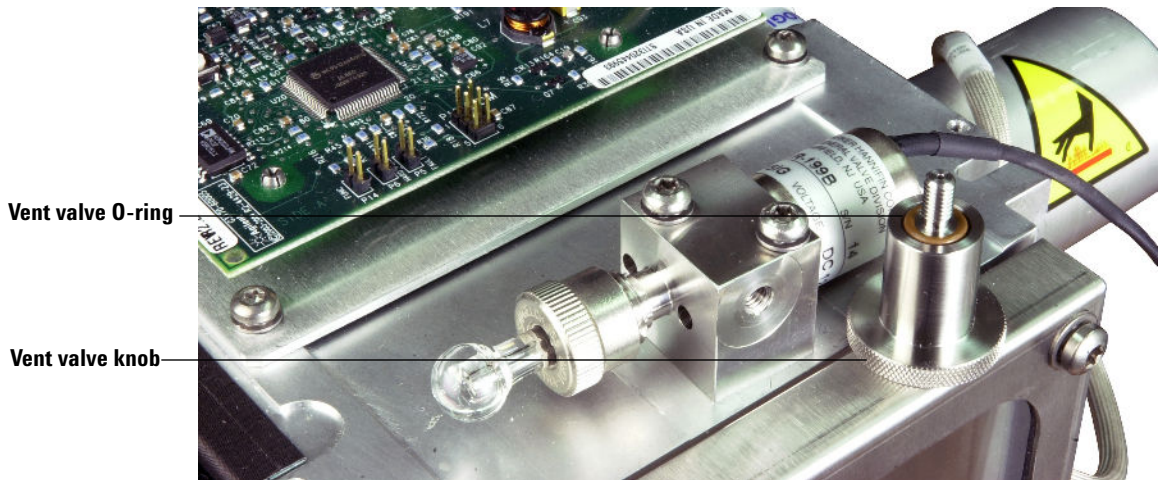

Figure 16 Vent valve O-ring

- 6 Reinstall the vent valve knob.

CAUTION

Be very careful when reinstalling the vent valve knob. It is possible to cross thread the knob and damage the threads in the valve body. Be sure the O-ring stays in place.

- 7 Pump down the MSD.

To Remove the Diffusion Pump

WARNING

The diffusion pump fluid may contain traces of toxic chemicals.

Materials needed

- Aluminum foil, clean
- Gloves, oil-resistant

Procedure

- 1 Vent the MSD.
- 2 Separate the MSD from the GC. See [“To Separate the MSD from the GC”](#) on page 103.
- 3 Disconnect the foreline gauge assembly from the diffusion pump outlet. The foreline gauge cable can be disconnected or can remain connected to the foreline gauge.
- 4 Disconnect the diffusion pump temperature sensor wires from the wiring harness.
- 5 Disconnect high vacuum power (HIVAC POWER) cable from the back panel of the MSD. (This is the thick black cable that emerges near the bottom of the pump.)
- 6 Support the diffusion pump with one hand.

- 7 Remove the KF50 clamp. See Figure 17.

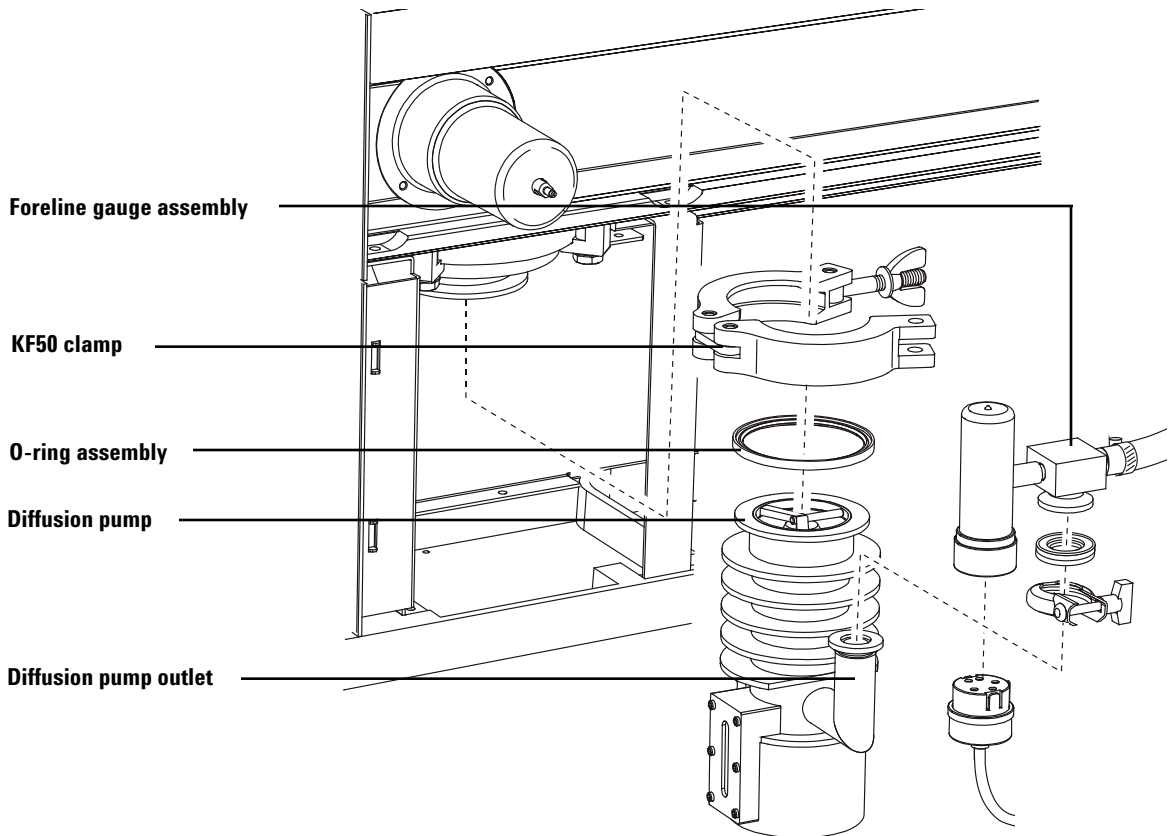

Figure 17 Removing the diffusion pump

- 8 Lower the diffusion pump.
- 9 Remove the O-ring assembly from the top of the diffusion pump. The O-ring will have diffusion pump fluid on it and will be very sticky. Place the O-ring on clean aluminum foil (shiny side down) to keep your lab bench and the O-ring clean.
- 10 Remove the diffusion pump through the side of the MSD. You may have to tilt the pump slightly to remove it. Do not tilt the pump past 45 ° if the pump is warm.

To Replace the Diffusion Pump Fluid

Materials needed

- Aluminum foil, clean
- Cloths, clean, lint-free (05980-60051)
- Container for old diffusion pump fluid
- Diffusion pump fluid, 18.5 mL (6040-0809) – 2 required
- Gloves
 - Oil- and solvent-resistant
 - Thermally insulated

Procedure

- 1 Remove the diffusion pump from the MSD. See [page 122](#). Make sure you remove the O-ring assembly from the top of the diffusion pump.
- 2 Cover the top of the diffusion pump with aluminum foil (shiny side up).

WARNING

The pump and pump fluid will be hot. Wear protective gloves when you remove the pump from the oven.

- 3 Heat the diffusion pump at 60 °C for 15 minutes. (For 6890, 7820A, or 7890A GC's you can use the GC oven.)

WARNING

Treat the old pump fluid as hazardous. It may contain traces of toxic chemicals.

- 4 Pour the old diffusion pump fluid out the top of the pump. Even after heating, the pump fluid pours very slowly.

WARNING

Methylene chloride is a hazardous solvent. Work in a fume hood and take all appropriate precautions.

- 5 Check the color of the pump fluid.

If the diffusion pump has been heated with insufficient pump fluid (or with a large air leak in the MSD), the remaining pump fluid may be severely charred and blackened. Blackened pump fluid may also be baked onto the internal parts (stack) of the pump. If so, you may have to remove the diffusion pump stack and clean its parts, and the interior of the pump, with methylene chloride. Be very careful when reinstalling the stack. Misalignment of stack components can seriously reduce diffusion pump performance.

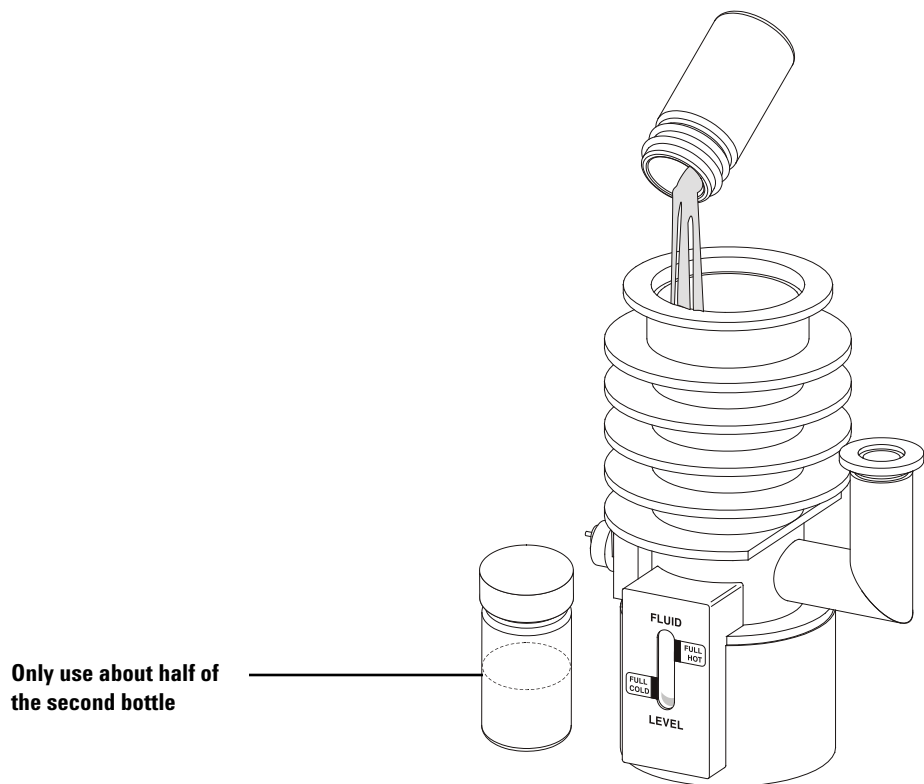

Figure 18 Filling the diffusion pump with fluid

- 6 Clean the diffusion pump flange on the analyzer chamber.

4 General Maintenance

- 7 Preheat the new diffusion pump fluid following the instructions on the bottle.
- 8 Pour new diffusion pump fluid into diffusion pump until the fluid level is within the FULL COLD range.

The recommended charge for this pump is 30 mL. It will require approximately 1.5 of the bottles (18.5 mL each) of diffusion pump fluid. Pour the fluid between the center stack and the side wall. Watch the sight glass while pouring. Do not overfill.

- 9 Reinstall the diffusion pump. See [page 127](#).

To Reinstall the Diffusion Pump

Materials needed

- Gloves, oil-resistant
- Vacuum cleaner, non-ESD generating (92175V or equivalent)

This procedure works best with two people, one to hold the pump and one to install the clamp.

Procedure

- 1** Vacuum the fan that cools the diffusion pump.
Keeping the fan clean helps ensure maximum cooling. This is one of the few times you will have convenient access to the pump side of the fan.
- 2** Slide the diffusion pump into the MSD.
You may have to tilt the pump slightly to get it into the MSD. Do not tilt it past 45 degrees.
- 3** Install the O-ring assembly on the diffusion pump. See [Figure 19](#).
- 4** Lift the diffusion pump into its normal position.
- 5** Install the KF50 clamp.
- 6** Reconnect the diffusion pump temperature sensor wires to the wiring harness.
- 7** Reconnect the high vacuum power cable to the HIVAC POWER connector on the back panel of the MSD. This is the thick black cable that emerges near the bottom of the pump.
- 8** Reconnect the foreline gauge fitting to the outlet of the diffusion pump.
If you disconnected the foreline gauge cable, reconnect it to the foreline gauge.
- 9** Move the MSD back to its normal position.

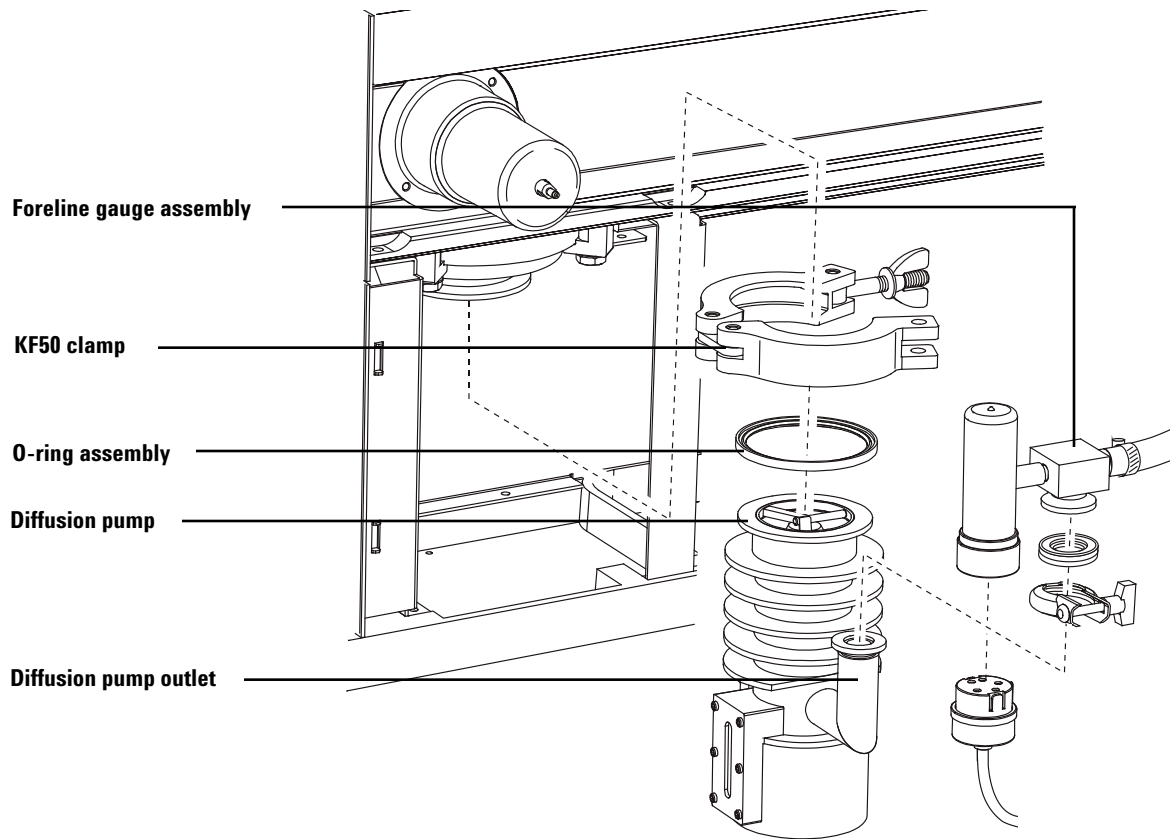

Figure 19 Reinstalling the diffusion pump

To Remove the Foreline Gauge

Materials needed

- Screwdriver, flat-blade, large (8730-0002)

Procedure

- 1 Vent the MSD.
- 2 Separate the MSD from the GC. See [page 103](#).

WARNING

The foreline pump and diffusion pump may still be hot.

- 3 Unplug the foreline gauge cable from the foreline gauge.
- 4 Disconnect the foreline gauge assembly from the diffusion pump outlet.
- 5 Loosen the hose clamp.

CAUTION

Be sure the MSD is vented to atmosphere before breaking the seal at the foreline gauge. **Never** vent the MSD at the pump end; use the vent valve.

- 6 Pull the foreline gauge assembly out of the foreline hose.

To Reinstall the Foreline Gauge

Materials needed

- Foreline gauge assembly (G1099-60545)
- Screwdriver, flat-blade, large (8730-0002)

Procedure

- 1 Connect a new foreline gauge assembly to the foreline hose.
- 2 Tighten the hose clamp.
- 3 Reconnect the foreline gauge cable to the foreline gauge.
- 4 Reconnect the foreline gauge assembly to the diffusion pump outlet.
- 5 Reconnect the MSD to the GC. See [page 105](#) and [page 106](#) for details.
- 6 If necessary, slide the foreline pump back under the analyzer chamber. The foreline pump may be located on the floor, on the lab bench next to or behind the MSD, or under the analyzer chamber at the back of the MSD.
- 7 Pump down the MSD.

Maintaining the Analyzer

Scheduling

None of the analyzer components require periodic maintenance. Some tasks, however, must be performed when MSD behavior indicates they are necessary. These tasks include:

- Cleaning the ion source
- Replacing filaments
- Replacing the electron multiplier horn

“General Troubleshooting” on page 29 provides information about symptoms that indicate the need for analyzer maintenance. The troubleshooting material in the online help in the MSD ChemStation software provides more extensive information.

Precautions

Cleanliness

Keep components clean during analyzer maintenance. Analyzer maintenance involves opening the analyzer chamber and removing parts from the analyzer. During analyzer maintenance procedures, take care to avoid contaminating the analyzer or interior of the analyzer chamber. Wear clean gloves during all analyzer maintenance procedures. After cleaning, parts must be thoroughly baked out before they are reinstalled. After cleaning, analyzer parts should be placed only on clean, lint-free cloths.

CAUTION

If not done correctly, analyzer maintenance can introduce contaminants into the MSD.

WARNING

The analyzer operates at high temperatures. Do not touch any part until you are sure it is cool.

Some parts can be damaged by electrostatic discharge

The wires, contacts, and cables connected to the analyzer components can carry electrostatic discharges (ESD) to the electronics boards to which they are connected. This is especially true of the mass filter (quadrupole) contact wires which can conduct ESD to sensitive components on the side board. ESD damage may not cause immediate failure but will gradually degrade performance and stability. See [page 87](#) for more information.

CAUTION

Electrostatic discharges to analyzer components are conducted to the side board where they can damage sensitive components. Wear a grounded antistatic wrist strap (see [page 87](#)) and take other antistatic precautions **before** you open the analyzer chamber.

Some analyzer parts should not be disturbed

The mass filter (quadrupole) requires no periodic maintenance. In general, the mass filter should never be disturbed. In the event of extreme contamination, it can be cleaned, but such cleaning should only be done by a trained Agilent Technologies service representative. The HED ceramic insulator must never be touched.

CAUTION

Incorrect handling or cleaning of the mass filter can damage it and have a serious, negative effect on instrument performance. Do not touch the HED ceramic insulator.

More information is available

If you need more information about the locations or functions of analyzer components, refer to [Chapter 7, “Analyzer”](#) on page 197.

Many procedures in this chapter are illustrated with video clips.

To disassemble the EI ion source

Materials needed

- Gloves, clean, lint-free
 - Large (8650-0030)
 - Small (8650-0029)
- Hex ball driver, 1.5 mm (8710-1570)
- Hex ball driver, 2.0 mm (8710-1804)
- Wrench, open-end, 10 mm (8710-2353)

Procedure

- 1 Remove the ion source. See the *Operation Manual*.
- 2 Remove the filaments (Figure 20).
- 3 Separate the repeller assembly from the source body. The repeller assembly includes the source heater assembly, repeller, and related parts.
- 4 Remove the repeller.
- 5 Unscrew the interface socket. A 10-mm open-end wrench fits the flats on the interface socket.
- 6 Remove the setscrew for the lenses.
- 7 Push the lenses out of the source body.

NOTE

Video shows the standard Ion Source Assembly procedures.

4 General Maintenance

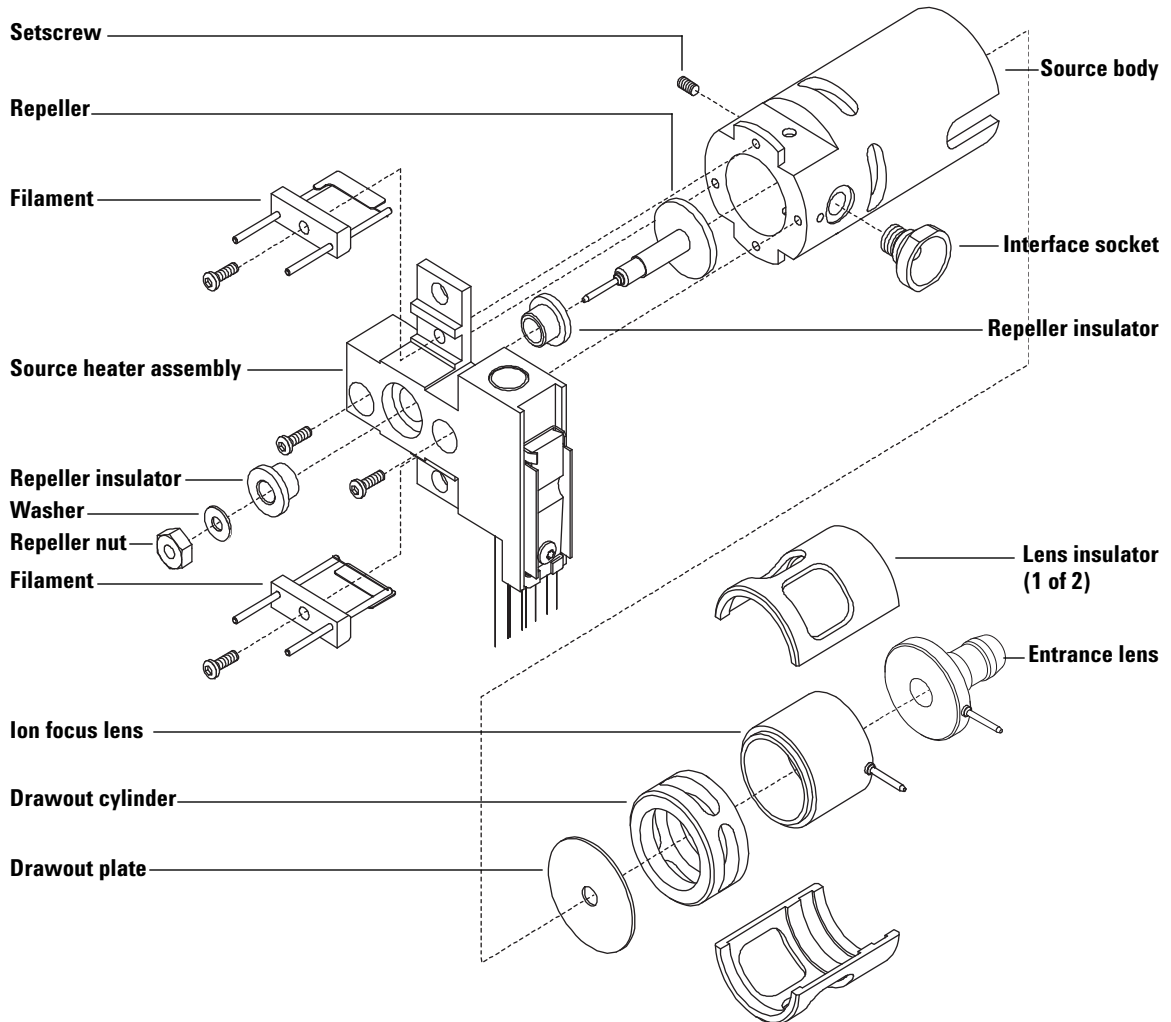

Figure 20 Disassembling the EI ion source

To clean the EI ion source

Materials needed

- Abrasive paper (5061-5896)
- Alumina abrasive powder (8660-0791)
- Aluminum foil, clean
- Cloths, clean (05980-60051)
- Cotton swabs (5080-5400)
- Glass beakers, 500 mL
- Gloves, clean, lint-free
 - Large (8650-0030)
 - Small (8650-0029)
- Solvents
 - Acetone, reagent grade
 - Methanol, reagent grade
 - Methylene chloride, reagent grade
- Ultrasonic bath

Preparation

- 1 Disassemble the ion source. See [page 133](#).
- 2 Collect the following parts to be cleaned: ([Figure 21](#))
 - Repeller
 - Interface socket
 - Source body
 - Drawout plate
 - Drawout cylinder
 - Ion focus lens
 - Entrance lens

These are the parts that contact the sample or ion beam. The other parts normally should not require cleaning.

4 General Maintenance

CAUTION

If insulators are dirty, clean them with a cotton swab dampened with reagent-grade methanol. If that does not clean the insulators, replace them. Do not abrasively or ultrasonically clean the insulators.

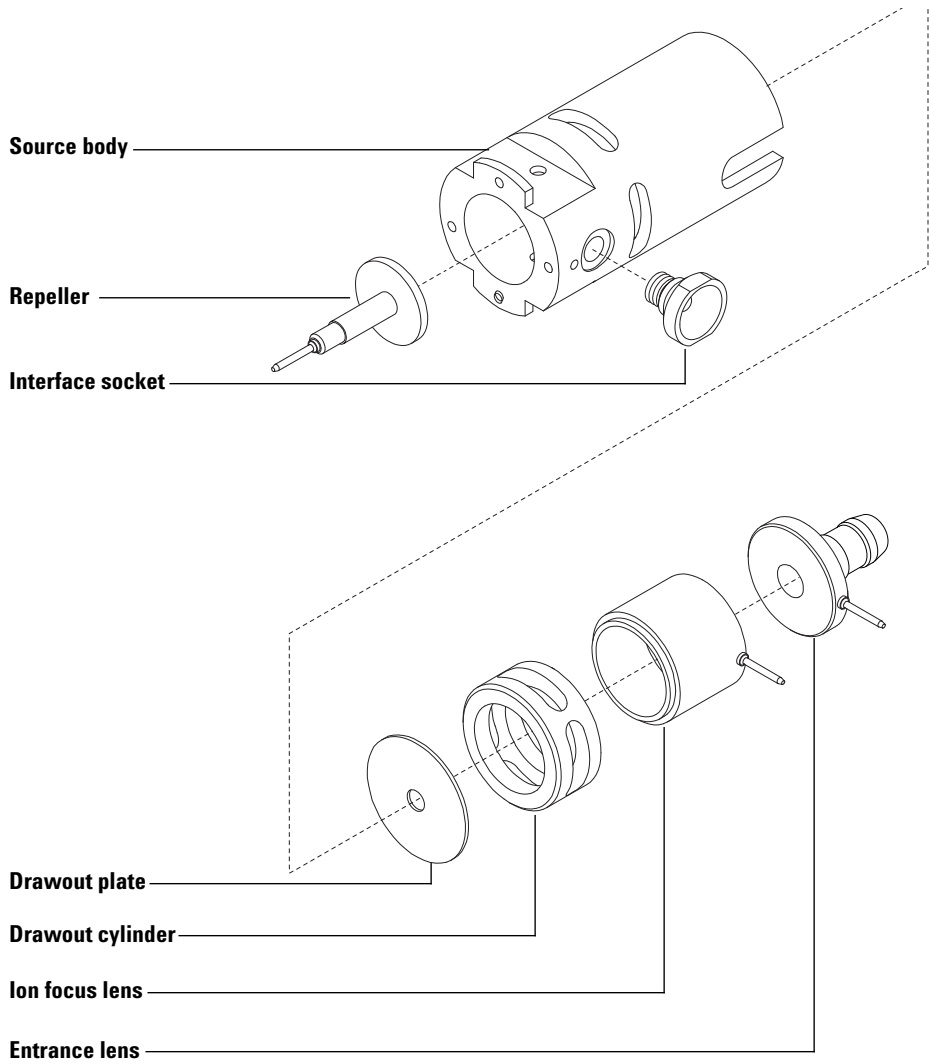

Figure 21 Source parts to be cleaned

Procedure

CAUTION

The filaments, source heater assembly, and insulators cannot be cleaned ultrasonically. Replace these components if major contamination occurs.

- 3 If the contamination is serious, such as an oil backflow into the analyzer, seriously consider replacing the contaminated parts.
- 4 Abrasively clean the surfaces that contact the sample or ion beam.

Use an abrasive slurry of alumina powder and reagent-grade methanol on a cotton swab. Use enough force to remove all discolorations. Polishing the parts is not necessary; small scratches will not harm performance. Also abrasively clean the discolorations where electrons from the filaments enter the source body.

- 5 Rinse away all abrasive residue with reagent-grade methanol.

Make sure **all** abrasive residue is rinsed way **before** ultrasonic cleaning. If the methanol becomes cloudy or contains visible particles, rinse again.

- 6 Separate the parts that were abrasively cleaned from the parts that were not abrasively cleaned.
- 7 Ultrasonically clean the parts (each group separately) for 15 minutes in each of the following solvents:
 - Methylene chloride (reagent-grade)
 - Acetone (reagent-grade)
 - Methanol (reagent-grade)

WARNING

All of these solvents are hazardous. Work in a fume hood and take all appropriate precautions.

- 8 Place the parts in a clean beaker. **Loosely** cover the beaker with clean aluminum foil (dull side down).
- 9 Dry the cleaned parts in an oven at 100 °C for 5–6 minutes.

WARNING

Let the parts cool before you handle them.

NOTE

Take care to avoid recontaminating cleaned and dried parts. Put on new, clean gloves before handling the parts. Do not set the cleaned parts on a dirty surface. Set them only on clean, lint-free cloths.

To reassemble the EI ion source

Materials needed

- Gloves, clean, lint-free
 - Large (8650-0030)
 - Small (8650-0029)
- Hex ball driver, 1.5 mm (8710-1570)
- Hex ball driver, 2.0 mm (8710-1804)
- Wrench, open-end, 10 mm (8710-2353)

Procedure

- 1 Slide the drawout plate and the drawout cylinder into the source body (Figure 22).
- 2 Assemble the ion focus lens, entrance lens, and lens insulators.
- 3 Slide the assembled parts into the source body.
- 4 Install the setscrew that holds the lenses in place.
- 5 Reinstall the repeller, repeller insulators, washer, and repeller nut into the source heater assembly.

The resulting assembly is called the repeller assembly.

CAUTION

Do not overtighten the repeller nut or the ceramic repeller insulators will break when the source heats up. The nut should only be finger-tight.

- 6 Reconnect the repeller assembly to the source body. The repeller assembly includes the source heater assembly, repeller, and related parts.
- 7 Reinstall the filaments.
- 8 Reinstall the interface socket

CAUTION

Do not overtighten the interface socket. Overtightening could strip the threads.

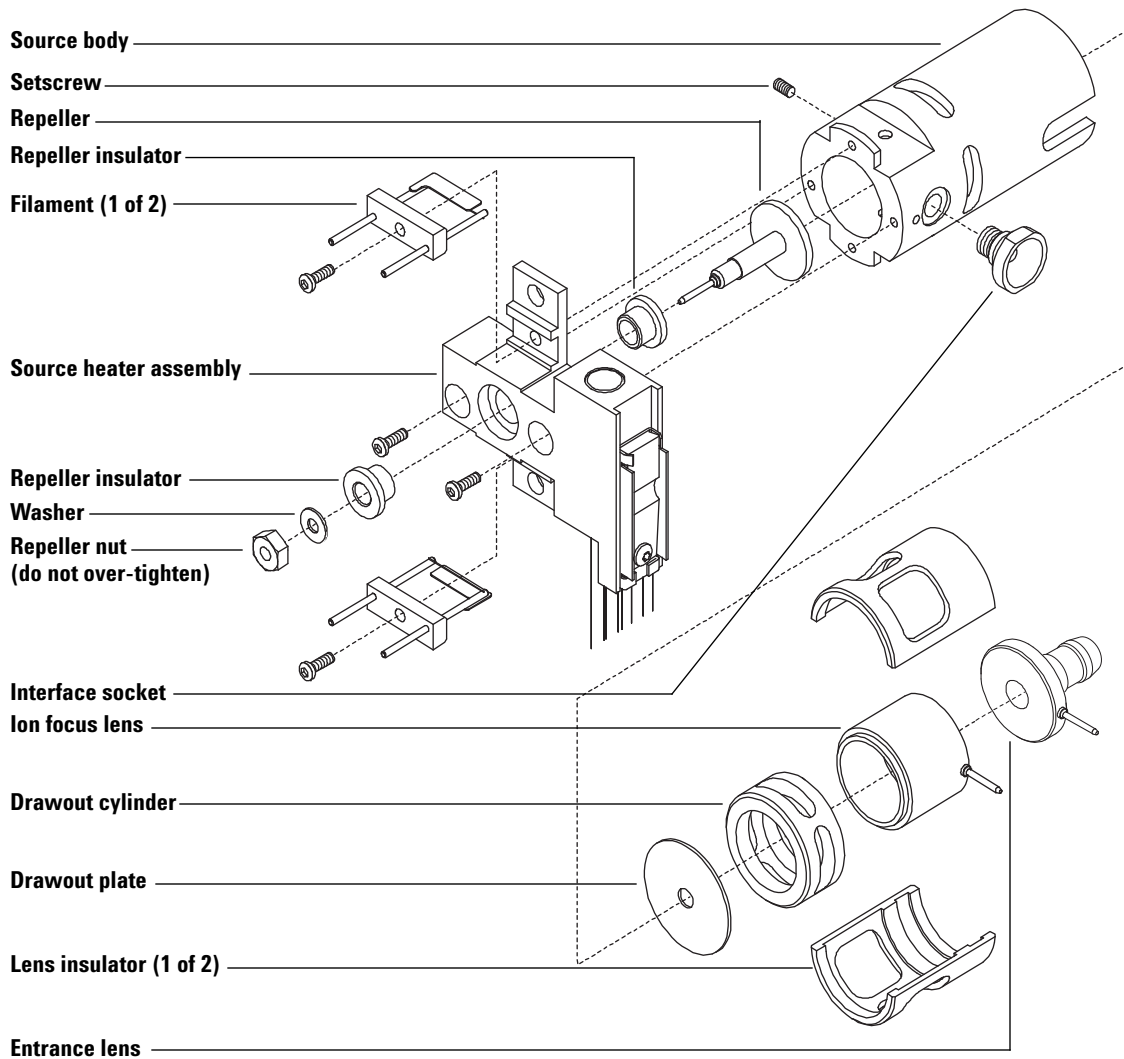

Figure 22 Assembling the ion source

To remove a filament

Materials needed

- Gloves, clean, lint-free
 - Large (8650-0030)
 - Small (8650-0029)
- Hex ball driver, 1.5-mm (8710-1570)

Procedure

- 1 Vent the MSD.
- 2 Open the analyzer chamber.
- 3 Remove the ion source. See the *Operation Manual*.
- 4 Remove the filament(s) to be replaced ([Figure 23](#)).

WARNING

The analyzer operates at high temperatures. Do not touch any part until you are sure it is cool.

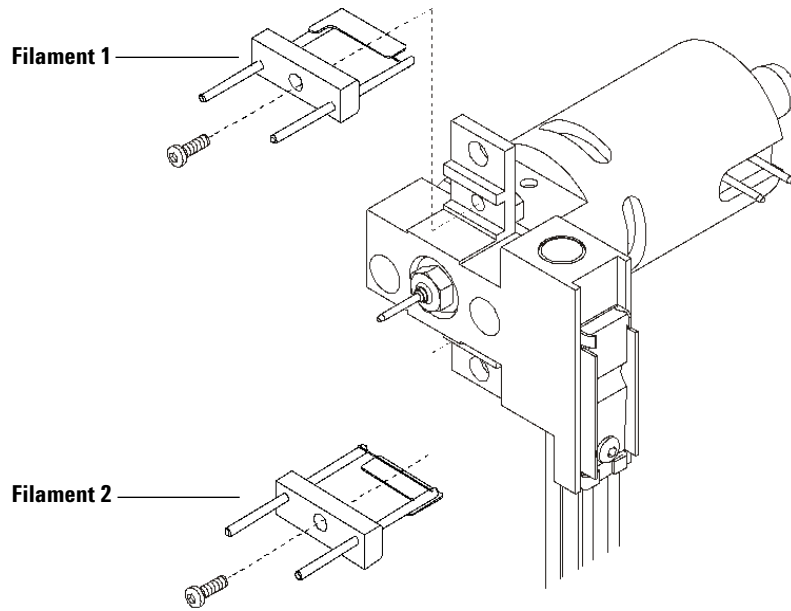

Figure 23 Replacing filaments

To reinstall a filament

Materials needed

- Filament assembly (G2590-60053)
- Gloves, clean, lint-free
 - Large (8650-0030)
 - Small (8650-0029)
- Hex ball driver, 1.5 mm (8710-1570)

Procedure

- 1 Install the new filament ([Figure 23](#)).
- 2 Remove the screw holding the filament to the ion source body.
- 3 Slide off the filament assembly.
- 4 Orient the assembly so that the filament is next to the ion source body.
- 5 Replace the screw to the ion source body.
- 6 After installing the filament, verify that it is not grounded to source body.
- 7 Reinstall the ion source. See the *Operation Manual*.
- 8 Close the analyzer chamber.
- 9 Pump down the MSD.
- 10 Autotune the MSD.
- 11 In the Edit Parameters dialog box (Instrument/Edit MS Tune Parameters), select the other filament.
- 12 Autotune the MSD again.
- 13 Select and use the filament that gives the best results.

If you decide to use the first filament, run Autotune again to make sure the tune parameters are compatible with the filament.

- 14 Select **Save Tune Parameters** from the File menu.

To remove the heater and sensor from the ion source

Materials needed

- Gloves, clean, lint-free
 - Large (8650-0030)
 - Small (8650-0029)
- Hex ball driver, 1.5 mm (8710-1570)
- Hex ball driver, 2.0 mm (8710-1804)
- Hex nut driver, 5.5 mm (8710-1220)

Procedure

- 1 Vent the MSD.
- 2 Open the analyzer chamber.
- 3 Remove the ion source from the source radiator. See the *Operation Manual*.
- 4 Remove the filaments.
- 5 Remove the repeller assembly (Figure 24). The repeller assembly includes the source heater assembly, repeller, and related parts.
- 6 Remove the repeller nut, washer, repeller insulators, and repeller.

You do not need to remove the heater and temperature sensor from the heater block. The new source heater assembly includes all three parts already assembled.

4 General Maintenance

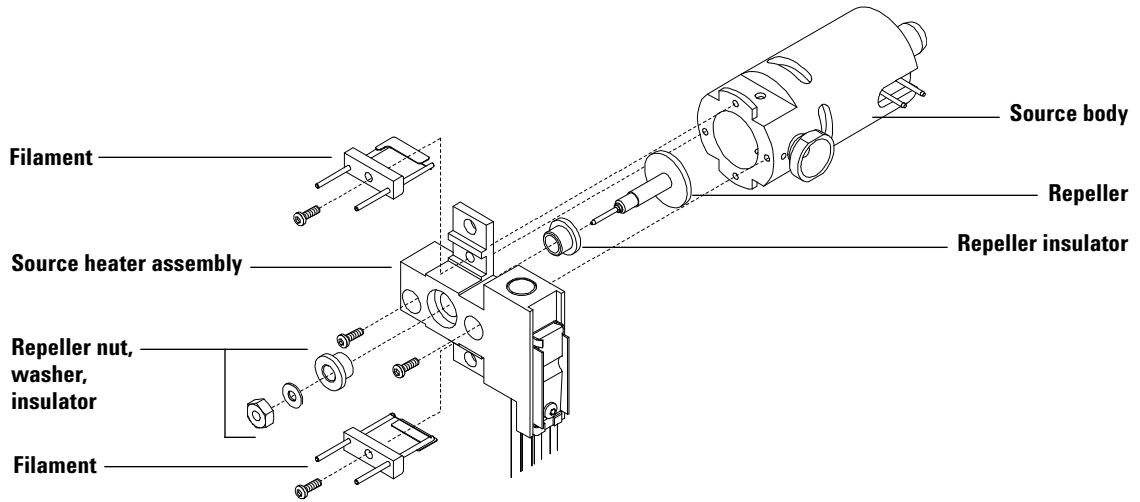

Figure 24 Replacing the heater and sensor

To reinstall the heater and sensor in the ion source

Materials needed

- Gloves, clean, lint-free
 - Large (8650-0030)
 - Small (8650-0029)
- Hex ball driver, 1.5 mm (8710-1570)
- Hex ball driver, 2.0 mm (8710-1804)
- Hex nut driver, 5.5 mm (8710-1220)
- Source heater assembly (G3169-60177)

Procedure

- 1 Unpack the new source heater assembly. The heater, temperature sensor, and heater block are already assembled.
- 2 Reinstall the repeller, repeller insulators, washer, and repeller nut (Figure 24). The resulting assembly is called the repeller assembly.

CAUTION

Do not overtighten the repeller nut or the ceramic repeller insulators will break when the source heats up. The nut should only be finger-tight.

- 3 Connect the repeller assembly to the source body.
- 4 Reinstall the filaments.
- 5 Reinstall the ion source in the source radiator. See the *Operation Manual*.
- 6 Reconnect the wires from the feedthrough board to the ion source.
- 7 Reconnect the heater and temperature sensor wires to the feedthrough board.
- 8 Close the analyzer chamber.
- 9 Pump down the MSD.

To remove the heater and sensor from the mass filter

Materials needed

- Gloves, clean, lint-free
 - Large (8650-0030)
 - Small (8650-0029)
- Hex ball driver, 1.5 mm (8710-1570)
- Hex ball driver, 2.0 mm (8710-1804)

Procedure

- 1 Vent the MSD.
- 2 Open the analyzer chamber.
- 3 Disconnect the mass filter heater and temperature sensor wires from the feedthrough board.
- 4 Remove the mass filter heater assembly from the mass filter radiator.

CAUTION

Do not touch the mass filter contact leads. This could cause ESD damage to the side board.

To reinstall the heater and sensor in the mass filter

Materials needed

- Gloves, clean, lint-free
 - Large (8650-0030)
 - Small (8650-0029)
- Hex ball driver, 1.5 mm (8710-1570)
- Hex ball driver, 2.0 mm (8710-1804)
- Mass filter heater assembly (G1099-60172)

Procedure

- 1** Unpack the new mass filter heater assembly ([Figure 25](#)). The heater, temperature sensor, and heater block are already assembled.
- 2** Install the heater assembly on top of the mass filter radiator.
- 3** Connect the heater and temperature sensor wires to the feedthrough board.
- 4** Close the analyzer chamber.
- 5** Pump down the MSD.

CAUTION

Do not touch the mass filter contact leads. This could cause ESD damage to the side board.

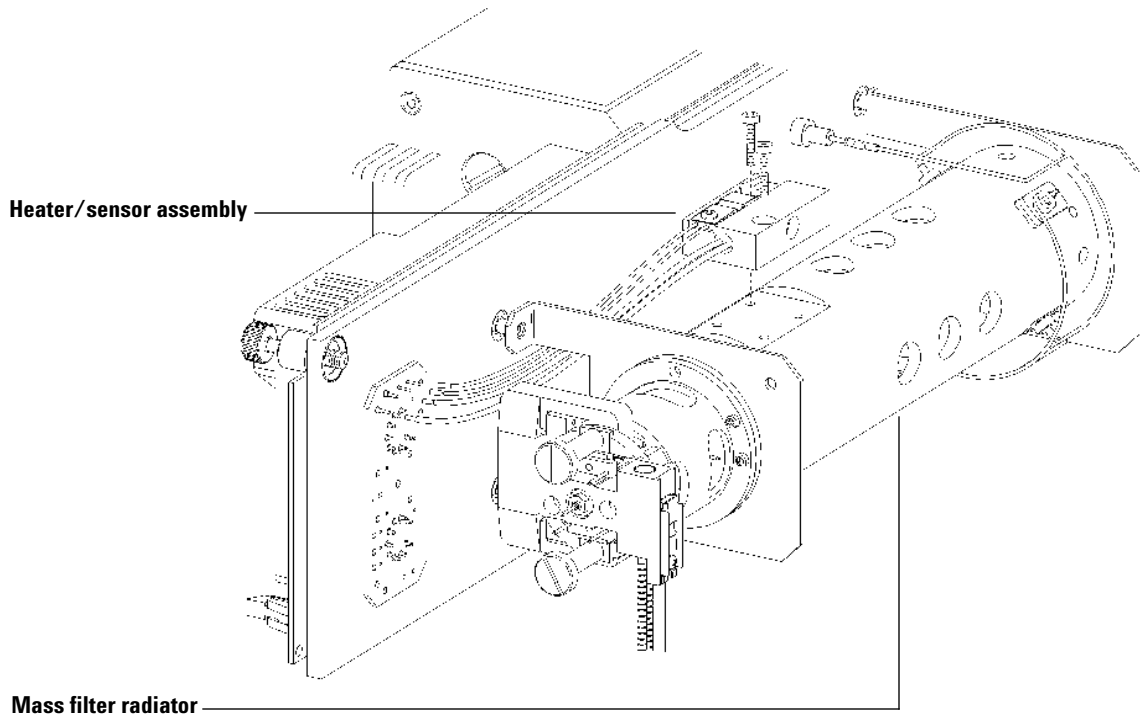

Figure 25 Mass filter heater and sensor

To replace the electron multiplier horn

Materials needed

- Electron multiplier horn (G3170-80103)
- Gloves, clean, lint-free
 - Large (8650-0030)
 - Small (8650-0029)

Procedure

- 1 Vent the MSD.
- 2 Open the analyzer chamber.
- 3 Open the retaining clip ([Figure 26](#)). Lift the arm of the clip up and then swing the clip away from the electron multiplier horn.
- 4 Remove the electron multiplier horn.
- 5 Install the new electron multiplier horn.
- 6 Close the retaining clip.

The signal pin on the horn must rest ***on the outside*** of the loop in the contact strip. ***Do not*** put the signal pin on the inside of the loop in the contact strip. Incorrect installation will result in poor sensitivity or no signal.

- 7 Close the analyzer chamber.

4 General Maintenance

- 8 Pump down the MSD.

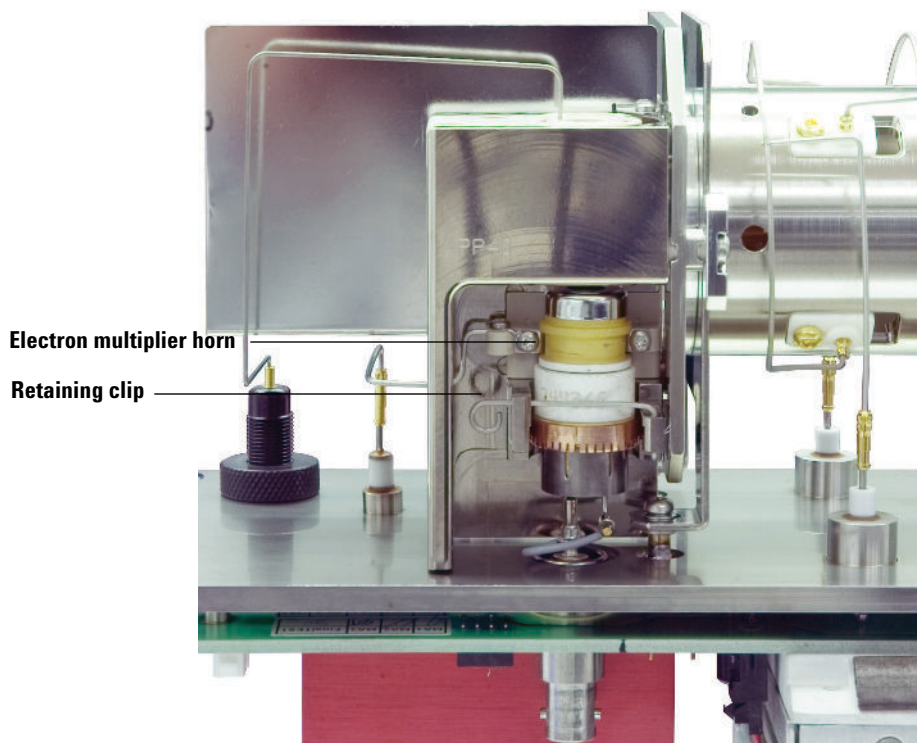

Figure 26 Replacing the electron multiplier horn

Maintaining the GC/MSD Interface

The GC/MSD interface requires no periodic maintenance

Rarely, the heater cartridge in the GC/MSD interface fails. In those cases, it is necessary to replace the heater and sensor. This section contains procedures for removing the heater and sensor and installing new ones. See [Figure 28](#).

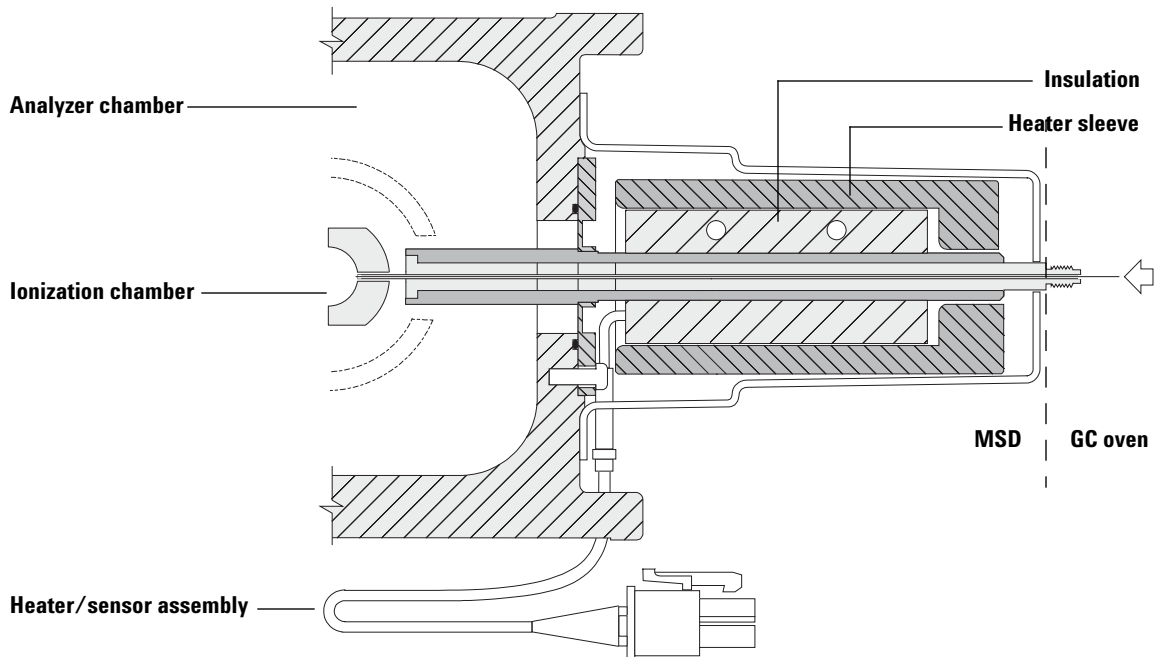

Figure 27 EI GC/MSD interface

To remove the GC/MSD interface heater and sensor

Materials needed

- Screwdriver, Torx T-15 (8710-1622)
- Hex driver, 1.5 mm (8710-1570)

Procedure

- 1 Vent the MSD.
- 2 Make sure you turn off the GC/MSD interface heater. This heater is controlled and powered by the GC.
- 3 Separate the MSD from the GC.
- 4 Remove the cover from the GC/MSD interface.

WARNING

The GC/MSD interface operates a very high temperatures. It is also well insulated. Make sure the interface is cool *before* you touch it.

- 5 Slide the insulation off of the GC/MSD interface (Figure 28).
- 6 Loosen the two heater sleeve screws.
- 7 Slide the heater sleeve off of the GC/MSD interface. It may be necessary to ***gently*** pry open the slot in the heater sleeve to loosen the heater sleeve from the interface.
- 8 Loosen the setscrew and remove the heater and temperature sensor from the heater sleeve.

Heat and oxidation often result in a heater or, less frequently, a temperature sensor being “welded” inside the heater sleeve. The holes for the heater and sensor pass all the way through the heater sleeve. A rod can be inserted to drive the stuck part out. However, to function correctly the heater and sensor must have perfect contact with their holes. If a heater or sensor is difficult to remove, the holes will probably be damaged enough that the heater sleeve should be replaced. Polishing the holes is not an acceptable solution since it will enlarge the holes.

CAUTION

Installing a new heater and sensor in a damaged heater sleeve will result in poor performance of the heated zone and could reduce the lifetime of the new parts.

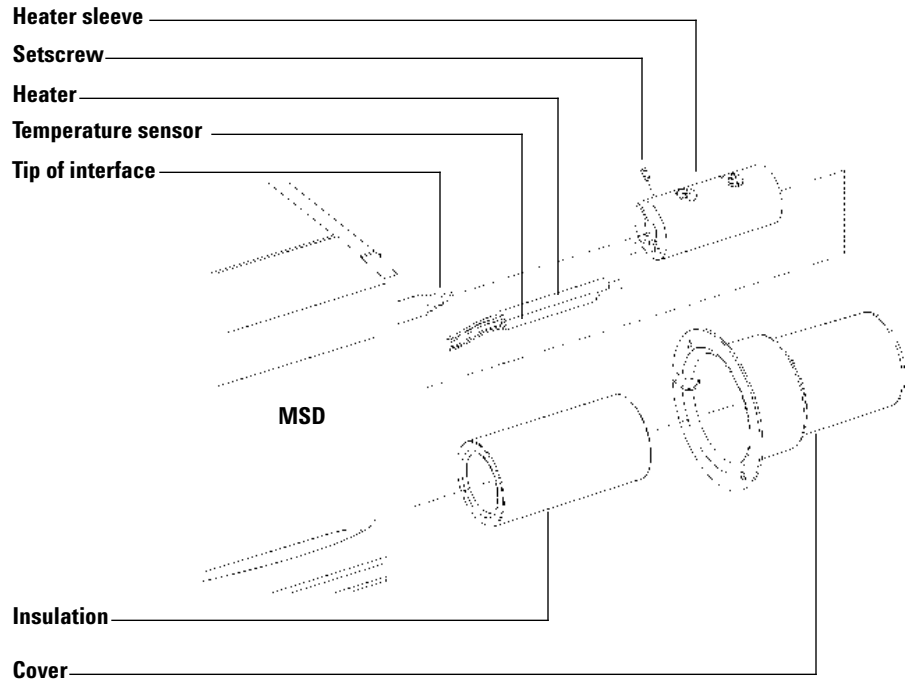

Figure 28 Replacing the GC/MSD interface heater and sensor

To reinstall the GC/MSD interface heater and sensor

Materials needed

- GC/MSD interface heater assembly (G1099-60107)
- Heater sleeve (G1099-20210); replace the old sleeve if it is damaged
- Screwdriver, Torx T-15 (8710-1622)
- Hex driver, 1.5 mm (8710-1570)

Procedure

- 1 Slide the new heater and temperature sensor into the heater sleeve (Figure 28).
- 2 Reinstall the setscrew.
- 3 Slide the heater sleeve onto the GC/MSD interface. Align the heater sleeve so the screws are on top. Tighten the screws evenly.
- 4 Slide the insulation onto the GC/MSD interface.

CAUTION

There is a shallow groove along the inner surface of the insulation. This groove **must** line up with the heads of the screws in the heater sleeve. If it does not, you can crack or otherwise damage the insulation.

- 5 Reinstall the GC/MSD interface cover. Make sure the wires from the heater and sensor pass through the cutout in the interface cover.
- 6 Reconnect the MSD to the GC. See [page 105](#).
- 7 Reconnect the GC/MSD interface cable to the GC. Reinstall the capillary column.
- 8 Pump down the MSD.
- 9 Turn on the GC. Enter appropriate temperature setpoints for the GC/MSD interface and GC oven.

Maintaining the Electronics

Scheduled maintenance

None of the electronic components of the MSD need to be replaced on a regular schedule. None of the electronic components in the MSD need to be adjusted or calibrated on a regular schedule. Avoid unnecessary handling of the MSD electronics.

Electronic components

Very few of the electronic components are operator serviceable. The primary fuses can be replaced by the operator. The RF coils can be adjusted by the operator. All other maintenance of the electronics should be performed by your Agilent Technologies service representative.

WARNING

Improper use of these procedures could create a serious safety hazard. Improper use of these procedures could also result in serious damage to, or incorrect operation of, the MSD.

WARNING

Vent the MSD and disconnect its power cord before performing any of these procedures *except* adjusting the RF coils.

Electrostatic precautions

All of the printed circuit boards in the MSD contain components that can be damaged by electrostatic discharge (ESD). Do not handle or touch these boards unless absolutely necessary. In addition, wires, contacts, and cables can conduct ESD to the printed circuit boards to which they are connected. This is especially true of the mass filter (quadrupole) contact wires which can carry ESD to sensitive components on the side board. ESD damage may not cause immediate failure but it will gradually degrade the performance and stability of your MSD.

When you work on or near printed circuit boards, or when you work on components with wires, contacts, or cables connected to printed circuit boards, always use a grounded antistatic wrist strap and take other antistatic

precautions. The wrist strap should be connected to a known good earth ground. If that is not possible, it should be connected to a conductive (metal) part of the assembly being worked on, but **not** to electronic components, exposed wires or traces, or pins on connectors.

Take extra precautions, such as a grounded antistatic mat, if you must work on components or assemblies that have been removed from the MSD. This includes the analyzer.

CAUTION

In order to be effective, an antistatic wrist strap must fit snugly (not tight). A loose strap provides little or no protection.

CAUTION

Antistatic precautions are not 100% effective. Handle electronic circuit boards as little as possible and then only by the edges. Never touch the components, exposed traces, or pins on connectors and cables.

More information is available

If you need more information about the functions of electronic components, refer to [Chapter 8](#), “[Electronics](#)” on page 215.

Most of the procedures in this chapter are illustrated with video clips.

To adjust the quad frequency

Materials needed

- Screwdriver, flat-blade, large (8730-0002)

Procedure

- 1 Make sure the MSD is at thermal equilibrium. It takes at least 2 hours *after* all heated zones have reached their setpoints for the MSD to reach thermal equilibrium.
- 2 Open the analyzer cover.

WARNING

Do not remove any other covers. Dangerous voltages are present under these covers.

- 3 Make sure the RF cover on the side board is secure and no screws are missing. A loose RF cover or missing screw can *significantly* affect coil adjustment.
- 4 In the Tune and Vacuum Control view, select **Optimize Quadrupole Frequency** from the Execute menu.
- 5 Enter an m/z value of 100.
- 6 Slowly turn the quad frequency adjustment screws to minimize the voltage displayed (Figure 29).

Turn the adjustment screws alternately. Turn each screw only a little bit at a time. Keep the screws at *equal* extension. The minimum voltage is typically between 50 and 70 mV.

CAUTION

Do not use a coin to adjust the screws. If you drop it, it could fall into the electronics fan and cause significant damage.

- 7 When the voltage is minimized, click **Stop**.

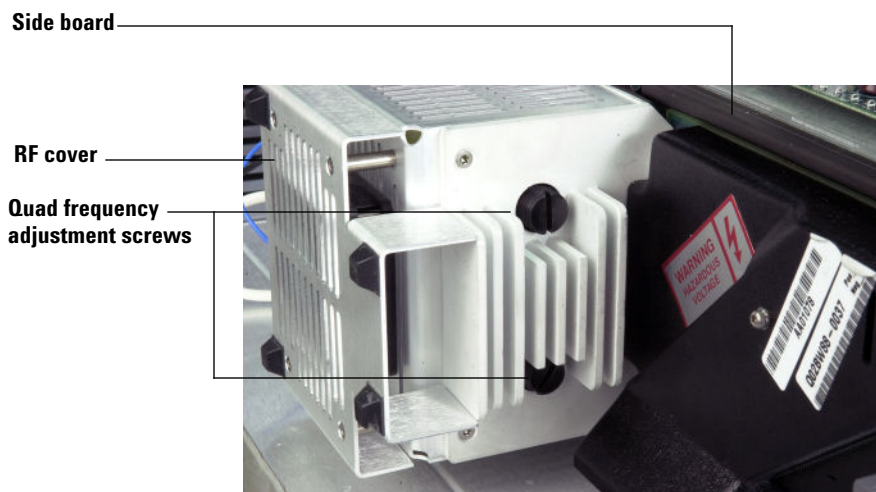

Figure 29 Adjusting the quad frequency

- 8** Repeat steps 4 through 7 for m/z 650. The minimum voltage is typically between 300 and 340 mV.
- 9** Exit the Set Optimize Quadrupole Frequency program.
- 10** Select **MS OFF** from the Execute menu.
- 11** Close the analyzer cover.
- 12** Tune the MSD.

To replace the primary fuses

Materials needed

- Fuse, T8 A, 250 V (2110-0969) – 2 required
- Screwdriver, flat-blade (8730-0002)

The most likely cause of failure of the primary fuses is a problem with the foreline pump. If the primary fuses in your MSD fail, check the foreline pump.

Procedure

- 1 Vent the MSD and unplug the power cord from the electrical outlet.

If one of the primary fuses has failed, the MSD will already be off, but for safety you should switch off the MSD and unplug the power cord. It is not necessary to allow air into the analyzer chamber.

WARNING

Never replace the primary fuses while the MSD is connected to a power source.

WARNING

If you are using hydrogen as a GC carrier gas, a power failure may allow it to accumulate in the analyzer chamber. In that case, further precautions are required. See “Hydrogen Safety” on page 20.

- 2 Turn one of the fuse holders (Figure 30) counterclockwise until it pops out. The fuse holders are spring loaded.
- 3 Remove the old fuse from the fuse holder.
- 4 Install a new fuse in the fuse holder.
- 5 Reinstall the fuse holder.

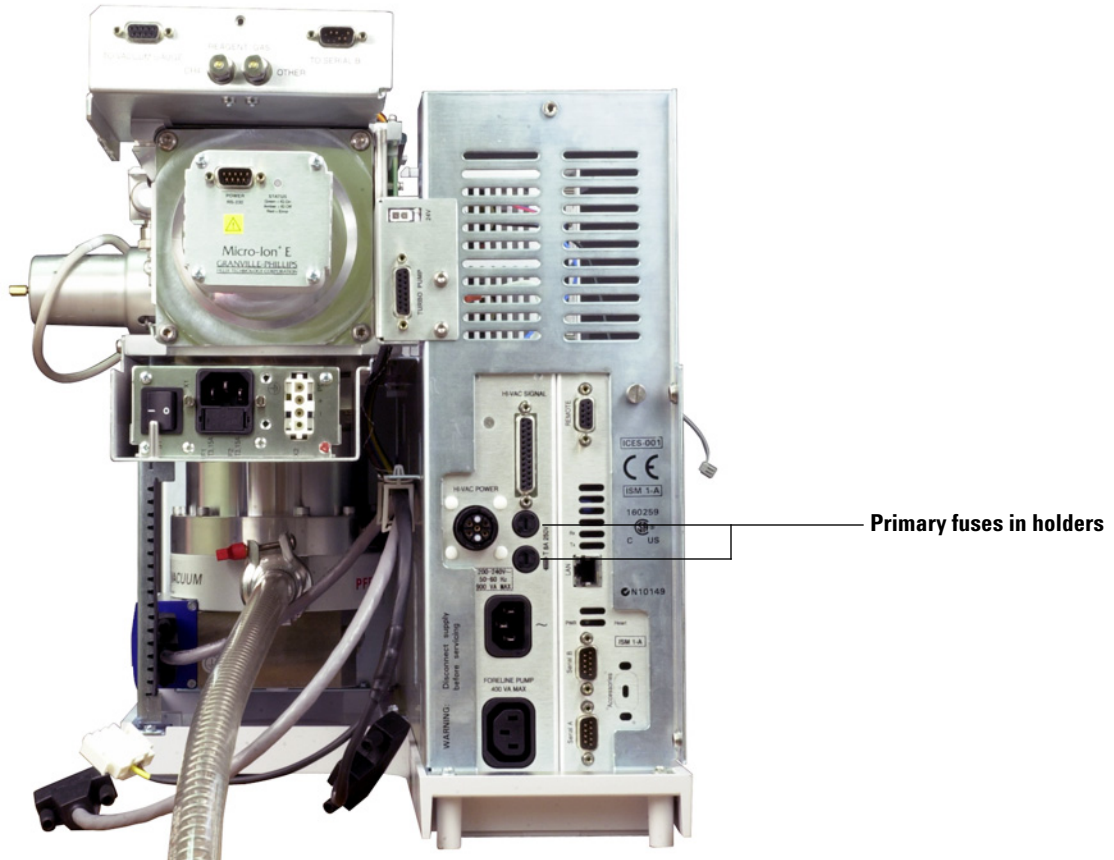
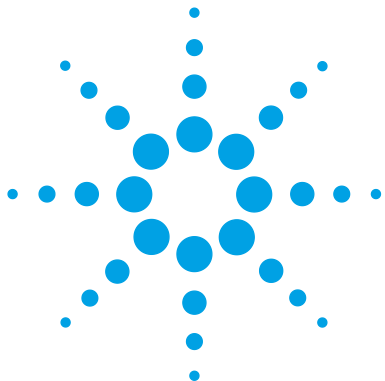

Figure 30 Primary fuses (turbo model shown)

- 6 Repeat steps 3 through 6 for the other fuse. Always replace both fuses.
- 7 Reconnect the MSD power cord to the electrical outlet.
- 8 Pump down the MSD.



5 CI Maintenance

- To Clean the CI Ion Source 164
- To Minimize Foreline Pump Damage from Ammonia (Standard Pump) 166
- To Replace the Methane/Isobutane Gas Purifier 167
- To Clean the Reagent Gas Supply Lines 168
- To Refill the CI Calibrant Vial 169

This chapter describes maintenance procedures and requirements that are unique to 5975 Series MSDs equipped with the Chemical Ionization hardware.



To Clean the CI Ion Source

The CI ion source has slightly different cleaning requirements than the EI ion source. See the video clip in the 5975 Series MSD User Information DVD.

Frequency of cleaning

Because the CI ion source operates at much higher pressures than the EI ion source, it will probably require more frequent cleaning than the EI ion source. Cleaning of the source is not a scheduled maintenance procedure. The source should be cleaned whenever there are performance anomalies that are associated with a dirty ion source. See “CI Troubleshooting” on page 57 for symptoms that indicate a dirty ion source.

Visual appearance is not an accurate guide to cleanliness of the CI ion source. The CI ion source can show little or no discoloration yet still need cleaning. Let analytical performance be your guide.

Procedure

Cleaning the CI ion source (Figure 31) is very similar to cleaning the EI ion source. Use the cleaning procedure in “To clean the EI ion source” on page 135 with the following exceptions:

- The CI ion source may not look dirty but deposits left by chemical ionization are very difficult to remove. Clean the CI ion source thoroughly.
- Use a round wooden toothpick to gently clean out the electron entrance hole in the source body and the ion exit hole in the drawout plate.
- Do not use halogenated solvents. Use hexane for the final rinse.

CAUTION

Do not use halogenated solvents to clean the CI ion source.

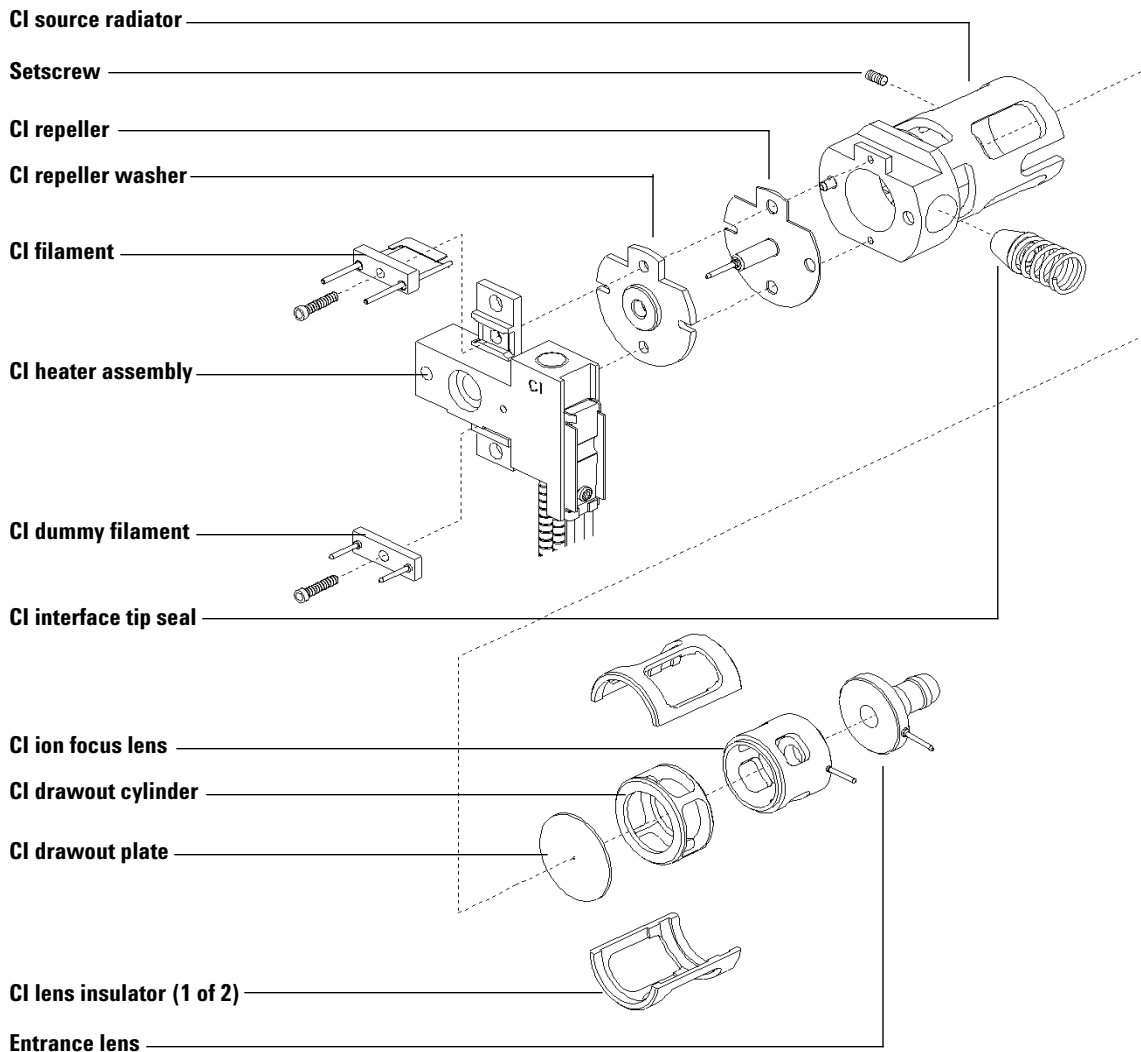

Figure 31 Exploded view of the CI ion source

To Minimize Foreline Pump Damage from Ammonia (Standard Pump)

Air ballasting for an hour every day removes most of the ammonia from the pump oil. This will greatly increase the life of the pump.

CAUTION

Only perform this procedure if the pump is at normal operating temperature. The water vapor in air can cause condensation of the ammonia at the ballast valve if the pump is cold.

Procedure

- 1 Turn the ballast valve on the foreline pump (Figure 32) until the 1s are aligned. The sound of the pump will get much louder.



Figure 32 Minimizing ammonia damage

- 2 Leave the ballast valve open for one hour. You can continue to run samples while the pump is ballasting.
- 3 Close the ballast valve by aligning the 0s. Leaving the ballast valve open all the time will result in loss of pump oil and damage to the pump.

CAUTION

Always purge the flow module with methane after flowing ammonia. The use of ammonia reagent gas also requires that the foreline pump oil be changed every 2 to 3 months instead of the usual 6 months.

To Replace the Methane/Isobutane Gas Purifier

Materials needed

- Methane/Isobutane gas purifier (G1999-80410)
- Front ferrule for 1/8-inch tubing (5180-4110)
- Rear ferrule for 1/8-inch tubing (5180-4116)
- Tubing cutter (8710-1709)

The methane/isobutane gas purifier needs to be replaced after four tanks of reagent gas. This frequency may vary depending on purity of the gas and care taken in uncapping and installing the gas purifier. A large leak upstream from the gas purifier can quickly exhaust the reduced metal of the oxygen and moisture traps.

Procedure

- 1 To install the methane/isobutane gas purifier, follow the instructions on the label for installation and replacement intervals.

CAUTION

Do not remove the caps until you are ready to install the gas purifier. Only remove the caps in the gas flow to prevent contamination by air.

WARNING

Methane is flammable. Extinguish all flames in the area before turning on gas flow.

- 2 Disconnect the fittings on the old filter.
- 3 Remove the ferrules from the tubing at the outlet of the gas purifier. Using the tubing cutter, cut off the end of the tubing with the ferrules.
- 4 Install the new filter.
- 5 Purge the new filter.
- 6 Cap the old filter and prepare it to be sent for regeneration. See the instructions on the label.

To Clean the Reagent Gas Supply Lines

Materials needed

- Clean, dry nitrogen
- Heat gun
- Tubing cutter (8710-1709)

Procedure

If the reagent gas lines become contaminated, they can be cleaned.

- 1 Disconnect the reagent gas tubing from the gas supply, the gas purifier, and the MSD.
- 2 Cap the gas purifier following the instructions on the label.
- 3 Connect one end of the tubing to a supply of clean, dry nitrogen and turn on gas flow.
- 4 Use the heat gun to warm the tubing, starting at the supply end and working your way to the free end.
- 5 Repeat for any other pieces of tubing that need to be cleaned.
- 6 Reconnect the tubing to the gas supply, gas purifier, and MSD. Follow the instructions on the gas purifier label.

WARNING

Do not heat the gas tubing when reagent gas is flowing.

CAUTION

Do not put liquids into the tubing. Do not heat the tubing when it is connected to the MSD.

To Refill the CI Calibrant Vial

Materials needed

- PFDTD calibrant (8500-8510)

Procedure

- 1 Set the reagent gas flow to **Gas Off**.
- 2 Vent the MSD.
- 3 Remove the capillary column from the GC/MSD interface.
- 4 Pull the MSD away from the GC to expose the calibration vial and valve. See [page 103](#).
- 5 Loosen the collar holding the calibration vial in place. Do not remove the collar.
- 6 Remove the calibrant vial. See [Figure 33](#).

CAUTION

Do **not** rinse the vial with any solvents. **Never** expose the inside of the vial to chlorinated solvents or isopropyl alcohol or water — this will result in severe loss of CI sensitivity.

- 7 Fill the vial no higher than the bottom of the internal tube with fresh PFDTD calibrant (8500-8510).
- 8 Replace the vial and tighten the collar.
- 9 Reposition the MSD next to the GC. See [page 105](#).
- 10 Reinstall the capillary column.
- 11 Pump down the MSD.
- 12 Purge the calibration valve. See [page 111](#).

CAUTION

After removing the calibrant vial, you **must** purge the calibration valve. Failure to do so will result in severe contamination of the ion source and damage to the filament and electron multiplier.

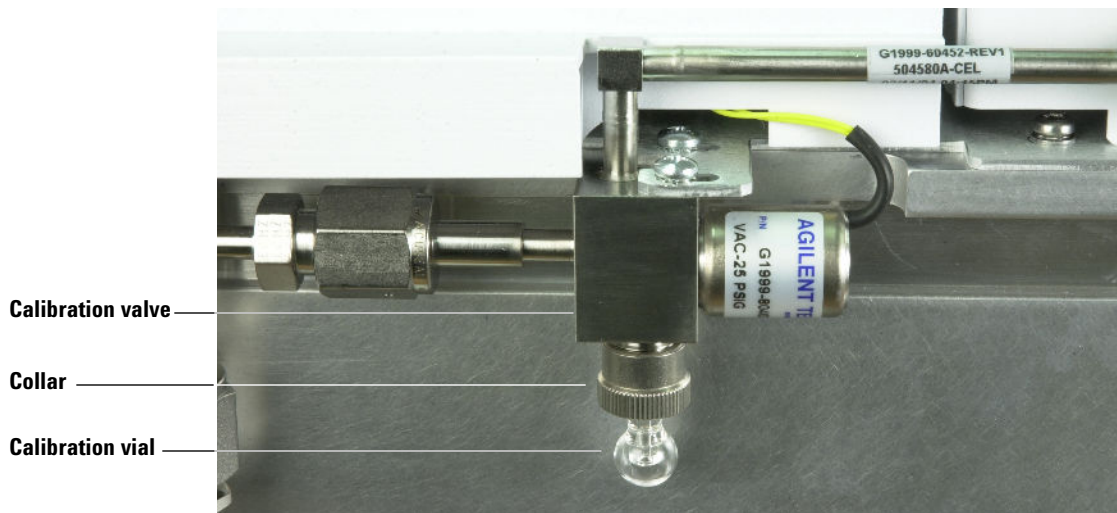
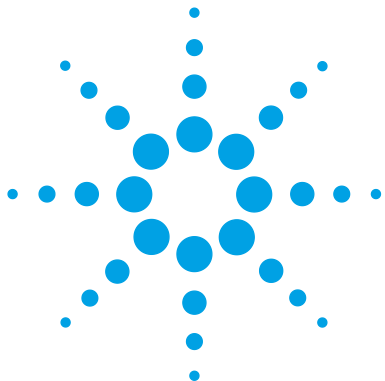

Figure 33 CI calibration valve and vial



6 Vacuum System

Overview	172
Vacuum System Components	173
Common Vacuum System Problems	174
Foreline Pump	175
High Vacuum Pump	178
Analyzer Chamber	179
Side Plate	180
Vacuum Seals	182
Face seals	182
KF (NW) seals	182
Compression seals	183
High voltage feedthrough seal	183
Foreline Gauge	184
Diffusion Pump and Fan	185
Turbo Pump and Fan	191
Calibration Valves and Vent Valve	192
Micro-Ion Vacuum Gauge	195

This chapter describes components of the MSD vacuum system.



Overview

The vacuum system creates the high vacuum (low pressure) required for the MSD to operate. Without the vacuum, the molecular mean free path would be very short and ions would collide with air molecules before they could reach the detector. Operation at high pressures also would damage analyzer components.

The 5975 Series MSDs use two vacuum pumps to obtain the vacuum levels needed. One of two foreline pumps (standard or dry) creates a low vacuum, then a high vacuum pump engages to create the vacuum needed for operation. The 5975 Series MSD uses one of three kinds of high vacuum pumps: a diffusion pump or one of two turbomolecular (turbo) pumps. The pump type determines the maximum column flow supported by the MSD. See [Table 9](#).

Table 9 Recommended maximum flow rates per high vacuum pump

Model number	Description	Maximum recommended column flow
G3170A G3175A	Diffusion pump, EI	1.5 mL/min
G3171A G3176A	Standard turbo pump, EI	2.0 mL/min
G3172A	Performance turbo pump, EI	4.0 mL/min
G3174A	Performance turbo pump, EI, PCI, NCI	4.0 mL/min

Most vacuum system operation is automated. Operator interaction is through the data system or control panel. Monitor the vacuum system through the data system and/or local control panel.

Vacuum System Components

The parts of the vacuum system are identified in [Figure 34](#).

- Foreline (rough) pump
- High vacuum pump (diffusion or turbo pump)
- Analyzer chamber
- Side plate (analyzer door), and front and rear end plates
- Vacuum seals
- Calibration valve(s) and vent valve
- Vacuum control electronics
- Vacuum gauges and gauge control electronics

Each of these is discussed in more detail in this chapter.

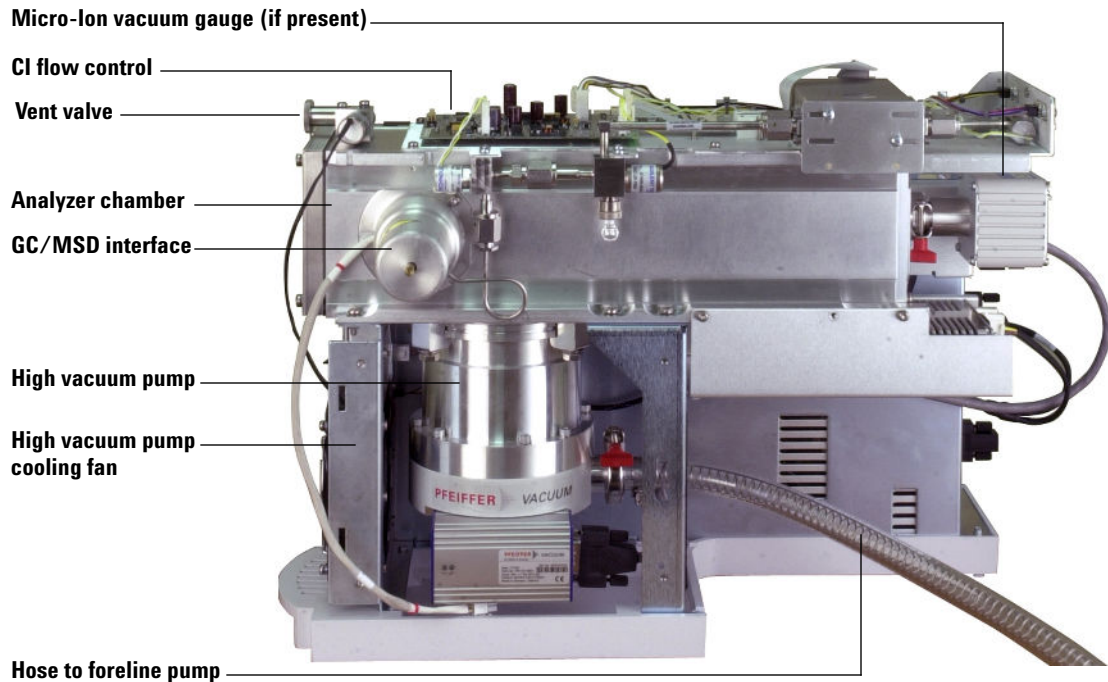

Figure 34 Example vacuum system components (MSD with turbo pump shown)

Common Vacuum System Problems

Air leak symptoms

The most common problems associated with any vacuum system are air leaks. Symptoms of air leaks include:

- Loud gurgling noise from the foreline pump (very large leak.)
- Inability of the turbo pump to reach 95% speed
- High foreline pressure in diffusion pump MSDs
- Higher than normal high vacuum gauge controller readings

The 5975 Series MSD will *not* pump down successfully unless you press on the side plate (analyzer door) when you turn on the MSD power. Continue to press until the sound from the foreline pump becomes quieter.

Pumpdown failure shutdown

The system will shut down both the high vacuum and the foreline pump if the system fails to pump down correctly. Two conditions that trigger shutdown are:

- For diffusion pump MSDs, shutdown occurs if the foreline pressure is above 300 mTorr after 7 minutes.
- Turbo pump MSDs speed below 80% after 7 minutes.

This is usually because of a **large** air leak: either the side plate has not sealed correctly or the vent valve is still open. This feature helps prevent the foreline pump from sucking air through the system, which can damage the analyzer and pump.

To restart the MSD, find and correct the air leak, then switch the power off and on. Be sure to press on the side plate when turning on the MSD power to ensure a good seal.

Foreline Pump

The foreline pump (Figure 35) reduces the pressure in the analyzer chamber so the high vacuum pump can operate. It also pumps away the gas load from the high vacuum pump. The foreline pump is connected to the high vacuum pump by a 130-cm hose called the foreline hose.

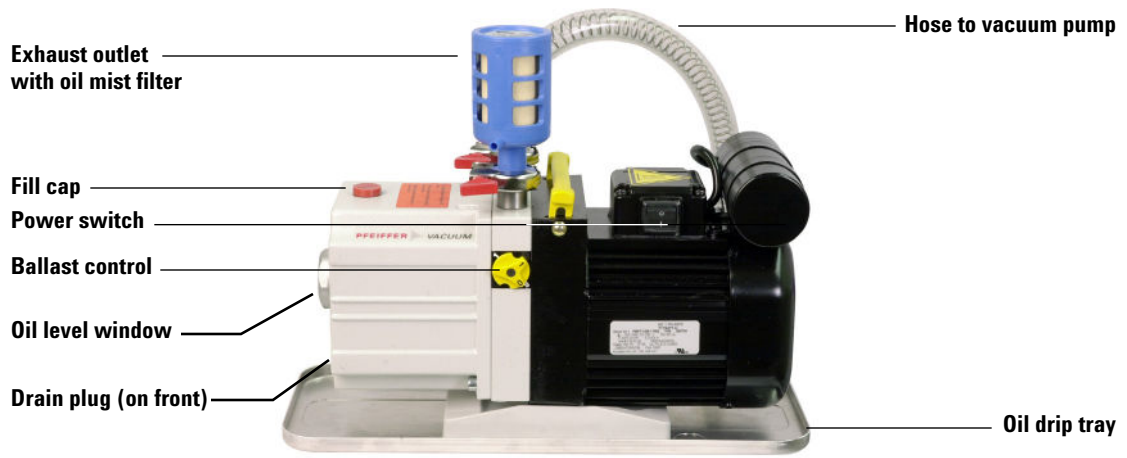

Standard pump (shown without safety cage)

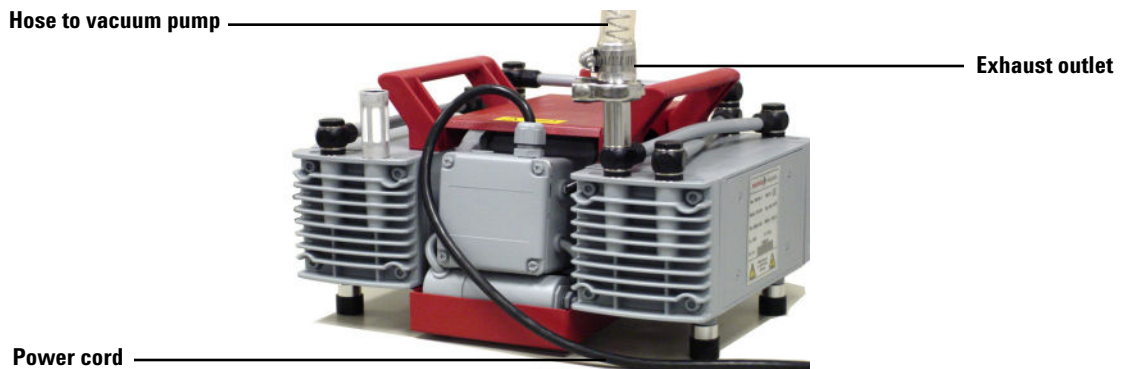

Dry pump (shown without cover)

Figure 35 The standard foreline pump

The standard foreline pump is a two-stage rotary-vane pump. An optional dry pump is also available. The pump turns on when the MSD power is turned on. The foreline pump has a built-in antisuckback valve to help prevent backstreaming in the event of a power failure.

The foreline pump can be placed under the analyzer chamber at the rear of the MSD (with the exhaust outlet to the rear) or on the floor below the MSD.

An oil trap (not shown) is available for the standard pump that can be used to filter pump oil out of the foreline pump exhaust. This trap stops *only* pump oil. Do not use the trap if you are analyzing toxic chemicals or using toxic solvents or if you have a CI MSD. Instead, install an 11-mm id hose to remove the exhaust from your lab.

WARNING

The oil trap supplied with the standard foreline pump stops only foreline pump oil. It does not trap or filter out toxic chemicals. If you are using toxic solvents or analyzing toxic chemicals, remove the oil trap. Do not use the trap if you have a CI MSD. Install a hose to take the foreline pump exhaust outside or to a fume hood.

CAUTION

Do not place the foreline pump near any equipment that is sensitive to vibration.

CAUTION

The ballast control knob controls the amount of air allowed into the pump. Keep the ballast control closed (fully clockwise) at all times, except when ballasting the pump.

A window (sight glass) in the front of the standard foreline pump shows the level of the foreline pump oil. There are two marks next to the window. The level of the pump oil should never be above the upper mark or below the lower mark. If the level of pump oil is near the lower mark, add foreline pump oil.

The oil pan under the foreline pump can be a fire hazard (standard pump)

Oily rags, paper towels, and similar absorbents in the oil pan could ignite and damage the pump and other parts of the MSD.

WARNING

Combustible materials (or flammable/non-flammable wicking material) placed under, over, or around the foreline (roughing) pump constitutes a fire hazard. Keep the pan clean, but do not leave absorbent material such as paper towels in it.

High Vacuum Pump

Diffusion pump system

The diffusion pump supports a maximum flow rate into the MSD of 1.5 mL/min. The diffusion pump uses baffling to prevent vapor from migrating into the analyzer chamber. Foreline pressure is monitored by the foreline gauge. The AC board controls the diffusion pump heater.

Turbo pump system

The 5975 Series MSD can have one of two turbo pumps. Both pumps are referred to as turbo pumps.

Both turbo pumps have screens to keep debris out of the pump, but no baffle is necessary. Pump speed is controlled by the turbo controller; there is no foreline gauge.

Analyzer Chamber

The analyzer chamber (Figure 36) is where the analyzer operates. The manifold is extruded and machined from an aluminum alloy. Large openings in the side, front, and rear of the analyzer chamber are closed by plates. O-rings provide the seals between the plates and the manifold. Ports in the manifold and the plates provide attachment points for the Micro-Ion vacuum gauge, calibration valve, vent valve, GC/MSD interface, and high vacuum pump.

Diffusion pump version

The diffusion pump attaches with a KF50 seal to a baffle adapter that is clamped to the bottom of the manifold. A vapor baffle helps prevent migration of pump fluid vapor into the manifold. Cooling fins on the bottom of the manifold keep the baffle cool so the vapor will condense on it.

Turbo pump version

The turbo pump and the mounting bracket for the turbo controller are clamped directly to the manifold.

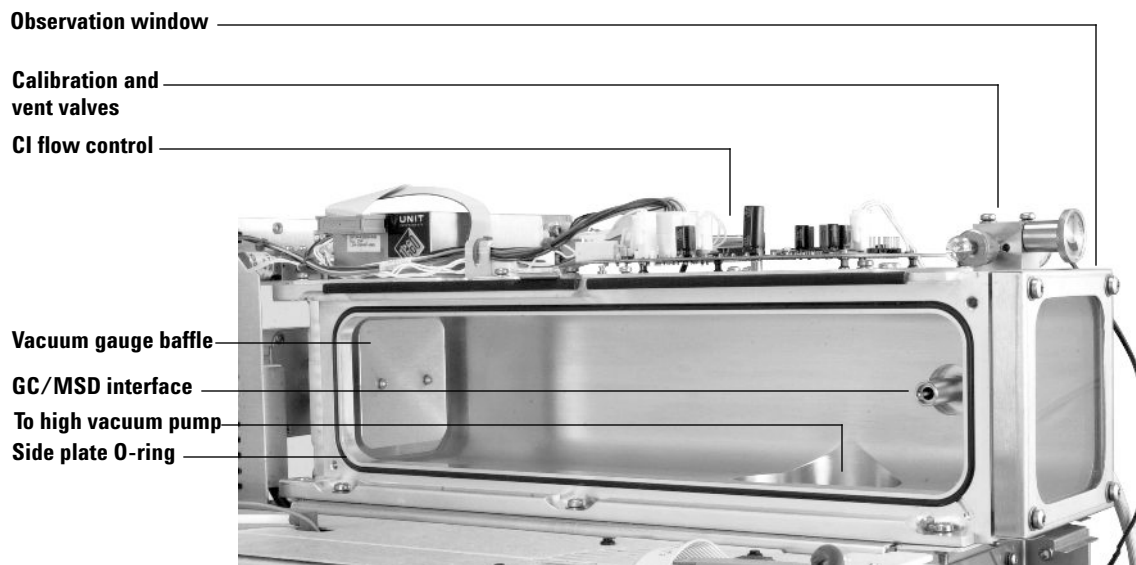

Figure 36 Analyzer chamber

Side Plate

The side plate (Figure 37) covers the large opening in the side of the analyzer chamber. It is attached to the manifold with a hinge. The analyzer assembly is attached to the side plate inside the analyzer chamber. The hinge allows the side plate to swing away from the manifold for easy access to the analyzer.

Several electrical feedthroughs are built into the side plate. Wires connect the feedthroughs to analyzer components. The electronic side board is mounted on the atmospheric side of the side plate.

Thumbscrews are located at each end of the side plate.

CAUTION

Fasten both side plate thumbscrews for shipping or storage only. For normal operation, both thumbscrews should be loose. For operation with hydrogen carrier gas, or with flammable or explosive CI reagent gases, the front thumbscrew should be fastened just finger-tight. Overtightening will warp the side plate and cause air leaks. Do not use a tool to tighten the side plate thumbscrews.

CAUTION

When you turn on the power to pump down the MSD, be sure to press on the side board to ensure a good seal.

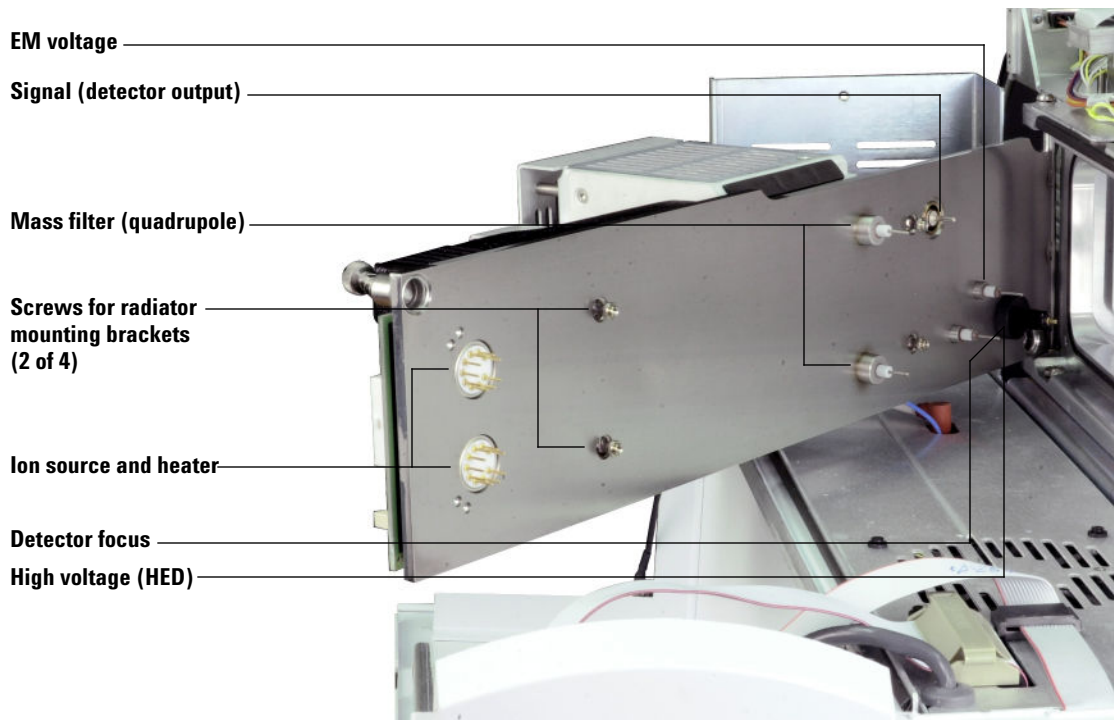

Figure 37 Side plate feedthroughs

Vacuum Seals

Vacuum seals are shown in [Figure 38](#).

Several types of Viton elastomer O-ring seals are used to prevent air leaks into the analyzer chamber. All these O-rings, and the surfaces to which they seal, must be kept clean and protected from nicks and scratches. A single hair, piece of lint, or scratch can produce a serious vacuum leak. Two of the O-rings are *lightly* lubricated with Apiezon-L vacuum grease: the side plate O-ring and the vent valve O-ring.

Face seals

A face seal is an O-ring that fits in a shallow groove. The sealing surface is usually a flat plate. The manifold side plate and end plate O-rings fit into grooves around the large openings in the analyzer chamber. The side plate swings into place against the side plate O-ring, and must be held in place when the MSD is turned on for pump down to assure a good seal.

The front and rear end plates are screwed onto the manifold and should not need to be removed. The GC/MSD interface fastens to the manifold with three screws.

The calibration valve assembly is fastened onto the front end plate by two screws. The vent valve knob threads into the front end plate. Small O-rings in grooves in the front end plate provide vacuum seals.

The diffusion pump baffle adapter has a groove for its O-ring. The baffle adapter is clamped to the manifold with four claw grips.

KF (NW) seals

Most of the seals for the high vacuum pumps, foreline gauge, and foreline pump are KF seals. KF seals have an O-ring supported by a centering ring. The centering ring can be either on the inside or the outside of the O-ring. The clamp presses two flanges against the O-ring, making a seal. KF clamps must not be overtightened.

Compression seals

A compression fitting consists of a threaded fitting on the analyzer chamber and a threaded collar with a ferrule and O-ring. A cylindrical part fits inside the collar. Tightening the collar presses the ferrule, compressing the O-ring around the part. The calibration vials use compression seals.

High voltage feedthrough seal

The high voltage (HED) feedthrough seal is an O-ring that is compressed against the side plate by a threaded collar.

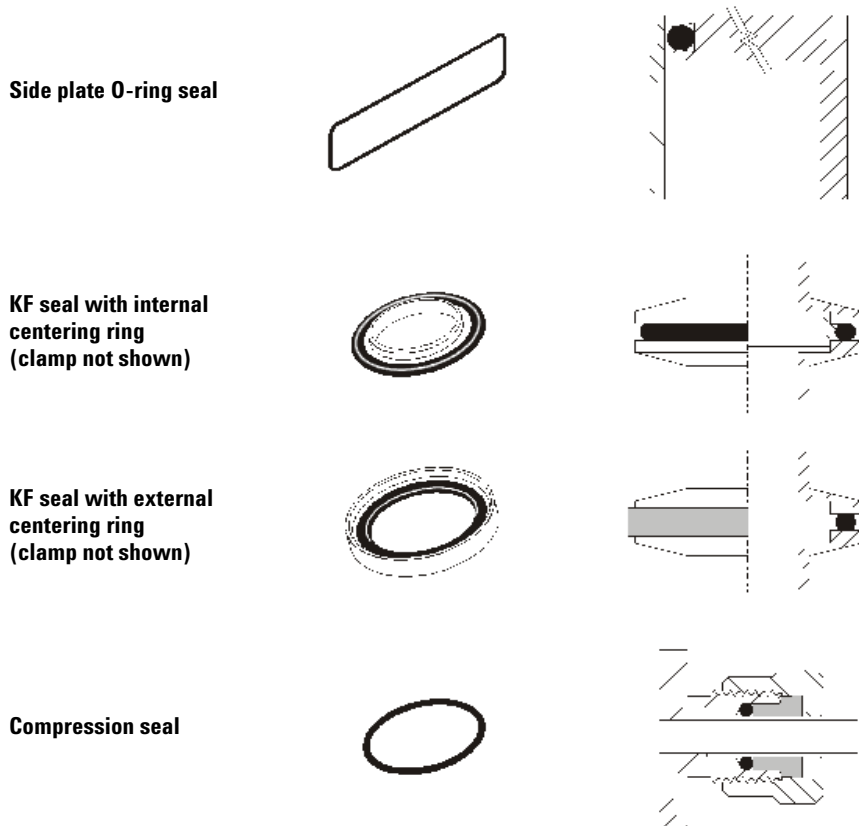

Figure 38 Vacuum seals

Foreline Gauge

The foreline gauge monitors the pressure (vacuum) at the exit of the diffusion pump. The primary function of the foreline gauge is diffusion pump control. When the foreline pump has reduced the pressure in the analyzer chamber to below 300 mTorr (0.3 Torr), the diffusion pump is automatically switched on. If the foreline pressure rises above 400 mTorr (0.4 Torr), the AC board switches off the diffusion pump heater and the analyzer electronics.

Monitor the foreline pressure from the data system or the LCP.

The foreline gauge is used only with diffusion pump MSDs.

Diffusion Pump and Fan

The diffusion pump in the MSD is an air-cooled vapor diffusion pump with 90 L/s capacity. It mounts with a KF50 fitting to a baffle adapter clamped to the bottom of the analyzer chamber.

The diffusion pump has a cylindrical body surrounded by fins to help dissipate heat. Its inlet is open to the interior of the analyzer chamber, through the adapter and baffle. A structure called the stack is located at the center of the pump body. An electric heater is located at the bottom of the stack. See [Figure 39](#).

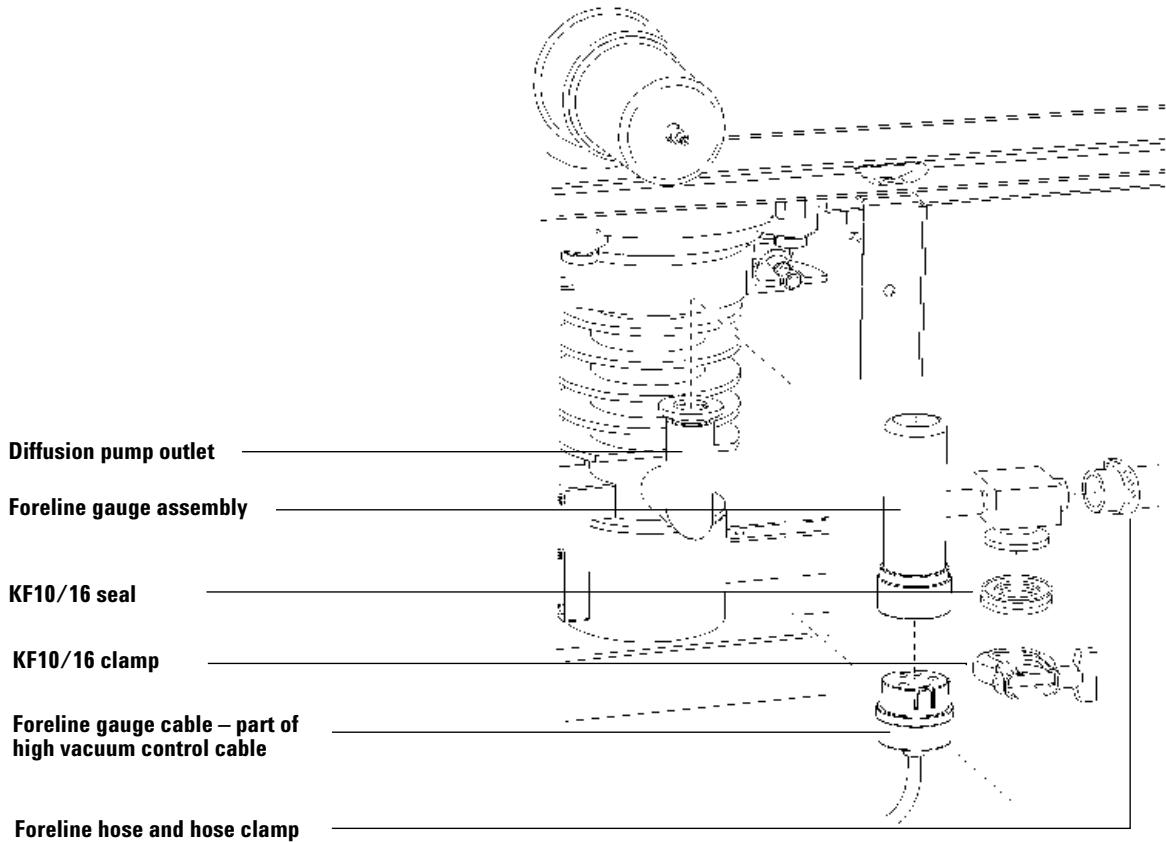

Figure 39 Diffusion pump parts

The diffusion pump transports gas by momentum transfer. The heater boils a special fluid (a polyphenyl ether) inside the stack. As the vapor pressure increases, the pump fluid vapor is forced out and downward through nozzles in the stack. The vapor forced out of these nozzles strikes the gas molecules that are present. This forces the gas molecules down toward the outlet near the bottom of the pump. Another nozzle in the stack points directly at the outlet and forces the gas molecules out. The vapor condenses on the sides of the pump and the liquid drains down to the bottom. The liquid is boiled again and is reused continuously.

A cooling fan is located between the diffusion pump and the front cover of the MSD. The fan draws air through the cover and blows it over the pump. Without this cooling, the pump fluid vapor would not condense correctly, but would diffuse into the analyzer chamber.

The foreline pump is connected by the foreline hose to the outlet of the diffusion pump. It removes the gas molecules that reach the outlet.

The diffusion pump operation is controlled by the AC board. The AC board turns on the diffusion pump heater automatically as soon as the foreline pump lowers the pressure in the analyzer chamber below approximately 300 mTorr (0.3 Torr). Until the foreline pressure drops below 300 mTorr, the diffusion pump heater will not turn on. If the pressure does not drop below 300 mTorr within 7 minutes of turning the MSD on, the foreline pump will shut off. During operation, if the foreline pressure rises above 400 mTorr, the diffusion pump heater will turn off. The AC board allows the analyzer electronics to turn on when the diffusion pump is hot.

The diffusion pump typically maintains an indicated pressure below 1.0×10^{-4} Torr for GC helium carrier gas flows up to 2 mL/min. High vacuum (manifold) pressure can only be measured if your MSD is equipped with the optional gauge controller.

The small size of the diffusion pump allows it to heat up and cool down quickly. This simplifies pumpdown and venting. From initial power-on, the system can pump down to operating pressure in approximately 15 minutes. If the power fails, the diffusion pump fluid stops boiling before the analyzer chamber pressure begins to rise significantly. This helps prevent back diffusion of pump fluid into the analyzer chamber. Your data system has pumpdown and venting programs to guide you through these procedures. Follow the instruction carefully.

Two thermal switches monitor diffusion pump operational readiness. See [Table 10](#).

Table 10 Diffusion pump thermal switches

Thermal switch	Too cold	Too hot
Normal state	Normally open	Normally closed

Table 10 Diffusion pump thermal switches (continued)

Changes at	170 °C rising; 140 °C falling	365 °C rising
Function	Keeps analyzer turned off until the pump is hot enough to for adequate vacuum. Prevents analyzer damage	Shuts off diffusion pump and analyzer if the pump overheats. Prevents damage to the pump and analyzer.
Message	The high vacuum pump is not ready	Difficulty with the high vacuum pump
What it means	Normal during pumpdown	Always indicates a problem
What to do	Wait for pump to heat up	Check the level and conditions of the fluid. Make sure pump is cool, and power-cycle MSD to reset.

Check the condition and level of the diffusion pump fluid through the window (sight glass) near the base of the front of the pump. See [Figure 40](#). If the level drops below the appropriate marker (there are separate ranges for hot and cold conditions) or if the fluid turns dark brown or black, replace the fluid. Otherwise, replace the fluid once a year.

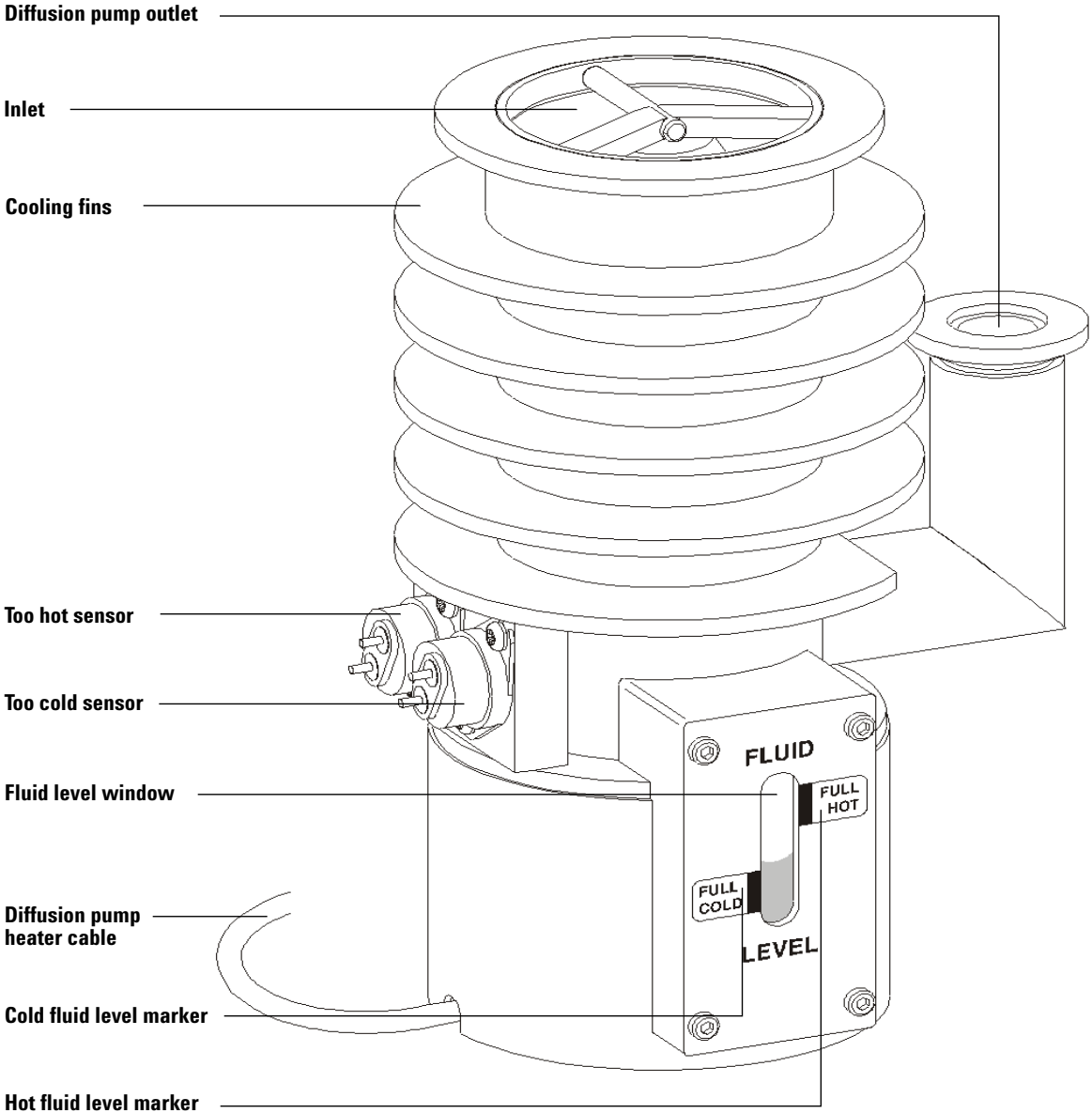

Figure 40 The diffusion pump

Diffusion pump fluid that is exposed to air at operating temperature will break down and turn dark brown or black. This reaction is called cracking. Cracked pump fluid gives two symptoms: higher manifold pressure and high background with a large peak at m/z 446.

See also

- *“Maintaining the Vacuum System” on page 89.*
- *The troubleshooting sections of the MSD ChemStation online help.*

Turbo Pump and Fan

The turbo pump is clamped directly to the bottom of the analyzer chamber.

The turbo pump has a cylindrical body with its inlet open to the interior of the analyzer chamber. Inside the pump body is a central shaft or cylinder. Sets of small blades (airfoils) radiate from the central shaft. The shaft spins at up to 60,000 revolutions per minute (rpm) in the performance turbo pump, and 90,000 rpm in the standard turbo pump.

Turbo pumps move gas by momentum transfer. The turbine blades are angled so that when they strike a gas molecule it is deflected downward. Each set of blades pushes the gas molecules further down toward the pump outlet. The foreline pump is connected by a hose to the outlet of the turbo pump. It removes the gas molecules that reach the outlet.

A controller regulates current to the pump and monitors pump motor speed and temperature. A cooling fan is located between the turbo pump and the front panel of the MSD. The fan draws air from outside the MSD and blows it over the pump.

The turbo pump turns on automatically when the MSD power is switched on. The system allows the analyzer to be turned on when the turbo pump is greater than 80% speed, but the pump normally operates at 100% speed. Turbo pump MSDs typically maintain an indicated pressure below 8×10^{-5} Torr for helium column flows up to 4 mL/minute for the performance turbo pump, and up to 2 mL/minute for the standard turbo pump. Pressure (vacuum) can only be measured if your MSD is equipped with the optional gauge controller.

The turbo pump spins up (starts) and spins down (stops) quickly. This simplifies pumpdown and venting. From initial power-on, the system can pump down to operating pressure in 5 to 10 minutes.

See Also

- *To pump down the MSD*
- *To vent the MSD*
- *Turbo pump control, page 221.*

Calibration Valves and Vent Valve

Calibration valves

A calibration valve (Figure 41) is an electromechanical valve with a vial to hold the tuning compound. When a calibration valve is opened, tuning compound in the vial diffuses into the ion source. EI MSDs have one calibration valve; CI MSDs have a second calibration valve for the CI tuning compound. The valves are controlled by the MSD ChemStation.

EI calibration valve

The EI calibration valve is held onto the top of the analyzer chamber by two screws. A small O-ring provides a face seal.

The diffusion pump and the standard turbo pump MSD have a calibration valve with less restriction than that in the performance turbo MSD; this allows the correct diffusion of calibrant for each vacuum system.

Perfluorotributylamine (PFTBA) is the most commonly used tuning compound for EI operation. PFTBA is required for automatic tuning of the MSD. Other compounds can be used for manual tuning.

CI calibration valve

The CI tuning compound is perfluoro-5,8-dimethyl-3,6,9-trioxidodecane (PFDTD). The CI calibration valve is part of the reagent gas flow control module. It is controlled by the ChemStation software. It opens automatically during CI autotune or manual tuning, allowing PFDTD to diffuse through the GC/MSD interface and into the ion source.

Vent valve

The vent valve knob (Figure 42) screws into a threaded port in the front of the calibration valve. An O-ring is compressed between the knob and the valve to form a seal. The threaded end of the knob has an air passage inside it, allowing air to flow into the manifold when the knob is partially unscrewed. If you turn the knob too far, the O-ring can come out of its slot.

EI CALIBRATION
above analyzer window

EI calibration vial

Vent valve knob

EI calibration valve



CI CALIBRATION
right side of MSD

CI calibration valve

CI calibration vial

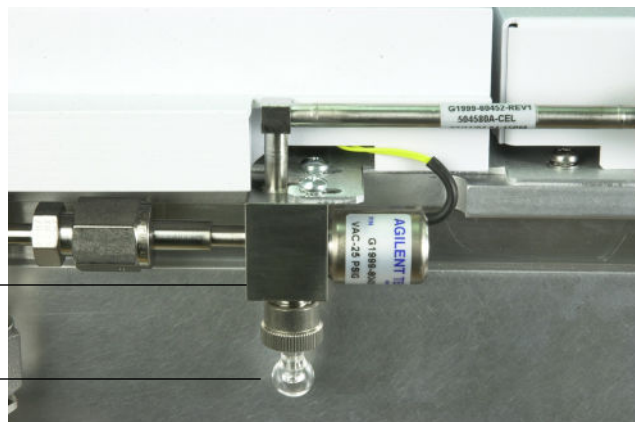

Figure 41 Calibration valves

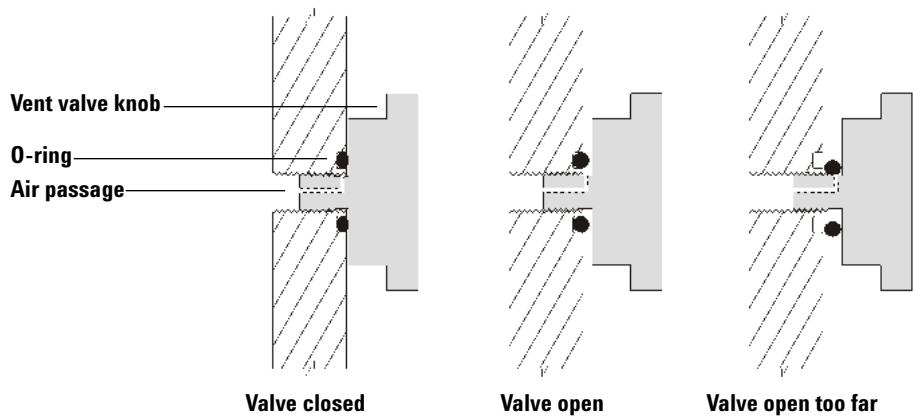

Figure 42 Vent valve

Micro-Ion Vacuum Gauge

The G3397A Micro-Ion vacuum gauge is standard on CI MSDs and optional on EI MSDs. It consists of the sensing element (an ionization-type gauge) and the necessary electronics to support it. Both parts are mounted in a single package.

The ionization gauge creates a current when energized electrons collide with gas molecules. The electronics provide the voltages required, measure the current produced, and produce an output signal that is used by the MSD software.

The Micro-Ion vacuum gauge mounts on the end of the analyzer chamber and is open to it. This allows you to monitor chamber pressure in daily operation and in troubleshooting.

The gauge is calibrated for nitrogen (N_2). The carrier gas is usually helium, which does not ionize as readily as nitrogen. Therefore, the *indicated* pressure for helium is approximately six times lower than the absolute pressure. For example, a reading of 2.0×10^{-5} Torr versus an absolute pressure of 1.2×10^{-4} Torr.

In a CI MSD, the indicated pressure reflects the contribution of both the carrier gas and the reagent gas. The distinction between indicated and absolute pressure is not important for normal operation of the MSD. Of greater concern are changes in pressure from hour to hour or day to day. These changes can indicate air leaks or other problems with the vacuum system. All the pressures listed in this manual are indicated pressures for helium carrier gas. The gauge controller setpoints are also indicated pressures.

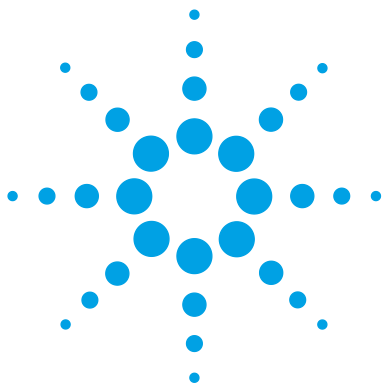

7 Analyzer

Overview	198
El Ion Source	200
CI Ion Source	202
Filaments	204
Filament selection	204
Emission current	204
Electron energy	204
Filament care	205
Other Source Elements	206
Magnet	206
Repeller	206
Drawout plate and cylinder	206
Ion focus	206
Entrance lens	207
Quadrupole Mass Filter	208
AMU gain	209
AMU offset	209
219 width	209
DC polarity	210
Mass (axis) gain	210
Mass (axis) offset	210
Quadrupole maintenance	210
Detector	211
Detector ion focus	211
High energy dynode	211
EM horn	211
Analyzer Heaters and Radiators	213

This chapter describes the parts of the analyzer.



Overview

The analyzer (Figure 43) is the heart of the MSD. It ionizes the sample, filters the ions, and detects them. The sample components exiting the GC column flow into the ion source. In the ion source, the sample molecules are ionized and fragmented. The resulting ions are repelled from the ion source into the quadrupole mass filter. The mass filter allows selected ions to pass through the filter and strike the detector. The detector generates a signal current proportional to the number of ions striking it.

The analyzer is attached to the vacuum side of the side plate. The side plate is hinged for easy access. The ion source and the mass filter are independently heated. Each is mounted inside a radiator for correct heat distribution.

Each of the parts of the analyzer is discussed in the following material.

The analyzer has four basic components

The analyzer consists of the following components (Figure 43):

- Ion source
- Mass filter
- Detector
- Heaters and radiators

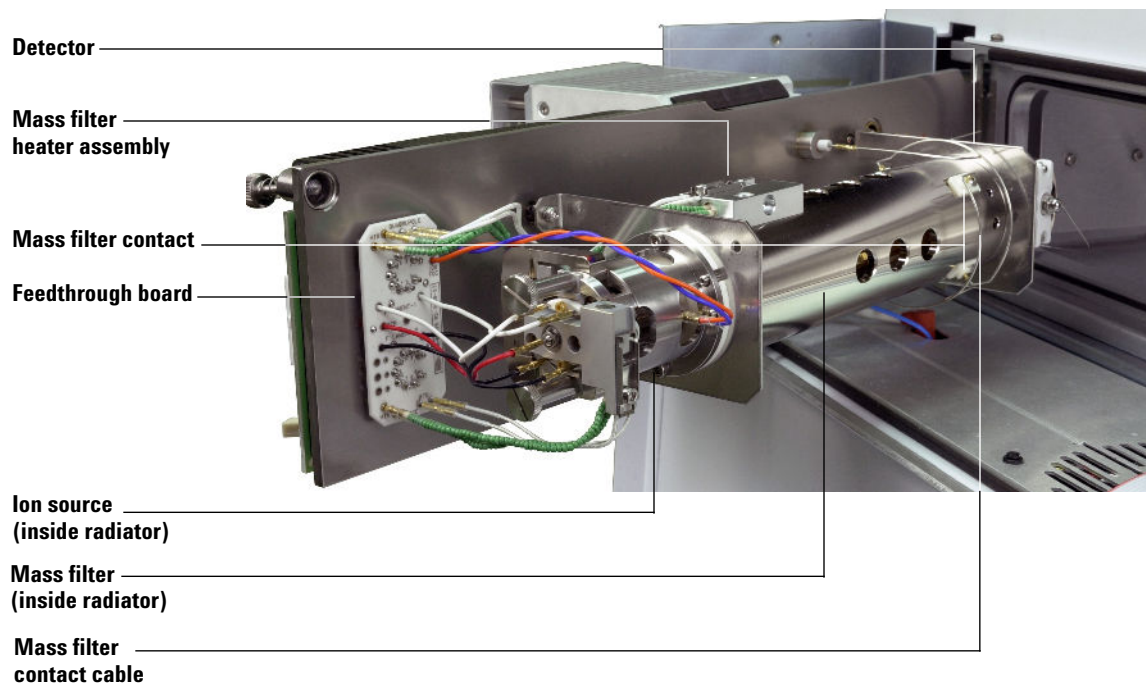

Figure 43 The analyzer

EI Ion Source

The EI ion source (Figure 44) operates by electron ionization. The sample enters the ion source from the GC/MSD interface. Electrons emitted by a filament enter the ionization chamber, guided by a magnetic field. The high-energy electrons interact with the sample molecules, ionizing and fragmenting them. The positive voltage on the repeller pushes the positive ions into the lens stack, where they pass through several electrostatic lenses. These lenses concentrate the ions into a tight beam, which is directed into the mass filter.

Ion source body

The ion source body (Figure 44) is a cylinder. It holds the other parts of the ion source, including the lens stack. With the repeller and the drawout plate, it forms the ionization chamber. The ionization chamber is the space where the ions are formed. Slots in the source body help the vacuum system to pump away carrier gas and un-ionized sample molecules or fragments.

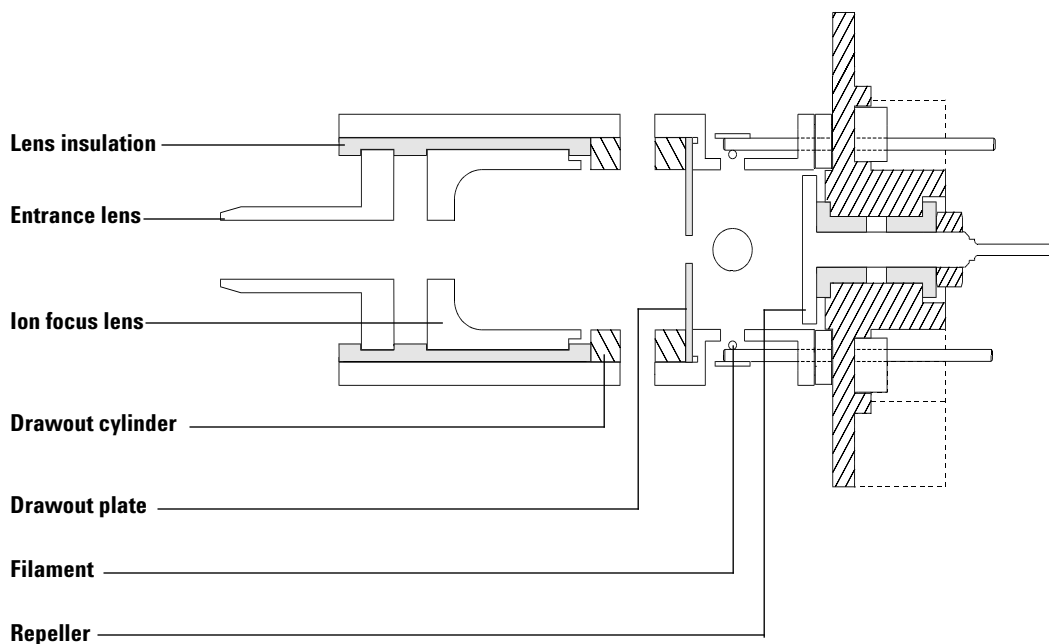

Figure 44 Ion source structure

The CI ion source is similar in design, but critical dimensions are different. Do not interchange parts.

CI Ion Source

The CI ion source (Figure 45 and Figure 46) is similar to the EI source, but only has one part in common with the EI source – the entrance lens. The single CI filament has a straight wire and a reflector. A “dummy” filament provides connections for the other wires.

The holes in the ion source (electron-entrance and ion-exit) are very small (0.5 mm), making it possible to pressurize the ionization chamber. Both the source body and the plate are at repeller potential, electrically isolated from the radiator and the CI interface tip. The seal for the interface tip ensures a leak-tight seal and electrical isolation between the CI interface and ion source.

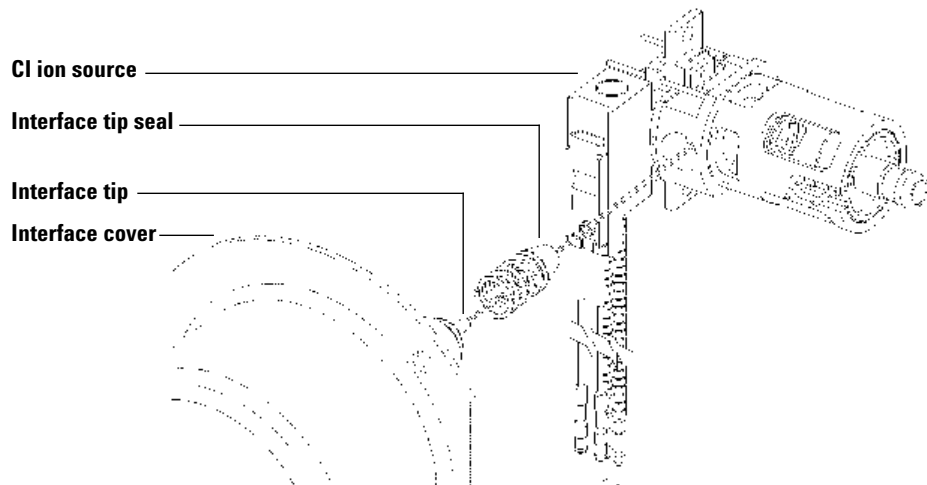

Figure 45 CI ion source tip seal

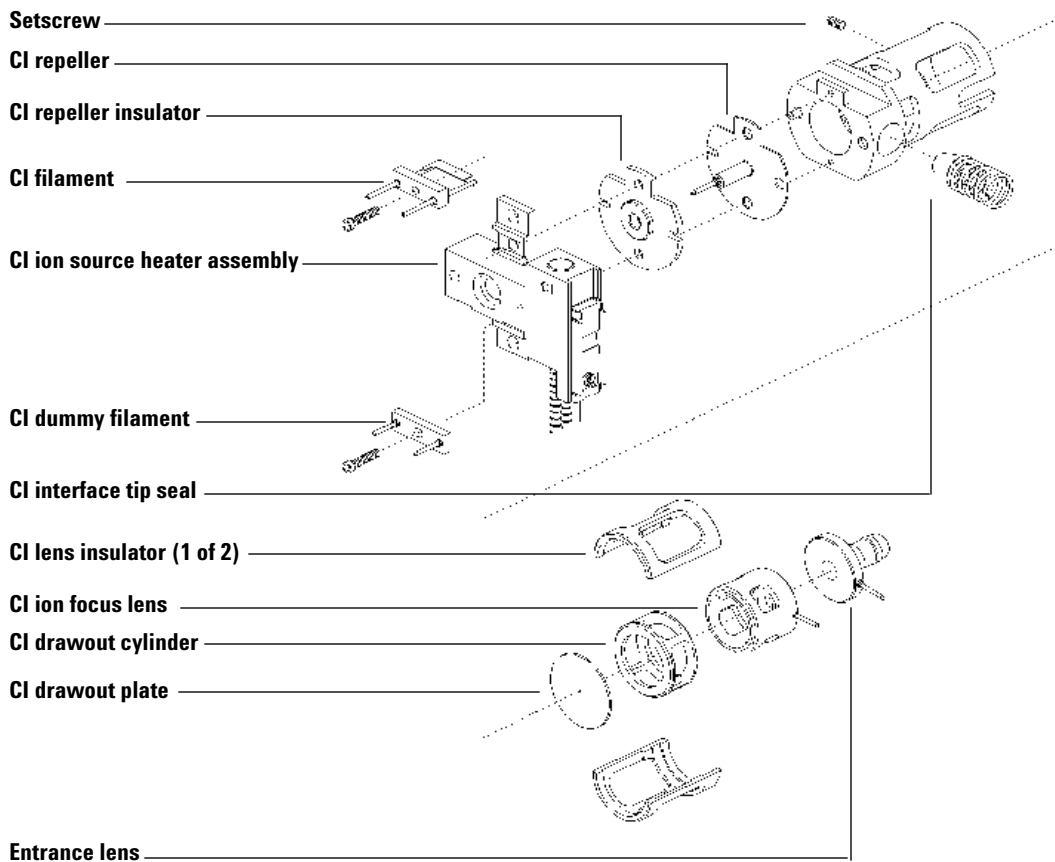

Figure 46 CI ion source exploded view

Filaments

Two filaments (Figure 46) are located on opposite sides of the outside of the EI ion source. The **active** filament carries an adjustable AC emission current. The emission current heats the filament causing it to emit electrons which ionize the sample molecules. In addition, **both** filaments have an adjustable DC bias voltage. The bias voltage determines the energy on the electrons, usually -70 eV.

The CI ion source has only one filament of a different design from the EI filaments. A “dummy” filament provides connections for the Filament 2 wires.

The filament is shut off automatically if there is a general instrument shutdown. Three parameters affect the filaments: filament selection (Filament), filament emission (Emission) current, and electron energy (EIEnrgy).

Filament selection

The filament selection parameter (Filament) selects which filament in the ion source is active. In the CI source, it is always Filament 1.

Sometimes, one EI filament will give better performance than the other. To select the better of the two filaments, run two autotunes, one with each filament. Use the filament that gives the best results.

Emission current

The filament emission current (Emission) is variable between 0 and -315 μA , but should be set to the software default for normal operation.

Electron energy

The electron energy (EIEnrgy) is the amount of energy on the ionizing electrons. It is determined by the bias voltage; -70 VDC bias on the filament causes emitted electrons to possess -70 eV (electron volts). This value is adjustable from -5 to -241 VDC, but for normal operation, set this parameter to 70.

Filament care

Like the filaments in incandescent light bulbs, the ion source filaments will eventually burn out. Certain practices will reduce the chance of early failure:

- If you have an optional G3397A Micro-Ion vacuum gauge, use it to verify that the system has an adequate vacuum before turning on the analyzer, especially after any maintenance was performed.
- If you are controlling your MSD from the Edit Parameters screen, always select MSOff before changing any of the filament parameters.
- When setting up data acquisition parameters, set the solvent delay so that the analyzer will **not** turn on while the solvent peak is eluting.
- When the software prompts Override solvent delay? at the beginning of a run, **always** select NO.
- Higher emission current will reduce filament life.
- Higher electron energy will reduce filament life.
- Leaving the filament on for short times (≤ 1 minute) during data acquisition will reduce filament life.

Other Source Elements

Magnet

The field created by the magnet directs the electrons emitted by the filament into and across the ionization chamber. The magnet assembly is a permanent magnet with a charge of 350 gauss in the center of the field.

Repeller

The repeller (Figure 46) forms one wall of the ionization chamber. A positive charge on the repeller pushes positively-charged ions out of the source through a series of lenses. The repeller voltage is also known as the ion energy, although the ions only receive about 20% of the repeller energy. The repeller voltage can be varied from 0 to +42.8 VDC. Some tune programs use a fixed repeller voltage. Others ramp the repeller voltage to find the optimum setting.

- Setting repeller voltage too low results in poor sensitivity and poor high mass response.
- Setting repeller voltage too high results in precursors (poor mass filtering) and poor low mass resolution.

Drawout plate and cylinder

The drawout plate (Figure 46) forms another wall of the ionization chamber. The ion beam passes through the hole in the drawout plate and into the drawout cylinder. The drawout cylinder is slotted. The slots correspond to slots in the source body. These slots allow carrier gas and un-ionized sample molecules or fragments to be pulled away by the vacuum system. The drawout plate and drawout cylinder are both at ground potential.

Ion focus

The voltage on the ion focus lens (Figure 46) can be varied from 0 to -127 VDC. A typical voltage is between -70 and -90 VDC. In general:

- Increasing the ion focus voltage improves sensitivity at lower masses.
- Decreasing the ion focus voltage improves sensitivity at higher masses.
- Incorrect ion focus adjustment results in poor high mass response.

Entrance lens

The entrance lens (Figure 46) is at the entrance to the quadrupole mass filter. This lens minimizes the fringing fields of the quadrupole which discriminate against high-mass ions. There is a permanent +4.4 volt voltage added to the entrance lens. The total voltage applied to the entrance lens is the sum of the entrance lens offset and entrance lens gain and the +4.4 volt permanent offset.

Entrance lens voltage = +4.4 VDC + offset + (gain × mass)

Entrance lens offset

The entrance lens offset (EntOff) controls the fixed voltage applied to the entrance lens. It can be varied from 0 to -64 VDC (-20 V is typical). Increasing the entrance lens offset generally increases the abundance of ions at low masses without substantially decreasing the abundance of high mass ions.

Entrance lens gain

Entrance lens gain (EntLens) controls the variable voltage applied to the entrance lens. It determines how many volts are applied for each m/z . It can be varied from 0 to -128 mV/(m/z). A typical range is 0 to -40 mV/amu.

Quadrupole Mass Filter

The mass filter separates ions according to their mass-to-charge ratio (m/z). At a given time, only ions of a selected mass-to-charge ratio can pass through the filter to the detector. The mass filter in the MSD is a quadrupole (Figure 47).

The quadrupole is a fused-silica (quartz) tube coated with a thin layer of gold. The four hyperbolic surfaces create the complex electric fields necessary for mass selection. Opposing segments are connected; adjacent segments are electrically isolated. One pair has positive voltages applied, the other negative.

A combined direct current (DC) and radio frequency (RF) signal is applied to the two pairs of segments. The magnitude of the RF voltage determines the mass-to-charge ratio of the ions that pass through the mass filter and reach the detector. The ratio of DC-to-RF determines the resolution (widths of the mass peaks). There are several parameters that control the DC and RF voltages. All these parameters are set by Autotune, but also can be manually adjusted in the Edit Parameters window:

- AMU gain (AmuGain)
- AMU offset (AmuOffs)
- 219 width (Wid219)
- DC polarity (DC Pol)
- Mass (axis) gain (MassGain)
- Mass (axis) offset (MassOffs)

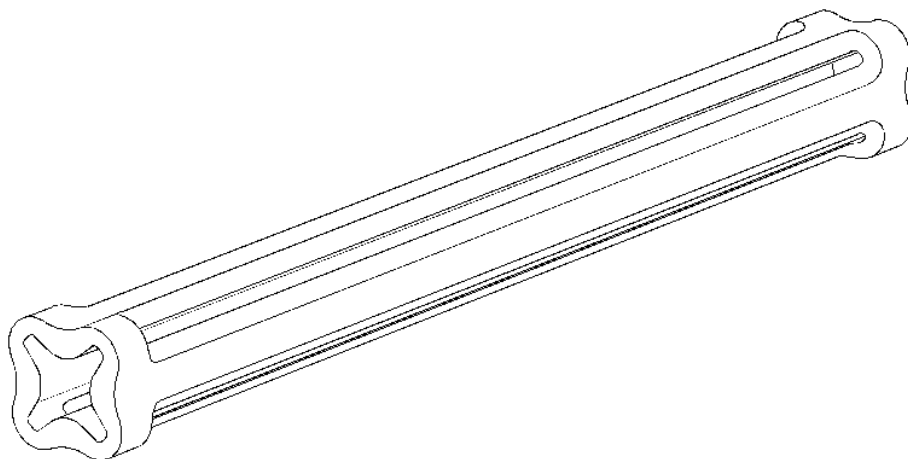

Figure 47 Quadrupole mass filter

AMU gain

AMU gain (AmuGain) affects the ratio of DC voltage to RF frequency on the mass filter. This controls the widths of the mass peaks.

- Higher gain yields narrower peaks.
- AMU gain affects peaks at high masses more than peaks at low masses.

AMU offset

AMU offset (AmuOffs) also affects the ratio of DC voltage to RF frequency on the mass filter.

- Higher offset yields narrower peaks.
- AMU offset generally affects peak widths equally at all masses.

219 width

m/z 219 is a prominent ion near the middle of the mass range of PFTBA. The width parameter (Wid219) makes small corrections to the m/z 219 peak width. Amu gain and amu offset must be readjusted after the 219 width is changed. If you are tuning with a compound other than PFTBA, there may not be an ion at m/z 219. In that case, set the 219 width to the last value found for it by Autotune or set it to 0.

DC polarity

The DC polarity (DC Pol) parameter selects the orientation of the direct current applied to the quadrupole mass filter. The DC polarity that works best for your MSD is determined at the factory. It is listed on the final test sheet accompanying your MSD. It is also listed on a label on the cover over the RF coils. This cover can be viewed by removing the upper MSD cover.

CAUTION

Using the nonpreferred DC polarity may result in very poor performance. Always use the factory-specified polarity.

Mass (axis) gain

Mass gain (MassGain) controls the mass assignment, that is, assignment of a particular peak to the correct m/z value.

- A higher gain yields higher mass assignment.
- Mass gain affects peaks at high masses more than peaks at low masses.

Mass (axis) offset

Mass offset (MassOffs) also controls the mass assignment.

- A higher offset yields higher mass assignment.
- Mass offset generally affects peaks equally at all masses.

Quadrupole maintenance

The mass filter requires no periodic maintenance. It should not be removed from the radiator. If **absolutely** necessary (that is, if the only alternative is replacement), the quadrupole can be cleaned. Cleaning *must* be performed by Agilent Technologies service personnel.

CAUTION

Never put the quadrupole in an ultrasonic cleaner.

Never change the physical orientation of the quadrupole mass filter.

The fused-quartz quadrupole is fragile and will break if dropped or handled roughly.

The material in the cusps of the quadrupole is very hygroscopic. If exposed to water, the quadrupole must be dried very slowly to prevent damage.

Detector

The detector (Figure 48) in the MSD analyzer is a high energy conversion dynode (HED) coupled to an electron multiplier (EM). The detector is located at the exit end of the quadrupole mass filter. It receives the ions that have passed through the mass filter. The detector generates an electronic signal proportional to the number of ions striking it. The detector has three main components: the detector ion focus, the HED and the EM horn.

Detector ion focus

The detector ion focus directs the ion beam into the HED, which is located off axis. The voltage on the detector focus lens is fixed at -600 V.

High energy dynode

The HED operates at $-10,000$ volts for EI and PCI, and $+10,000$ volts for NCI. It is located off-axis from the center of the quadrupole mass filter to minimize signals due to photons, hot neutrals, and electrons coming from the ion source. When the ion beam hits the HED, electrons are emitted. These electrons are attracted to the more positive EM horn. Do not touch the insulator.

EM horn

The EM horn carries a voltage of up to -3000 volts at its opening and 0 volts at the other end. The electrons emitted by the HED strike the EM horn and cascade through the horn, liberating more electrons as they go. At the far end of the horn, the current generated by the electrons is carried through a shielded cable outside the analyzer to the signal amplifier board.

The voltage applied to the EM horn determines the gain. The voltage is adjustable from 0 to -3000 VDC. Use the EM voltage found in autotune as a baseline for the EM voltage setting.

- To increase signal gain, increase the EM voltage.
- For concentrated samples where less signal gain is needed, decrease the EM voltage.

As the EM horn ages, the voltage (EMVolts) required increases over time. If the EM voltage must always be set at or near -3000 VDC to complete Autotune, with no other probable cause, it may need to be replaced. Check your tune charts for gradual degradation, which indicates wearing out. Select View Tunes from the Checkout menu in the Instrument Control view to see the tune charts. Sudden changes usually indicate a different type of problem.

See Also

- *Troubleshooting in the online help for more information about symptoms that may indicate EM problems.*

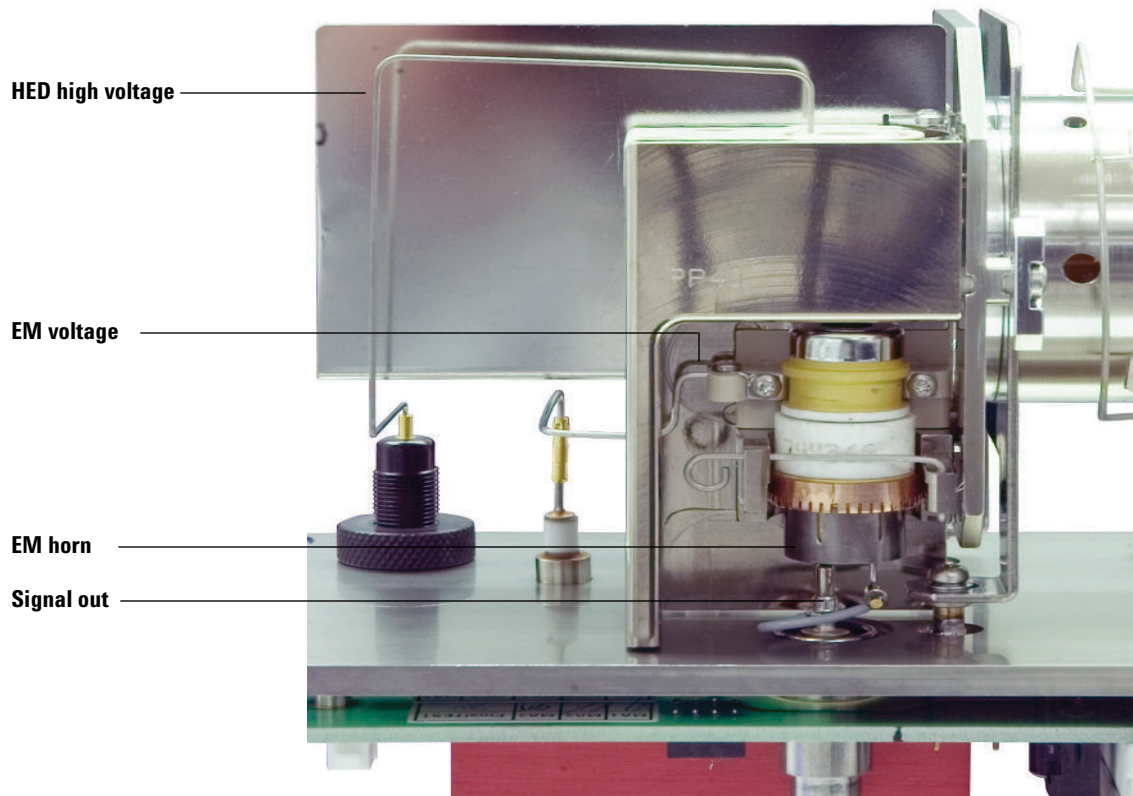

Figure 48 The detector

Analyzer Heaters and Radiators

The ion source and mass filter are housed in cylindrical aluminum tubes called radiators (Figure 49). The radiators control the distribution of heat in the analyzer. They also provide electrical shielding for analyzer components. The source heater and temperature sensor are mounted in the source heater block. The mass filter (quad) heater and temperature sensor are mounted on the mass filter radiator. Analyzer temperatures can be set and monitored from the MSD ChemStation.

In selecting the temperatures to use, consider the following:

- Higher temperatures help keep the analyzer clean longer.
- Higher ion source temperatures result in more fragmentation and therefore lower high-mass sensitivity.

After pumpdown, it takes at least 2 hours for the analyzer to reach thermal equilibrium. Data acquired sooner may not be reproducible.

Recommended settings (for EI operation):

- Ion source 230 °C
- Quadrupole 150 °C

CAUTION

Do not exceed 200 °C on the quadrupole or 350 °C on the ion source.

The GC/MSD interface, ion source, and mass filter (quad) heated zones interact. The analyzer heaters may not be able to accurately control temperatures if the setpoint for one zone is much lower than that of an adjacent zone.

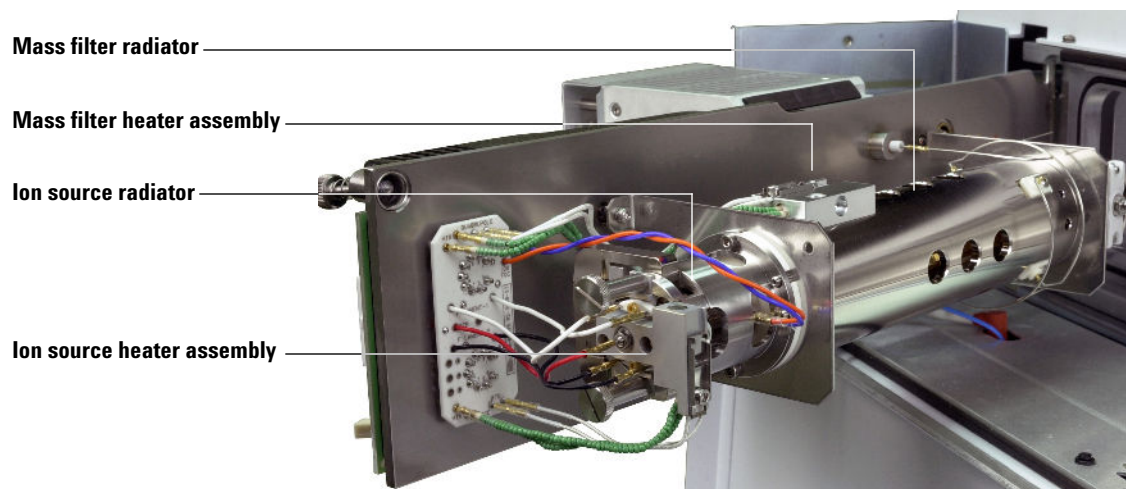

Figure 49 Heaters and radiators



8 Electronics

Local Control Panel and Power Switch	217
Side Board	218
Electronics Module	219
LAN/MS Control Card	223
Power Supplies	224
Back Panel and Connectors	225
Interfacing to External Devices	228

Except for the *Back panel and connectors*, *Status display and power switch*, and *Interfacing to other devices* sections, most of this material is not essential for day-to-day operation of the MSD. It may be of interest to persons responsible for servicing the MSD ([Figure 50](#)).

WARNING

Dangerous voltages are present under the safety covers. Do not remove safety covers. Refer servicing to your Agilent Technologies service representative.



8 Electronics

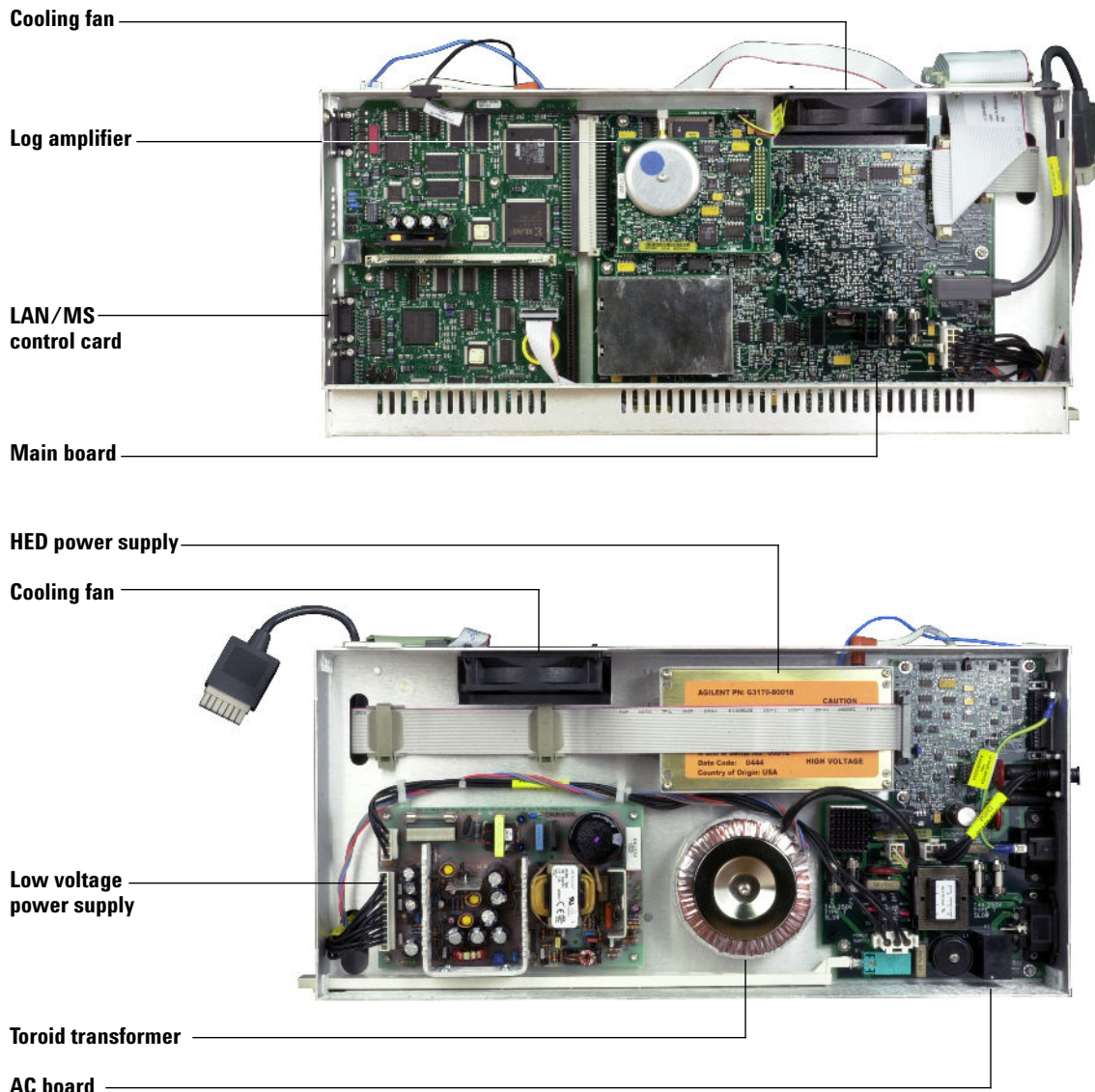

Figure 50 The electronics module

Local Control Panel and Power Switch

Local Control Panel (LCP)

You can view MSD system status and perform some control functions from the local control panel on the front of the instrument.

Functions available through the local control panel include:

- Prepare to vent (cool analyzer and turn off high vacuum pump)
- Monitor MSD status
- Run autotune
- Run method
- Run sequence
- View and set analyzer temperatures

See also

The G1701EA *GC/MSD ChemStation Getting Started* manual.

Power switch

The power switch is part of the electronics module and is located on the lower left of the front of the MSD. It is used to turn the MSD and foreline pump on and off.

CAUTION

Do not switch the MSD off unless it has completed the vent program. Incorrect shutdown can seriously damage the MSD.

Side Board

The side board is mounted on the side plate. It performs these functions:

- Provides the 1 MHz reference clock for the RF amplifier.
- Generates the RF component of the voltage applied to the quadrupole mass filter according to a signal from the main board. The amplitude of this voltage is proportional to the mass selected.
- Generates the DC component of the voltage applied to the quadrupole mass filter. The magnitude of this voltage is proportional to the RF voltage.
- Passes voltages generated on the main board and the detector focus voltage from the HED power supply to elements in the ion source and the detector.
- Generates and adjusts filament emission current and electron energy as controlled by the main board.
- Switches the filament power from one filament to the other.
- Monitors for RF faults and shuts down the analyzer if one is detected.

Electronics Module

Most of the electronics in the MSD are contained in the electronics module. The whole electronics module can be replaced, if necessary, by your Agilent Technologies service representative.

The electronics module contains:

- Main board
- Signal amplifier board
- LAN/MS control card
- AC board (power distribution / vacuum control board)
- Low voltage (AC-DC) power supply
- High voltage (HED) power supply
- Toroid transformer assembly

Main board

The main board is mounted on the outer side of the electronics module. The main board performs these functions:

- Receives and decodes digital instructions from the LAN/MS control card.
- Sends digital information to the LAN/MS control card.
- Generates voltages for the ion source lenses.
- Generates control signals for filament selection, filament emission current, and electron energy. Generates control signals for quadrupole RF drive, quad frequency adjustment, DC polarity selection, and all detector voltages.
- Performs analog-to-digital conversion for the Direct signal, ion source and mass filter temperature signals, and foreline pressure or turbo pump speed signal.
- Monitors the signals from the vacuum system and fans and the filament status, HV fault and RF fault signals from the side board. Activates the shutdown line when the analyzer electronics must be disabled.
- Generates the control signals (on and off) used by the AC board for the high vacuum pump and calibration valve.
- Generates ± 280 VDC (nominal) power for main board lens amplifiers and side board DC amplifiers.

- Supplies and controls the power for the ion source and quadrupole (mass filter) heaters.
- Provides 24 VDC power for the cooling fans.

Signal amplifier board

The signal amplifier board amplifies the output of the detector. It produces an output voltage of 0 to 10 volts DC, proportional to the logarithm of the input current of 3 picoamps to 50 microamps.

An analog-to-digital converter converts the amplifier output voltage to digital information. The LAN/MSD control card converts the data into abundance counts proportional to the detector signal current.

AC board

The AC board is mounted on the opposite side of the electronics panel from the LAN/MSD control card. The AC board is also sometimes called the power distribution/vacuum control board. It performs these functions:

- Provides input voltage transparency for the MSD.
- Distributes AC line power to the AC/DC power supply, the foreline pump, and the turbo pump controller.
- Turns the calibration valve on or off as directed by the main board.
- Provides the voltage for the calibration valve.
- Provides a logic interface to turbo controller.
- Controls the diffusion pump:
 - Controls the foreline gauge.
 - Turns on the diffusion pump once the foreline pressure is low enough, as directed by the main board.
 - Regulates the AC power to the diffusion pump heater.
 - Turns off the diffusion pump if the foreline pressure is too high or if the diffusion pump is too hot.
- Passes the foreline pressure signal from the foreline gauge or turbo pump speed and other vacuum status information to the main board.
- Turns off the foreline pump in case of a problem with pumpdown.

Diffusion pump control

The power regulator ensures that the diffusion pump heater receives constant power, even if there are fluctuations in the AC line voltage. It measures the voltage across the heater and the current through it, multiplies them together, and compares the result with a standard value. Any discrepancy is applied as an error signal to adjust the power.

If the power distribution board senses a malfunction in the diffusion pump power regulator, it shuts off power to the diffusion pump. See [Figure 51](#).

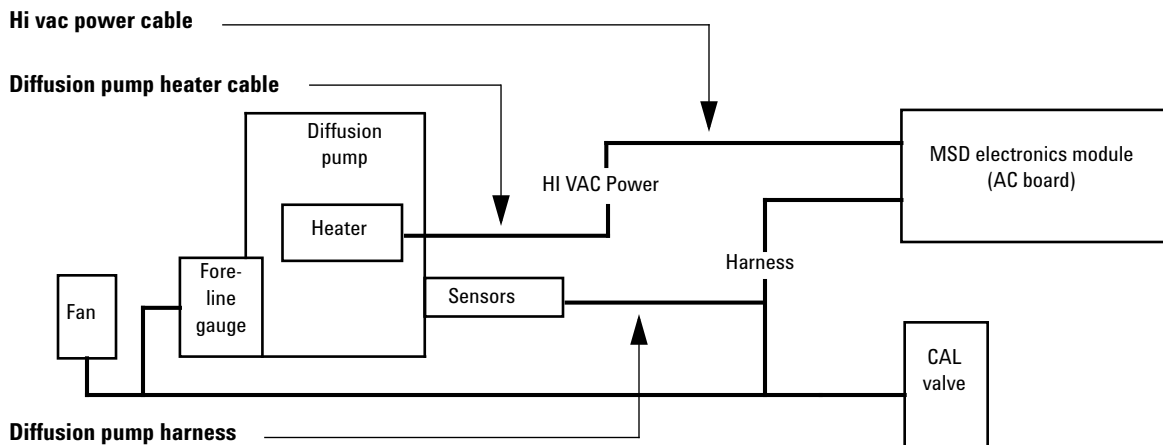

Figure 51 Diffusion pump control

Turbo pump control

Your MSD is equipped with a turbo pump with an integrated controller.

The AC board sends control signals to, and receives turbo pump status information from, the turbo pump controller. The turbo pump controller provides power to the turbo pump and regulates pump speed. If the pump fails to reach 80% speed within 7 minutes after beginning pumpdown or if the speed drops below 50% during operation, the controller shuts off the turbo pump and the AC board shuts off the foreline pump.

Pumpdown failure shutdown

The AC board will shut down both the high vacuum and the foreline pump if the system fails to pump down correctly. One condition that triggers shutdown is turbo pump speed below 80% after 7 minutes, or if the foreline pressure is above 300 mTorr after 7 minutes.

This is usually because of a *large* air leak: either the sideplate has not sealed correctly or the vent valve is still open. This feature helps prevent the foreline pump from sucking air through the system, which can damage the analyzer and pump.

To correct the problem, power cycle the MSD and troubleshoot. You have 7 minutes to find and correct the air leak before the system shuts down again. Be sure to press on the side plate when turning on the MSD power to ensure a good seal.

LAN/MS Control Card

The LAN/MS control card is located to the left of the main board on the electronics panel. The LAN/MS control card has two main functions:

- Providing a communication interface between the MSD and the data system.
- Providing real-time control of the MSD, freeing the data system for other tasks.

Functional areas of the LAN/MS control card include:

- Instrument controller
- Data processor
- Main processor
- Serial communication processor
- Network communication controller
- Remote start processor
- Random access memory (RAM)
- Status LEDs
- Local Control panel firmware

LEDs on the LAN/MS control card are visible on the rear panel. The upper two LEDs indicate network communication.

The two bottom LEDs are the power (On, digital 5V) and the “heartbeat” indicator. The flashing heartbeat LED indicates that the operating system of the MSD is functioning. In case of catastrophic loss of flash memory, the heartbeat flashes in an SOS (•••- - - •••) pattern.

Power Supplies

Low voltage (AC-DC) power supply

The low voltage power supply is mounted next to the toroid transformer in the electronics module. A universal input power supply, it converts AC line voltage into the DC voltages used by the rest of the electronics. The power supply generates the following DC voltages:

- +24 V (nominal)
- +15 V (nominal)
- -15 V (nominal)
- +5 V (nominal)

High voltage (HED) power supply

The high voltage power supply provides the -10,000 volts DC for the high energy dynode (HED) in the detector for the EI MSD. The EI/PCI/NCI MSD (G3174A) requires a bipolar power supply that can also provide +10,000 volts for NCI operation. The HED power supply also provides 600 VDC for the detector focus lens. Due to the high impedance of this circuit, measuring the detector focus voltage with a handheld voltmeter will give a typical reading of 90 to 100 volts where the polarity matches that of the HED voltage.

Toroid transformer

The toroid transformer is mounted next to the AC board. It provides 24 VAC for the mass filter and source heater circuits. The input wires take 120 VAC or 200 to 260 VAC from the AC board. The AC board samples the line voltage and uses a relay to appropriately strap the toroid primary. The output wires connect to the main board.

Back Panel and Connectors

The back panel ([Figure 52](#)) contains several connectors, the primary fuses, and several status LEDs. Most of these components are part of the AC board or the LAN/MS control card and extend through the back panel.

High vacuum control (HIVAC SIGNAL) connector

The high vacuum signal connector is on the AC board. See “[Turbo pump control](#)” on page 221 and “[Diffusion pump control](#)” on page 221.

High vacuum power (HIVAC POWER) connector

The high vacuum power connector carries power for the diffusion pump heater or the turbo controller from the AC board.

Primary fuses

The primary fuses limit current into the MSD in case of a short circuit in the foreline pump. The primary fuses are on the AC board.

Power cord receptacle

The AC power cord brings in all electrical power for the MSD. The power cord can be detached from the MSD.

Foreline pump power cord receptacle

The foreline pump power cord receptacle provides AC power for the foreline pump. If the power switch is off, no power is supplied to the foreline pump.

Remote start connector

The remote start connector is the external connector for the remote start circuitry on the LAN/MS control card. It receives remote start signals from the GC.

RS-232 Serial A connector

Not currently used.

RS-232 Serial B connector

The RS-232 Serial B connector goes to the CI flow module or to the Micro-Ion vacuum gauge, depending on the accessories installed on the MSD. It handles data communication between the GC and the MSD.

LAN (I/O) connector

The LAN cable from the data system is connected to the I/O LAN connector. This cable carries all data communication between the PC and the MSD.

LAN/MSD control card LEDs

The upper two LEDs indicate network communication. The two bottom LEDs are the power and the “heartbeat” indicator.

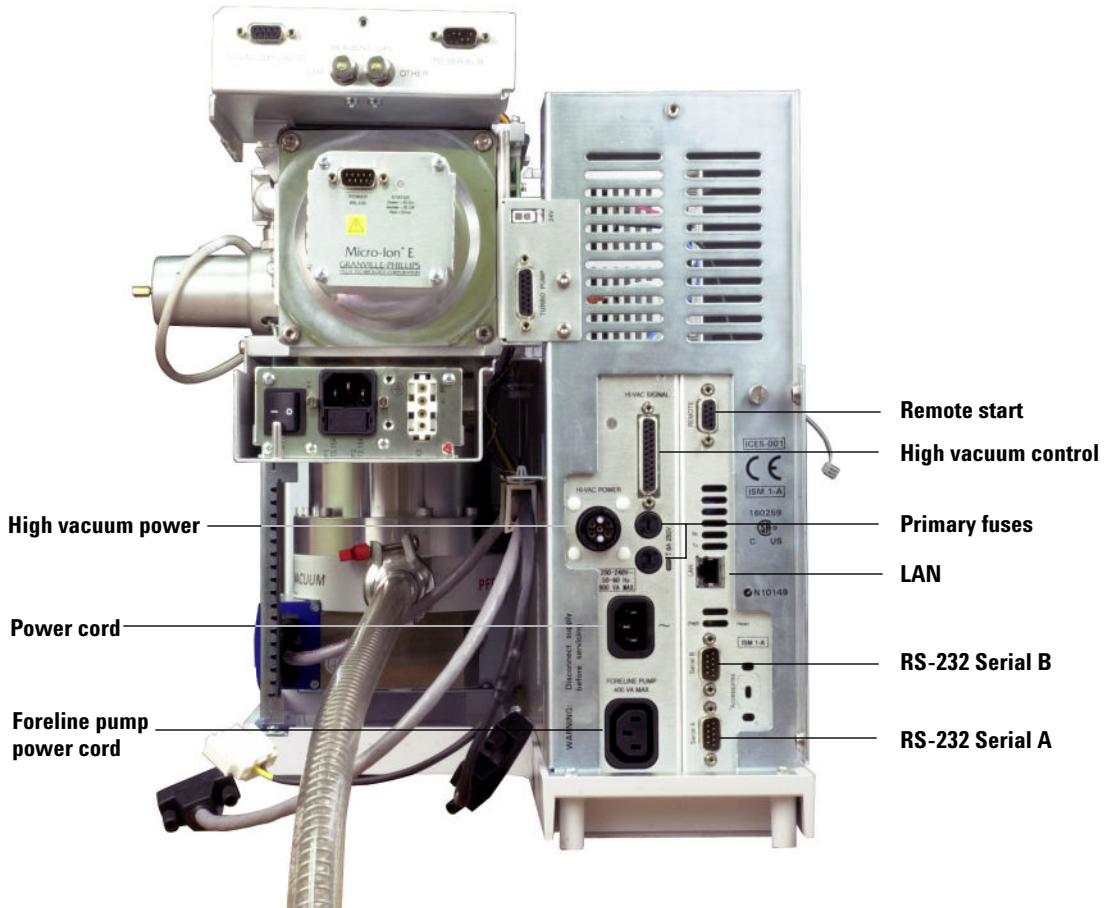

Figure 52 Back panel connections

Interfacing to External Devices

Remote control processor

The remote control processor on the LAN/MS control card synchronizes start-run signals with GCs and other devices. The functions of the remote control processor are extended to the remote start (Remote) connector (Figure 53) on the back panel of the MSD. The remote start cable connects the GC and the MSD.

Remote start signals

It is often necessary to communicate with external devices (for example, a purge-and-trap) during a run. Typically, these communications are requests to send a system-ready signal. They also include:

- Receive a start run signal from an external device
- Program the timing of events during a run

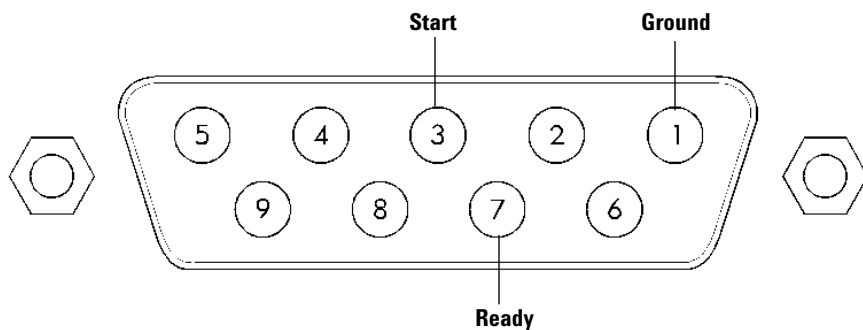

Figure 53 Remote start connector

System ready

When interfacing to an external device, it is often desirable to send a system-ready signal to the device. In the case of a multisample Tekmar purge-and-trap, each sample is purged onto a trap where it waits for a ready

signal. On receipt of the ready signal, the desorbition cycle begins. When a specific temperature is reached, the purge-and-trap closes a contact to indicate the run has started.

The ready pin on the remote start connector on the GC is held low at all times except when the GC, MSD, and data system are all ready. On system ready, a logic high of 5 VDC is present between that pin and any ground. This same high can be detected between the ready and ground pins on the remote start connector on the MSD.

Start run input

The best way to generate a start run signal is to use the remote start connector on the GC. Since remote start cables are made for most common devices, this is often the simplest way. A general-purpose remote start cable (05890-61080), is also available which terminates in spade lugs. Care must be taken to ensure that the system is actually ready before the start run signal is sent.

If necessary, the remote start connector on the back of the MSD can be used to send the start run signal. A contact closure between the start and ground pins will start the run if the system is ready.

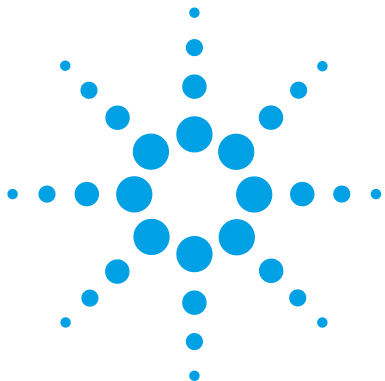

9 Parts

To Order Parts	232
Electronics	233
Cables	233
Printed circuit boards	235
Fuses and power switch	237
Local Control Panel	238
Vacuum System	240
O-rings and seals	240
Standard foreline pump and related parts	241
Diffusion pump and related parts	245
Turbo pump and related parts	247
Analyzer	250
EI source	255
Repeller assembly	257
Heater sensor assembly	257
EI GC/MSD Interface	259
Consumables and Maintenance Supplies	260
CI Parts	265

This chapter lists parts that can be ordered for use in maintaining your 5975 Series MSD. It includes most of the parts or assemblies in the MSDs. This chapter is organized so that related parts are grouped together.

Some of the parts listed are not user-replaceable. They are listed here for use by Agilent Technologies service representatives.



To Order Parts

To order parts for your MSD, address the order or inquiry to your local Agilent Technologies office. Supply them with the following information:

Model and serial number of your MSD, located on a label on the lower left side near the front of the instrument.

- Part number(s) of the part(s) needed
- Quantity of each part needed

Some parts are available as rebuilt assemblies

Rebuilt assemblies pass all the same tests and meet all the same specifications as new parts. Rebuilt assemblies can be identified by their part numbers. The first two digits of the second part of the part number are 69 or 89 (such as xxxxx-69xxx or xxxxx-89xxx). Rebuilt assemblies are available on an exchange-only basis. When you return the original part to Agilent Technologies (after you receive the rebuilt assembly) you will receive a credit.

If you cannot find a part you need

If you need a part that is not listed in this chapter, check the Agilent Technologies Analytical Supplies Catalog or the on-line catalogue on the worldwide web at <http://www.agilent.com/chem>. If you still cannot find it, contact your Agilent Technologies service representative or your Agilent Technologies office.

Electronics

The printed circuit boards in the MSD are available only as complete assemblies. Individual electronic components are not available. This section contains the following parts: cables (Tables 11 and 12), printed circuit boards (Table 13 and Figure 54), and fuses and switches (Table 14).

Cables

Table 11 External cables

Description	Part number
Remote Start-Stop cable*	G1530-60930
Y-Remote Start-Stop Cable*	G1530-61200
H-Remote Start-Stop Cable*	35900-60800
LAN Cable (shielded)	8121-0008
Power cord, Australia, New Zealand	8120-1369
Power cord, Chile	8120-6978
Power cord, China	8121-0723
Power cord, Denmark	8120-2956
Power cord, Europe	8120-1689
Power cord, DK/Greenland	8120-3997
Power cord, India/South Africa	8120-4211
Power cord, Israel	8120-5182
Power cord, Korea	8121-1226
Power cord, Argentina	8120-6869
Power cord, Japan 200V	G2025-60189
Power cord, Switzerland	8120-2104
Power cord, UK, Hong Kong, Singapore, Malaysia	8120-8705
Power cord, US	8120-6825

* Only one cable can be used at a time

Table 12 Internal cables

Description	Part number
AC board control cable (AC board to main board)	G1099-60422
Chassis ground wire	G1099-60433
Local control panel ribbon cable	G3170-60830
Electronics module fan cable	G1099-60560
Diffusion pump control cable	G3170-60437
Fan (high vacuum) cable	G1099-60561
Feedthrough board	G1099-60425
HED control cable	G1099-60430
HED power cable	G1099-60431
High Vacuum power extender cable (AC to back panel)	G1099-60436
Low voltage power supply input cable (AC to LVPS)	G1099-60426
Low voltage power supply output cable (LVPS to main board)	G1099-60427
Mass filter contact cable kit	G3170-60130
Side board control (ribbon) cable (main board to side board)	G1099-60410
Signal cable (signal feedthrough on side plate to signal amp board)	G1099-60416
Source power cable (main board to side board)	G1099-60428
Turbo pump wiring harness cable (panel-turbo controller and ps)	G3170-60835
Turbo pump controller to TMH Card	G3170-60818
Turbo pump power cable	G3170-60833
CI RS232s to CI Control Board	G3170-60807
CI Flow Module cable – SmartCard to CI Flow *	G3170-60808
Micro-Ion Vacuum Gauge cable – SmartCard to Gauge	G3170-60808
Micro-Ion Vacuum Gauge cable – CI Flow to Gauge	G3170-60805

* No CI on instrument then cable will go directly to the Micro-Ion Vacuum Gauge from the Smart-Card

Printed circuit boards

Table 13 Printed circuit boards (Figure 54)

Description	Part number
AC board	G3170-65006
Fan for electronics module	3160-1038
Snap-on rivets (4) may be required if old ones are broken by the removal process	0361-1341
HED power supply	G3170-80017
Bipolar HED power supply	G3170-80018
LAN/MS Control Card – SC3+	05990-65430
Low voltage (AC-DC) power supply	0950-3067
Main board	G3170-65010
LogAmp Fast Electronics	G3170-65001
Toroid transformer	G1099-60229
Local control panel assembly (LCP) - Generic	G3170-60195
Side board, new	G3170-65015
Side board, rebuilt	G3170-69015

9 Parts

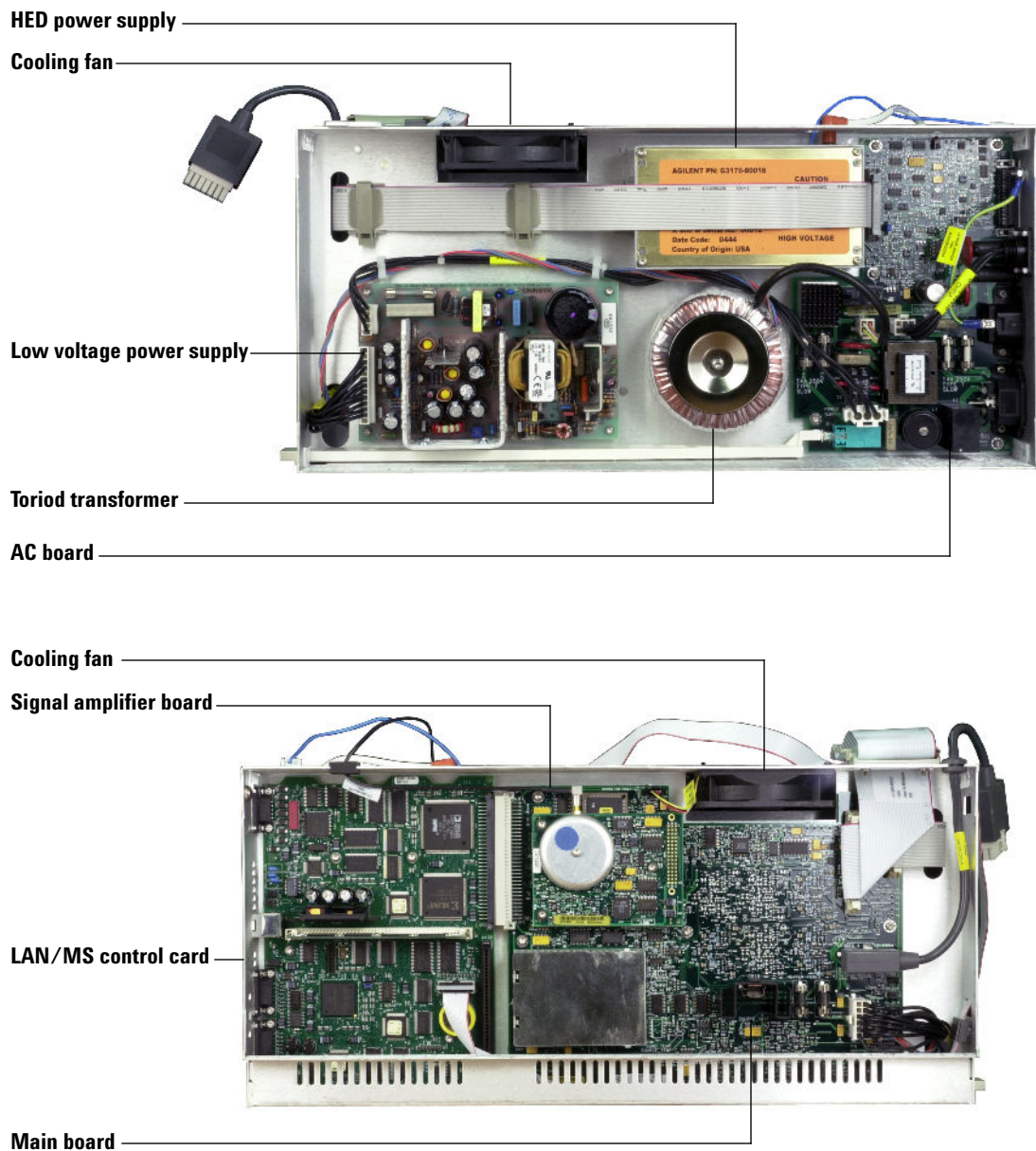

Figure 54 Electronics module

Fuses and power switch

Table 14 Fuses and power switches

Description	Part number
Fuse 8A, 250V	2110-0969
Power button	5041-1203
Power switch extender rod	G3170-40050

Local Control Panel

This section lists replaceable parts for the LCP and related covers. See [Table 15](#).

Table 15 LCP and related parts ([Figure 55](#))

Item	Description	Part number
1	LCP fascia	
	• for 5975C VL MSD	G3170-60081
	• for 5975C inert MSD	G3170-60082
	• for 5975C inert XL MSD	G3170-60083
	• for 5975C inert XL EI/CI MSD	G3170-60084
	• for 5975 series MSD (clear)	G3120-60038
	• for 7820A MSD (black)	G3170-60018
2	LCP fascia with LCP board	
	• for 5975C VL MSD	G3170-60181
	• for 5975C inert MSD	G3170-60182
	• for 5975C inert XL MSD	G3170-60183
	• for 5975C inert XL EI/CI MSD	G3170-60184
	• for 5975 series MSD (clear)	G3170-60195
	• for 7820A MSD (black)	G3170-60196

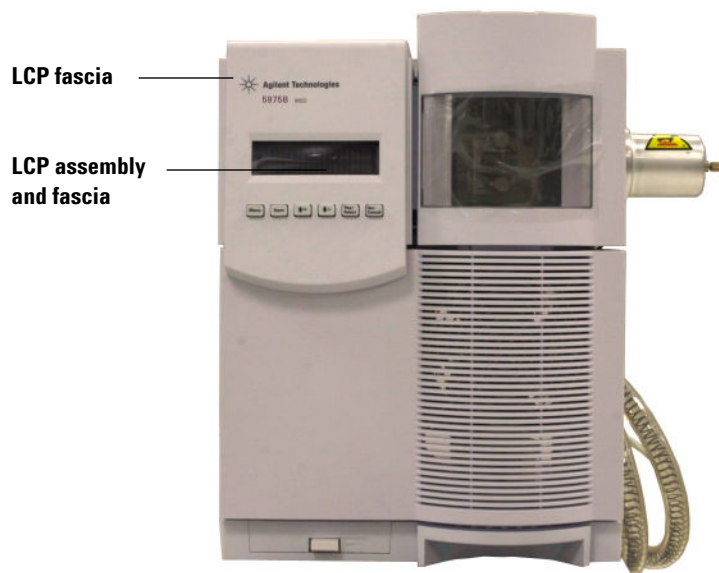

Figure 55 LCP replacement parts

Vacuum System

This section lists replacement parts available for the vacuum system. It includes clamps, O-rings and seals (Table 16), standard foreline pump and related components (Table 17 and Figure 56), dry foreline pump and related components (Table 18 and Figure 57), diffusion pump and related components (Table 19 and Figure 58), and turbo pump vacuum system components (Table 20 and Figure 59).

O-rings and seals

Table 16 O-rings and seals

Description	Part number
Calibration valve O-ring (1/4-inch)	5180-4182
End plate O-ring (for front and rear end plates)	0905-1441
GC/MSD interface O-ring	0905-1405
HED feedthrough	G1099-80012
HED feedthrough O-ring	0905-0490
KF10/16 seal (foreline pump inlet and diffusion pump outlet), Micro-Ion vacuum gauge	0905-1463
KF50 seal (diffusion pump inlet)	0100-1884
KF25 O-ring assembly (turbo pump outlet)	0100-1551
KF elbow adapter for standard turbo pump outlet	G2589-20041
O-ring for standard turbo pump inlet or diffusion pump baffle adapter	0905-1443
Seal, performance turbo pump inlet	0100-1879
Side plate O-ring	0905-1442
Vent valve O-ring (1/4-inch)	5180-4182

Standard foreline pump and related parts

Table 17 Standard foreline pump and related parts (Figure 56)

Item	Description	Part number
	Foreline hose assembly (hose and internal spring)	05971-60119
	• Hose Clamp* used with 05971-60119	1400-3241
1	Standard foreline pump – 120V – Pfeiffer Duo 2.5	G3170-89025
1	Standard foreline pump – 220V – Pfeiffer Duo 2.5	G3170-89026
1	Standard foreline pump – 200V – Pfeiffer Japanese Version	G3170-89024
	Foreline pump inlet seal (KF10/16)	0905-1463
	KF10/16 Clamp (foreline inlet), Micro-Ion vacuum gauge	0100-1397
	Foreline Hose packaging cap – flange	G3170-40132
	KF16 Hose adapter	G1099-20531
	KF25 Clamp (tp end of hose – not shown)	0100-0549
	KF25 Hose adapter (tp end of hose – not shown)	G1099-20532
	Oil drip tray	G1099-00015
	Drain plug for foreline pump	0100-2452
	O-ring for foreline pump drain plug	0905-1619
	Fill plug	0100-2451
	O-ring for foreline fill plug	0905-1620
	Oil mist filter	G1099-80039
	Hose barb adapter (exhaust fitting)	G3170-80006
	O-ring for oil mist filter and hose barb adapter	0905-1193
	Foreline pump oil	6040-0621
	Safety Cage kit, Foreline pump	G3170-60028
	Safety Cage, Foreline pump Qty. 1	
2	Sheetmetal	
3	Warning sticker	
4	Rubber grommet	
5	Standoff, Pump Cage Qty. 2	G3170-20035

Table 17 Standard foreline pump and related parts (Figure 56)

Item	Description	Part number
6	M6 Acorn Cap Hex nut Qty. 2	0535-0041
7	M4 Internal Star washer Qty. 2	2190-0009

* Hose clamps are interchangeable, but give an optimum fit if they are matched

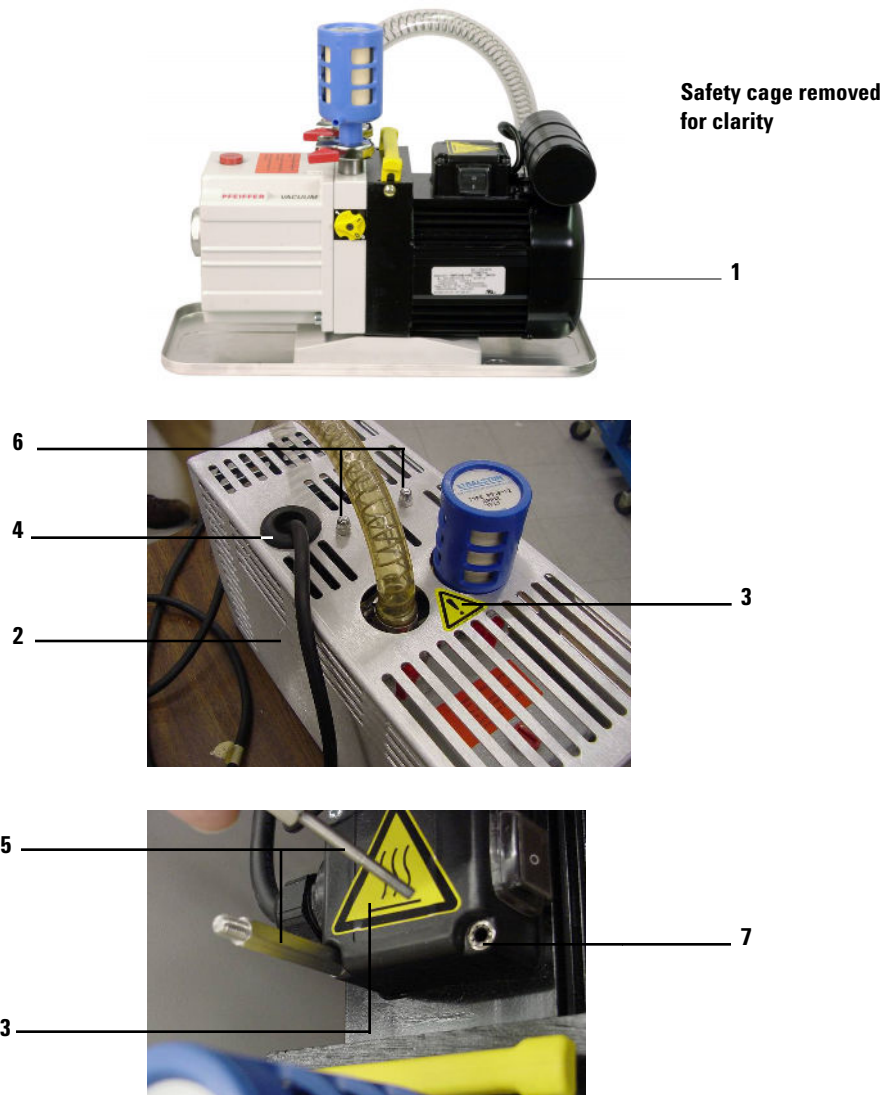

Figure 56 Foreline pump and related parts

Dry foreline pump and related parts

Table 18 Dry foreline pump and related parts (Figure 57)

Description	Part number
Foreline hose assembly (hose and internal spring)	05971-60119
• Hose Clamp* used with 05971-60119	1400-3241
Dry foreline pump	G3170-80028
Dry foreline pump (exchange)	G3170-89028
Foreline pump inlet seal (KF10/16)	0905-1463
KF10/16 Clamp (foreline inlet), Micro-Ion vacuum gauge	0100-1397
KF16 Hose adapter	G1099-20531
KF25 Clamp (tp end of hose – not shown)	0100-0549
KF25 Hose adapter (tp end of hose – not shown)	G1099-20532
Silencer filter	G3170-80030
Exhaust hose	G3170-60100
Exhaust adapter	G3170-80029
Safety cage	G3170-60033

* Hose clamps are interchangeable, but give an optimum fit if they are matched

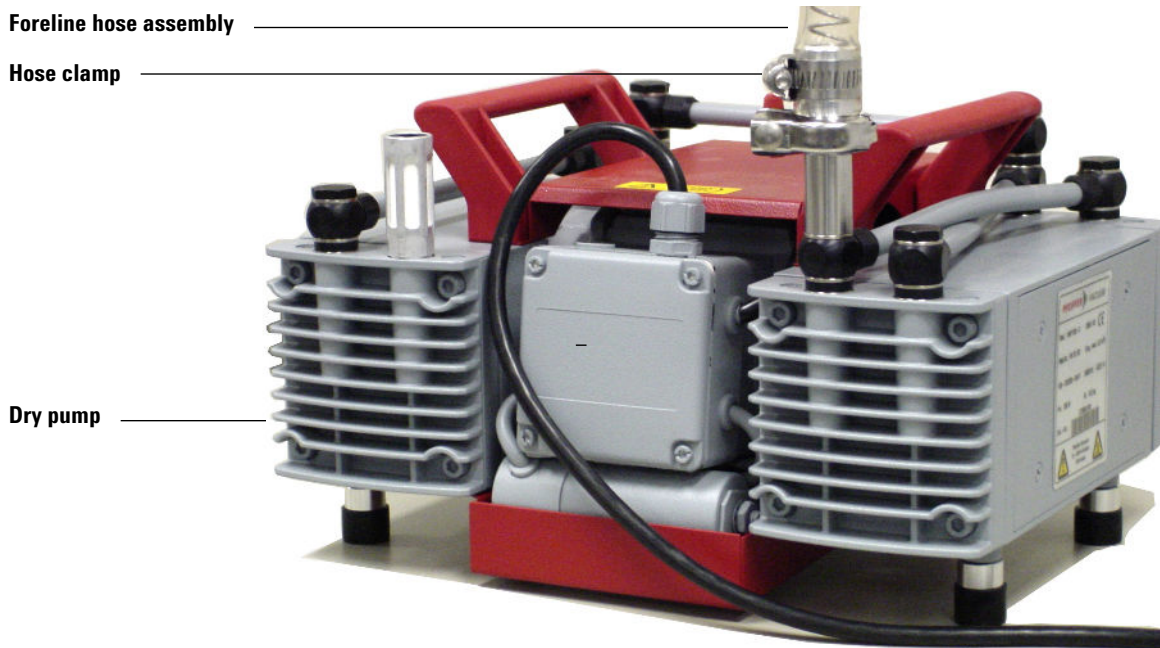

Figure 57 Dry foreline pump and related parts

Diffusion pump and related parts

Table 19 Diffusion pump MSD vacuum system components (Figure 58)

Item	Description	Part number
	Claw clamps for baffle adapter	G3170-60590
1	Diffusion pump	
	120V	G1099-80500
	220/240V	G1099-80501
	Diffusion pump baffle adapter	G1099-20021
	Diffusion pump baffle adapter O-ring	0905-1443
	Diffusion pump control cable	G3170-60437

Table 19 Diffusion pump MSD vacuum system components (Figure 58) (continued)

Item	Description	Part number
	Diffusion pump packaging cap	G3170-40540
2	Fan (for high vacuum pump)	3160-1037
3	Foreline gauge assembly	G1099-60545
	Foreline gauge seal	0905-1463
	KF10/16 clamp (diffusion pump outlet)	0100-1397
	KF10/16 seal (diffusion pump outlet)	0905-1463
	KF50 clamp	0100-1395
	KF50 seal (foreline pump to baffle adapter)	0100-1884
	Side plate (includes feedthroughs and thumbscrews)	G1099-60021
	Analyzer chamber	G3170-20549

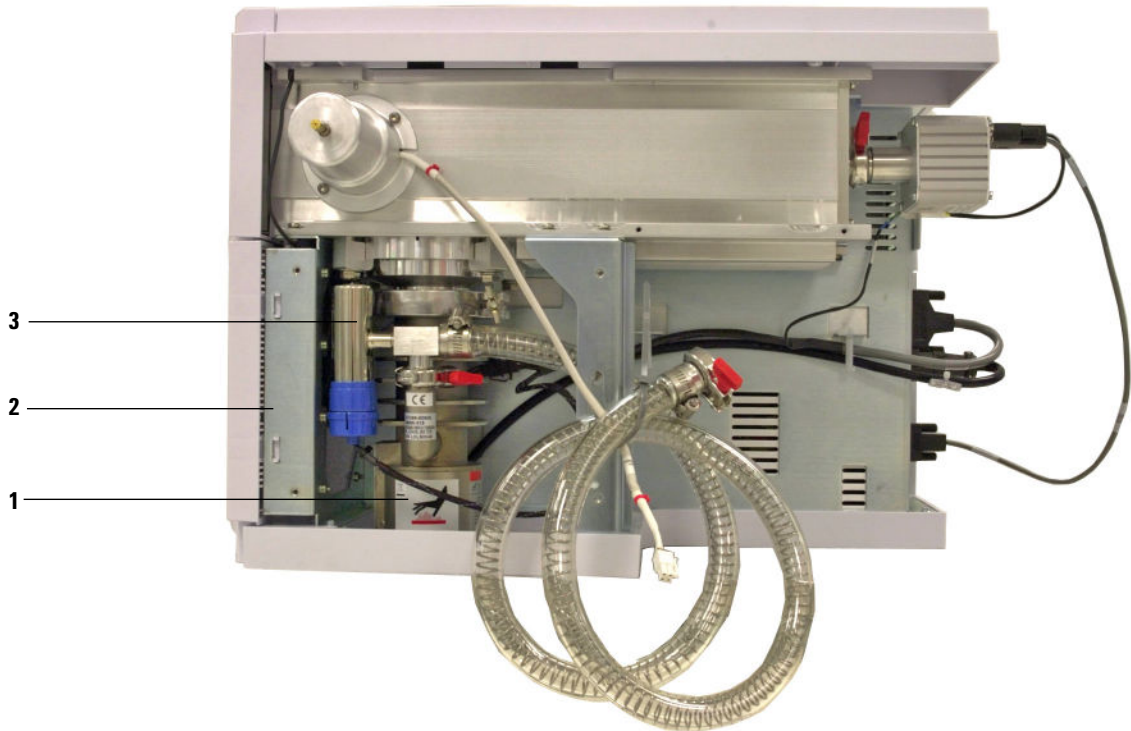

Figure 58 Diffusion pump and related parts

Turbo pump and related parts

Table 20 Turbo pump MSD vacuum system components (Figure 59)

Item	Description	Part number
	Claw clamps for baffle adapter, standard turbo	G3170-60590
	Clamp for vacuum gauging	0100-1397
1	Fan (for high vacuum pump)	G1099-60564
	KF25 clamp (for turbo pump outlet)	0100-0549

Table 20 Turbo pump MSD vacuum system components (Figure 59) (continued)

Item	Description	Part number
	KF25 O-ring assembly (for turbo pump outlet)	0100-1551
4	Micro-Ion Vacuum Gauge vacuum gauging electronics	G3170-80001
2	Performance turbomolecular pump	G3170-89062
2	Standard turbomolecular pump	G3170-89061
	Turbo pump seal with shield	0905-1613
3	Turbo power supply only	G3170-60600
	Turbo separate power supply-control wiring harness	G3170-60835
5	Analyzer chamber (manifold)	G3170-20560
	Manifold EMC gasket	G3170-80031

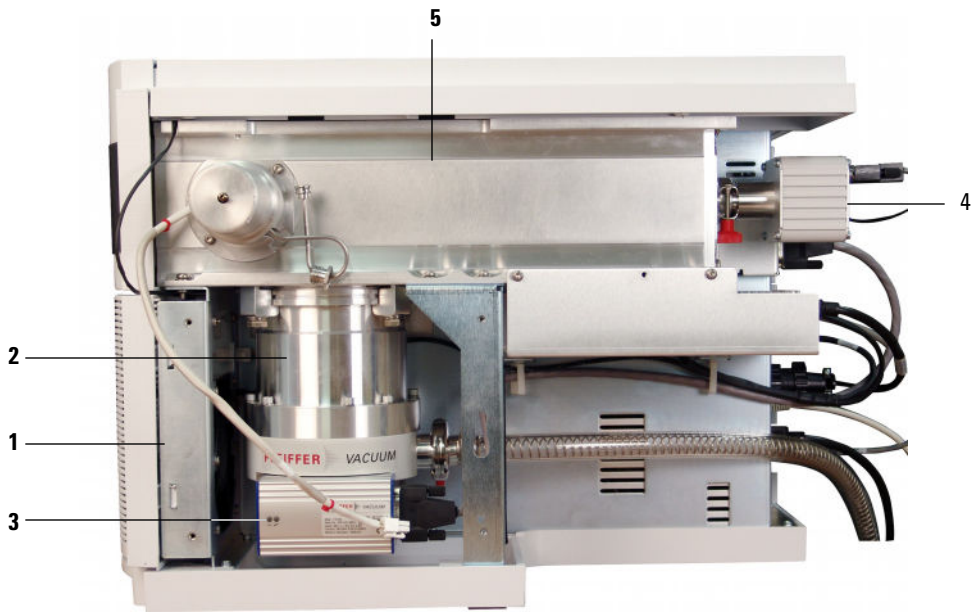

Figure 59 Turbo pump and related parts

Analyzer

Table 21 and Figure 60 show the analyzer chamber and associated parts.

Table 21 Analyzer chamber and related parts (Figure 60)

Item	Description	Part number
1	Shield/plate for ion gauge port	G3170-00003
	Micro-Ion Vacuum Gauge Baffle	G3170-00015
	• M3X12 TX T10 PN SQ Cone SS (qty 2)	0515-0664
2	El Calibration valve assembly	
	Turbo pump MSDs	G3170-60204
	Diffusion pump MSDs	G3170-60201
3	Calibration vial	G3170-80002
4	End plate front glass	G3170-20552
4	End plate front acrylic	G3170-20022
5	End plate front frame	G3170-00001
	End plate rear cap	G3170-20553
	Shield/plate for ion gauge port	G3170-00003
	Side plate (includes feedthrough and thumbscrews)	G3170-60021
6	Vent valve knob	G3170-20554



Figure 60 Analyzer chamber and related parts

Table 22 and Figure 61 show the replacement parts for the analyzer. Analyzer screws (Table 23) and the individual ion source parts (Table 24) are listed in the tables that follow.

Table 22 Analyzer parts (Figure 61)

Item	Description	Part number
	Analyzer, new	
	Turbo	G3170-65775
	Diffusion	G3170-65785
	Analyzer, rebuilt	
	Inert analyzer	G3170-69770
	Standard analyzer	G3170-68780
	Detector, HED	G3170-80100
7	Electron multiplier horn	G3170-80103
	Feedthrough board (source board)	G1099-60425
	HED feedthrough	G1099-80012
	O-ring, Viton for HED feedthrough	0905-0490

Table 22 Analyzer parts (Figure 61) (continued)

Item	Description	Part number
4	El 350 ion source, new	
	Turbo - inert	G3170-65760
	Diffusion - stainless steel	G3170-65750
4	El 350 ion source, rebuilt	
	Turbo - inert	G3170-69760
	Diffusion - stainless steel	G3170-69750
6	Magnet assembly	05971-60160
	Low gauss magnet assembly	G3163-60560
	Mass filter cable kit	G3170-60130
	Mass filter contacts (4)	G1099-60142
	Mass filter canted coil support, detector end	G3170-20025
	Mass filter canted coil spring	G1460-2724
	Mass filter ceramic support, source end	G1099-20123
3	Mass filter heater assembly	G1099-60172
	Mass filter radiator	G3170-20121
	Mounting bracket, detector end	G3170-00040
	Mounting bracket, source end	G1099-00001
	Pins for source and detector end mounting brackets	G1099-20137
	Side plate (includes thumbscrews)	G3170-60021
5	Source radiator	G1099-20122
	Side board, new	G3170-65015
	Side board, rebuilt	G3170-69015
	RFPA fan assembly	G3170-60023
	Quad Stops (need 2)	G3170-20023

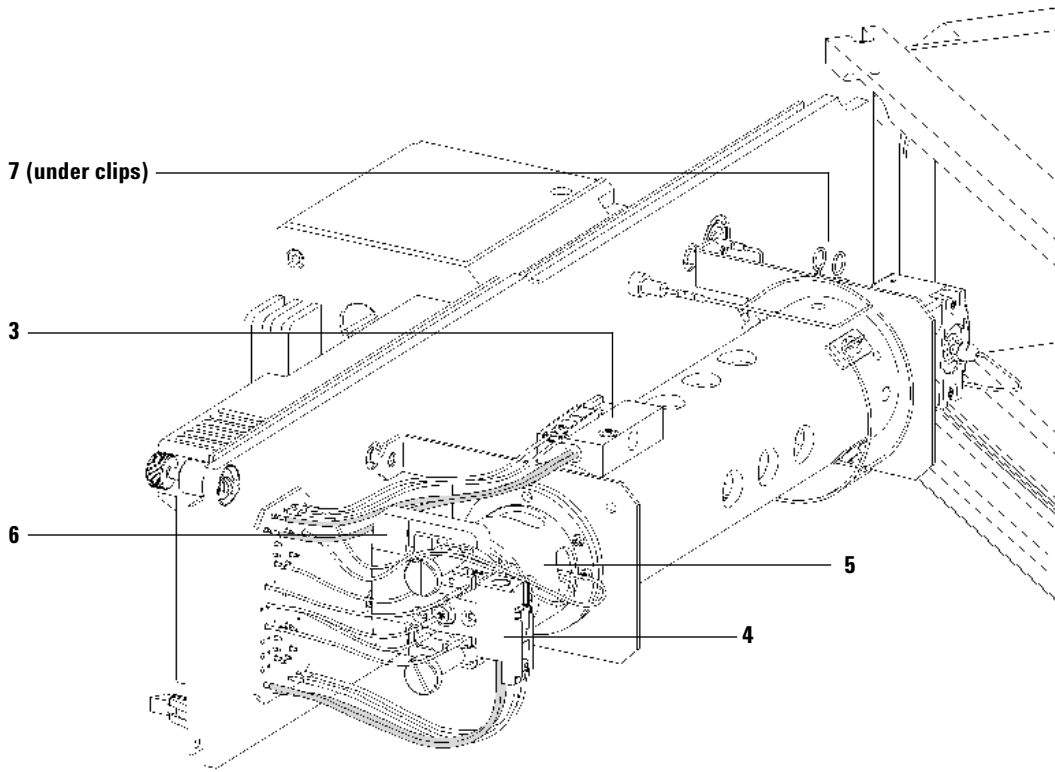

Figure 61 Analyzer parts

Table 23 Analyzer screws

Description	Part number
Heater/Sensor (quad) setscrew	0515-1446
Ion source thumbscrew	G1099-20138
Magnet mounting screws	0515-1046
Screw – magnet bracket to source radiator	0515-1602
Screws – source radiator and detector to quad radiator	G3170-20123
Screws – mass filter contact assembly/heater block	G3170-20122
Screws – radiator. Mounting brackets side board	0515-0430
Source radiator screws	0515-1052
Screws for Quad Stop	0515-0221

El source

Table 24 El ion source (Figure 62)

	Description	Part number
	Ion source, new	
	Turbo - inert	G3170-65760
	Diffusion - stainless steel	G3170-65750
	Ion source, rebuilt	
	Turbo - inert	G3170-69760
	Diffusion - stainless steel	G3170-69750
11	Drawout cyclinder	G1072-20008
12	Drawout plate – 3 mm Inert	G2589-20100
12	Drawout plate - 3 mm Stainless Steel - Standard	05971-20134
12	Drawout plate – 6 mm Inert*	G2589-20045
12	Drawout plate - 6 mm Stainless Steel - RTGA	G3163-20530
9	Entrance lens	G3170-20126
3	El filament	G2590-60053
4	Interface socket	G1099-20136
10	Ion focus lens	05971-20143
8	Lens insulator (one piece)	G3170-20530
5	El 350 Anodized Repeller assembly	G3170-60172
	Inert El 350 Anodized Repeller assembly	G3170-60171
7	Screws for filament	G1999-20021
6	Screw to hold repeller assembly on source	G1999-20021
2	Setscrew for lens stack	G1999-20022
1	Source body - Inert	G2589-20043
1	Source body - Stainless Steel	G1099-20130

* Used in G2860A and G2860B extended linearity kits

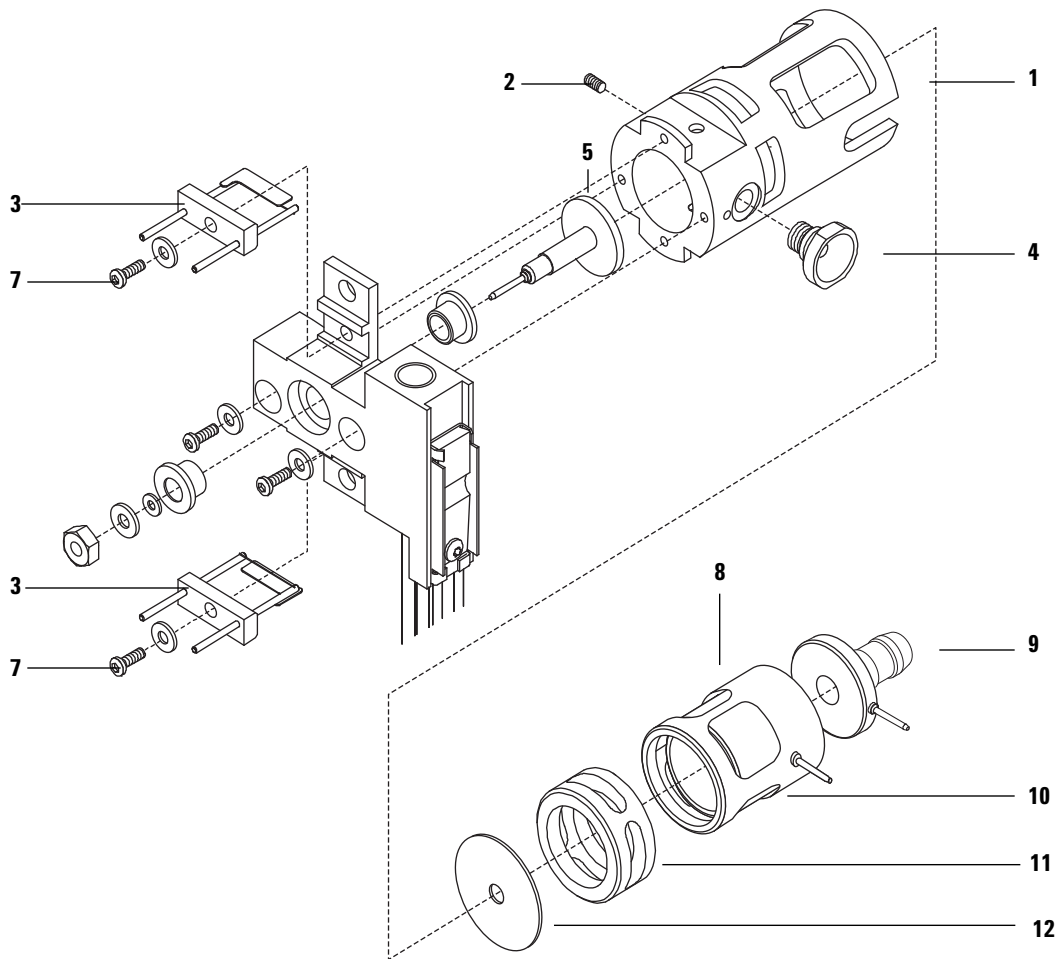

Figure 62 EI source

Repeller assembly

Table 25 Repeller assembly

Description	Part number
EI 350 Anodized Repeller assembly	G3170-60172
Inert EI 350 Anodized Repeller assembly	G3170-60171
Insulator (2 required)	G1099-20133
Nut, 5.5-mm	0535-0071
Repeller - Inert	G2589-20044
Repeller - Stainless Steel	G1099-20132
Setscrew	0515-1446
Anodized Source Heater Assembly	G3169-60177
Washer for repeller	3050-0891

Heater sensor assembly

Table 26 Heater sensor block assembly

Description	Part number
EI 350 Anodized Source Heater Assembly	G3170-60180
Inert EI 350 Anodized Source Heater Assembly	G3170-60177
EI 350 Anodized Source Heater Assembly, Japan	G3170-60178
Inert EI 350 Anodized Source Heater Assembly, Japan	G3170-60179
Setscrew	0515-1446
M3 x 0.56-mm long screw	0515-0430
350 Repeller Block	
Turbo	G3170-20131
Diffusion	G3170-20132
Heater, Repeller	G1099-60103

Table 26 Heater sensor block assembly

Description	Part number
Heater, Repeller, Japan	G3170-60103
High Temp Source Sensor	G3170-60104

EI GC/MSD Interface

Table 27 lists the replacement parts related to the EI GC/MSD interface.

Table 27 EI GC/MSD interface

Description	Part number
GC/MSD interface (complete)	G1099-60300
Interface column nut	05980-20066
Heater sleeve	G1099-20210
Heater/Sensor assembly	G1099-60107
Insulation	G1099-20301
Setscrew for heater/sensor assembly	0515-0236
Screws, M4x0.7 panhead, for heater sleeve	0515-0383
Welded interface assembly	G1099-60301
RTGA Welded interface assembly	G2589-60060
GC/MSD interface O-ring	0905-1405
Interface cover	G1099-00005
Transfer line cover	G3170-00405
Screws for mounting interface and cover to analyzer chamber	0515-0380

Consumables and Maintenance Supplies

This section (Tables 28 through 31) lists parts available for cleaning and maintaining your MSD.

Table 28 El maintenance supplies

Description	Part number
Abrasive paper, 30 µm	5061-5896
Alumina powder, 1 kg	8660-0791
Cloths, clean (qty 300)	05980-60051
Cloths, cleaning (qty 300)	9310-4828
Cotton swabs (qty 100)	5080-5400
Diffusion pump fluid (2 required)	6040-0809
Foreline pump oil, P3, 0.5 L	6040-0621
Gloves, clean – Large	8650-0030
Gloves, clean – Small	8650-0029
Grease, Apiezon L, high vacuum	6040-0289

Table 29 Tools

Description	Part number
Column installation tool	G1099-20030
Funnel	9301-6461
Hex key, 5 mm	8710-1838
Tool Kit	G1099-60566
Ball drivers, 1.5-mm	8710-1570
Ball drivers, 2.0-mm	8710-1804
Ball drivers, 2.5-mm	8710-1681
Hex nut driver, 5.5-mm	8710-1220
Pliers, long-nose (1.5-inch nose)	8710-1094
Screwdrivers Flat-blade, large	8730-0002
Screwdrivers Torx, T-10	8710-1623
Screwdrivers Torx, T-15	8710-1622
Screwdrivers Torx, T-20	8710-1615
MSD Shipping kits	G3170-60501
6850A GC Shipping kits	G4351-60585
6890 GC Shipping kits	G1530-60865
7820A GC Shipping kits	G2570-60201
7890A GC Shipping kits	G3430-60581
Tweezers, non-magnetic	8710-0907
Wrenches, open-end 1/4-inch x 5/16-inch	8710-0510
Wrenches, open-end 10-mm	8710-2353
Wrist strap, antistatic, small	9300-0969
Wrist strap, antistatic, medium	9300-1257
Wrist strap, antistatic, large	9300-0970

Table 30 Ferrules

Description	Part number
For the GC/MSD interface	
• Blank, graphite-vespel	5181-3308
• 0.3-mm id, 85%/15% for 0.10-mm id columns	5062-3507
• 0.4-mm id, 85%/15%, for 0.20 and 0.25-mm id columns	5062-3508
• 0.5-mm id, 85%/15%, for 0.32-mm id columns	5062-3506
• 0.8-mm id, 85%/15%, for 0.53-mm id columns	5062-3538
For the GC inlet	
• 0.27-mm id, 90%/10%, for 0.10-mm id columns	5062-3518
• 0.37-mm id, 90%/10%, for 0.20-mm id columns	5062-3516
• 0.40-mm id, 90%/10%, for 0.25-mm id columns	5181-3323
• 0.47-mm id, 90%/10%, for 0.32-mm id columns	5062-3514
• 0.74-mm id, 90%/10%, for 0.53-mm id columns	5062-3512

Table 31 Miscellaneous EI and CI parts and samples

Description	Part number
EM Horn	G3170-80103
Filament assembly (EI)	G2590-60053
Filament assembly (High temperature EI for GCMS)	G3170-60050
Filament assembly (CI)	G1099-80053
Foreline pump oil (1 liter), P3	6040-0621
Foreline exhaust oil mist trap	G1099-80039
Heater/Sensor GC/MSD interface	G1099-60107
Benzophenone, 100 pg/μL	8500-5400
Octafluoronaphthalene, OFN, 1pg/μL	5188-5348
Octafluoronaphthalene, OFN, 100 fg/μL	5188-5347
PFHT, 100 pg/μL	5188-5357
PFTBA, 10 gram	8500-0656
PFTBA sample kit	05971-60571
PFDTD calibrant	8500-8510
Foreline pump tray	G1099-00015
Eval A, hydrocarbons	05971-60045
Micro-Ion gauge electronics	G3170-89001
Methane/isobutane gas purifier	G1999-80410
J20' 1/8-inch id stainless steel	7157-0210
Wipes (qty 300)	9310-4828
Swagelok ferrule, front, 1/8-inch, 10/package	5180-4110
Swagelok ferrule, rear, 1/8-inch, 10/package	5180-4116
Swagelok nut, for 1/8-inch fitting, 10/package	5180-4104
Swagelok nut and ferrules, 10 set/package	5080-8751
Tubing cutter for SS tubing	8710-1709

Table 31 Miscellaneous EI and CI parts and samples (continued)

Description	Part number
Tubing cutter replacement blades	8710-1710
CI shipping kit	G3170-60505

CI Parts

Tables 32 through 34 and Figures 63 and 64 show parts that may be required to maintain the 5975 Series MSD with CI. The parts in this section are related directly to the CI accessory; other parts for the MSD can be found in the previous sections of this chapter.

Table 32 CI flow control module (Figure 63)

Item	Description	Part number
	CI flow control module*	
1	CI calibration valve assembly	G1999-60452
	PFDTD calibrant	8500-8510
2	Calibration sample vial	G3170-80002
	Sample vial O-ring, 1/4-inch Viton	5180-4182
	Solenoid valve and cable	G1999-60452
	CI cable from SC to CI Flow Module	G3170-60808
	Cable, CI to CI Bulkhead	G3170-60807
	CI Flow control PCA	G3170-60005
3	Mass flow controller	0101-1006
4	Shutoff valve	G1999-80402
	Mass flow controller cable	G1999-60464
5	Reagent gas select valve (Gas A and Gas B)	G1999-80401
	VCR gasket, 1/4-inch	0100-1436
	VCR gasket, 1/8-inch	0100-0468
	Methane/Isobutane gas purifier	G1999-80410
	Stainless steel tubing, 1/8-inch id, 20 feet	7157-0210
	Swagelok ferrule, front, 1/8-inch, 20/package	5180-4110
	Swagelok ferrule, rear, 1/8-inch, 20/package	5180-4116

Table 32 CI flow control module (Figure 63) (continued)

Item	Description	Part number
	Swagelok nut, for 1/8-inch fitting, 20/package	5080-8751
	Swagelok nut and ferrules, 20 sets/package	5080-8751

* Not set up

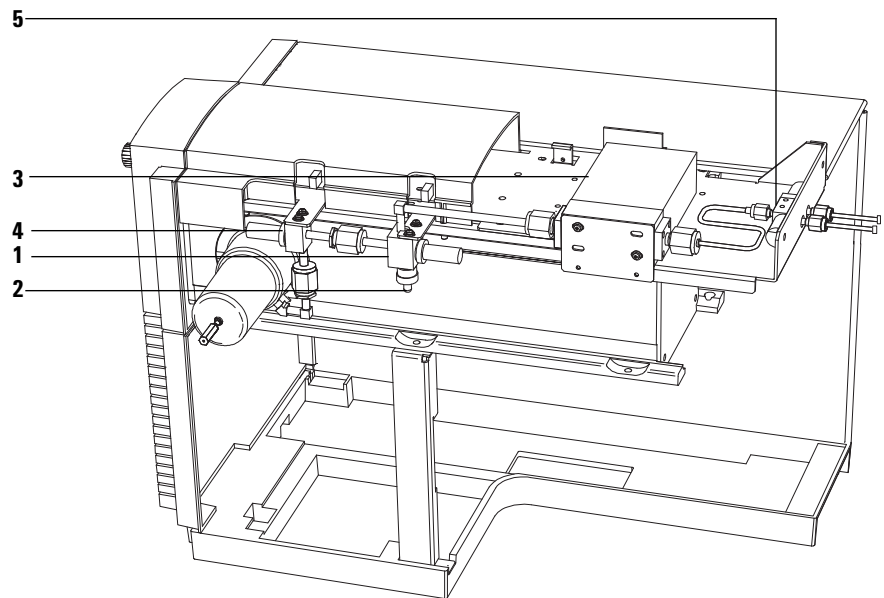

Figure 63 CI flow control module

Table 33 Cl ion source (Figure 64)

Item	Description	Part number
	Box for ion source	G1999-65001
	350 Cl ion source, new	G3170-65403
1	Cl drawout cylinder	G1999-20444
2	Cl drawout plate	G1999-20446
3	Cl filament	G1099-80053
4	Cl heater block	G3170-20431
	350 Cl repeller block	G3170-20133
5	Cl interface tip seal	G1999-60412
6	Cl ion focus lens	G1999-20443
7	Cl lens insulators (pair)	G1999-20445
8	Cl repeller	G1999-20432
9	Cl repeller insulator	G1999-20433
10	Cl source body	G1999-20430
11	350 Cl source heater assembly	G3170-60415
	350 Cl source heater assembly, Japan (300-350)	G3170-60416
12	Dummy filament	G1999-60454
13	Entrance lens	G3170-20126
14	Screw, filaments	G1999-20021
15	Screw, lens stack	G1999-20022
	Screw M3 × 4 mm socket head for RTD	0515-2903
16	Screw M2 × 8 mm mounts source to radiator (not shown)	0515-1046

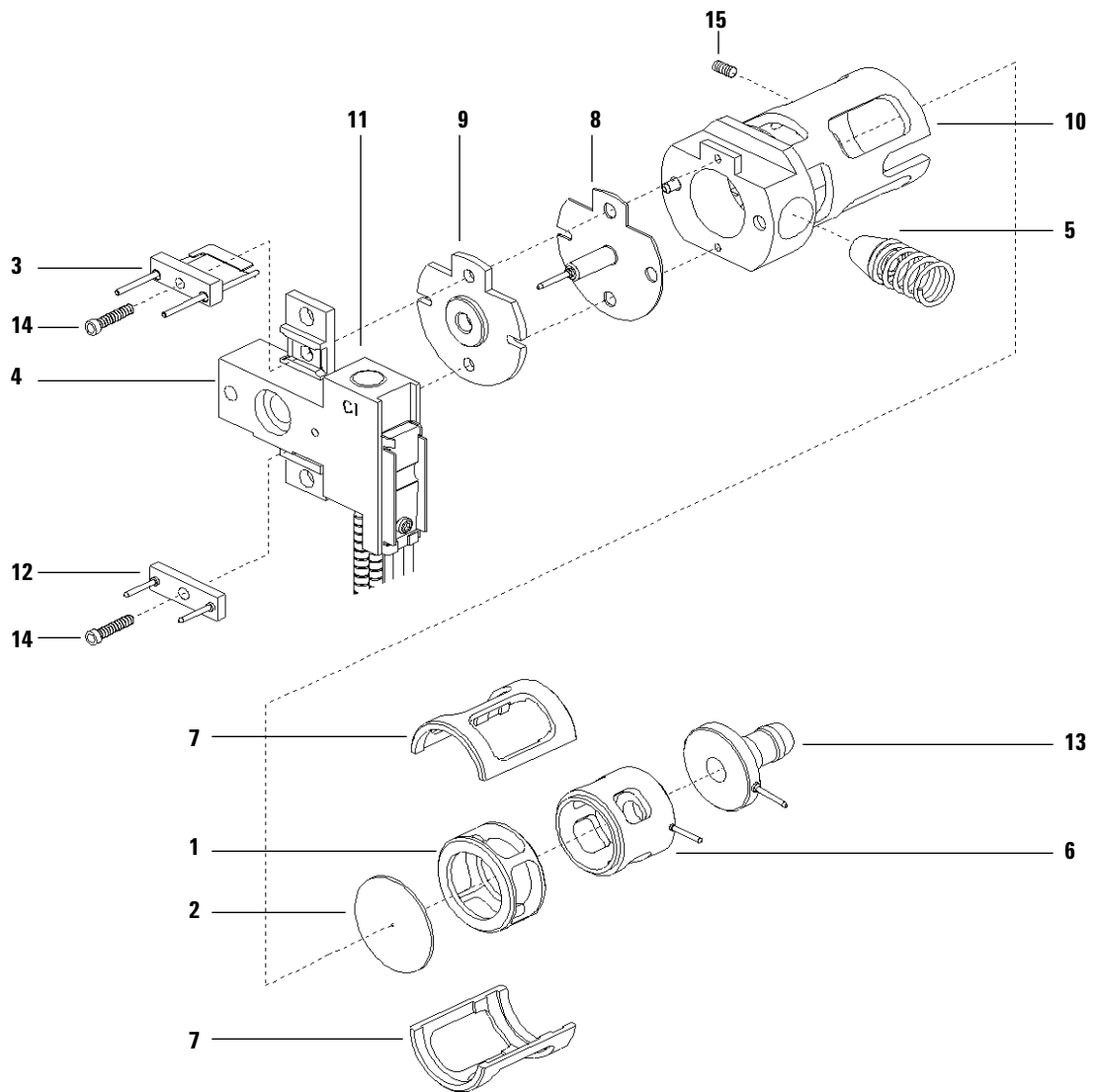

Figure 64 Exploded view of the CI ion source

Table 34 CI GC/MSD interface

Description	Part number
CI GC/MSD interface Assembly	G3170-65400
Heater clamp	G1999-20410
Heater/Sensor assembly	G1099-60107
Transfer line cup (cover)	G3170-00405
Interface insulation	G1999-20401
Screws for heater clamp	0515-0383
Screws to attach interface to manifold	0515-0380
Welded interface	G3170-60401
Interface tip seal	G1999-60412

Index

Numerics

- 19, large peak at m/z , in CI MSD, 75
- 219 width, 209
- 32, visible peak at, in CI MSD, 76

A

- Abrasively cleaning ion source parts, 138
 - parts to be cleaned, 135
- Abundance
 - absolute, 40
 - low for m/z 502, 40
 - relative, 40
- AC board, 220
- Adjusting the RF coils, 159
- Air leaks
 - as a source of contamination, 54
 - finding in CI, 61
 - small enough to cause no problems in
 - PCI can destroy NCI sensitivity, 58
 - visible peak at m/z 32 in CI MSD, 76
- Ammonia
 - ballasting of the foreline pump required due to, 166
- AMU gain, 209
- AMU offset, 209
- Analyzer, 197 to 214
 - basic components of, 198
 - heaters, 213
 - ion source, 200
 - maintaining, 131
 - mass filter, 208
 - part numbers, 250
 - parts that should not be disturbed, 132
 - radiators, 213
- Analyzer chamber pressure
 - too high, 42
 - too low, 43
- Analyzer chamber, turbo pump, 179
- Analyzer temperatures
 - recommended, 213

- Autotune
 - relative abundances of m/z 502 produced by different autotunes, 40

B

- Back panel and connectors, 225
- Background, high, 38, 54
- Baseline, chromatographic
 - falling, 35
 - high, 35
 - rising, 35
 - wandering, 36
- Bleed. *See* Column bleed *or* Septum bleed

C

- Calibrant
 - CI calibrant ions not visible, 73
- Calibrant vial, CI
 - refilling, 169
- Calibrant vial, CI, refilling
- Calibration valve
 - O-ring, 182
- Calibration valve, CI, 192
- Calibration valve, EI
 - reinstalling, 113
- Calibration vial, EI
 - refilling and reinstalling, 112
 - removing, 109
- Carrier gas
 - contaminated, 54
- Chemical ionization
 - hardware overview, 16
- Chemical residue, hazardous, 86
- Chromatography, abnormal results, 33
- CI calibrant vial
 - refilling, 169
- CI calibration valve, 192
- CI filament, 202
- CI interface tip seal, 202
 - installing, 164, 166, 167, 169

- CI ion source
 - repeller, 202
- CI maintenance, 163 to 170
- CI MSD maintenance, 163
 - installing the CI interface tip seal, 164, 166, 167, 169
- CI spectra
 - classical, 16
- Cleanliness, importance during maintenance, 131
- Column bleed
 - as a source of contamination, 54
- Column nut
 - leaking, 53
- Columns
 - installing in the GC/MSD interface, 105, 109, 112, 113, 118, 133, 135, 138, 140, 142, 144, 151, 164, 166, 167, 169, 219
- Compression seals, 183
- Connectors, 225
 - foreline pump cord receptacle, 225
 - high vacuum power (HIVAC POWER), 225
 - high vacuum signal (HIVAC SIGNAL), 225
 - power cord receptacle, 225
 - remote start, 225, 228
- Consumables, part numbers of, 260
- Contamination, 54
 - avoiding after cleaning the ion source, 131

D

- DC polarity, 210
- Detector, 211
 - difficulty with the EM supply, 47
 - electron multiplier horn, 211
 - electron multiplier voltage, 211
 - replacing the horn, 151
 - steadily increasing EM voltage, 212

Index

Detector focus lens, 211
Diffusion pump
 effect of low fluid level in, 42
 error messages related to, 48
Diffusion pump fluid
 as a source of contamination, 54
Drawout plate and cylinder, 206
Drying cleaned ion source parts, 131
Dummy filament, 202

E

EI/CI GC/MSD interface. *See* CI interface

Electronics, 215 to 229
 ac board, 220
 ac-dc board. *See* low voltage power supply
 danger to from electrostatic discharge, 87, 157
 high voltage (HED) power supply, 224
 LAN/MS control card, 223
 locations of major components, 217
 low voltage power supply, 224
 main board, 219
 maintaining, 157
 part numbers, 233
 power supplies, 224
 signal amplifier board, 220
 status display, 217
 toroid transformer, 224

Electrostatic discharge
 danger to the electronics from, 87, 157
 precautions to take against, 132, 157

EM
 See also Detector
 See Electron multiplier

EM voltage, 212
Emission current, 204
 if there is none, 52
End plate O-rings, 182
Entrance lens, 207
Error messages
 difficulty in mass filter electronics, 47
 difficulty with the EM supply, 47
 difficulty with the fan, 47
 difficulty with the HED supply, 48
 difficulty with the high vacuum pump, 48

foreline pressure has exceeded 300 mTorr, 49
internal MS communication fault, 49
 latched, 47
 lens supply fault, 49
 log amplifier ADC error, 49
 no peaks found, 49
 temperature control disabled, 50
 temperature control fault, 50
 the high vacuum pump is not ready, 51
 the system is in standby, 51
 the system is in vent state, 51
 there is no emission current, 52
 there is not enough signal to begin tune, 52
 translating error numbers into messages, 47

ESD. *See* Electrostatic discharge

Excessive noise or low signal-to-noise ratio in CI MSD, 74

Exhaust
 oil trap for foreline pump, 175

F

Face seals, 182
Fan, for high vacuum pump, 191
 incorrect operation of, 47
 replacing, 114

Filaments, 204
 care, 205
 electron energy, 204
 emission current, 204
 parameters affecting, 204
 reinstalling, 144
 selection, 204

Foreline pressure
 exceeding 300 mTorr, 49
 too high, 42
 too low, 43

Foreline pump, 175
 effect of low oil level, 42
 failure to turn on, 32
 incorrect operation, 32
 minimizing damage from ammonia reagent gas, 166
 power cord receptacle, 225
 turned off during pumpdown, 32
 venting the exhaust, 86

See also Foreline pump oil

Foreline pump oil
 draining, 98
 refilling the pump with, 100
 replace every 6 months, 84

Foreline pump power cord receptacle, 225

Foreline trap. *See* Oil trap

Front panel. *See* Status Display

Fuses
 on the back panel, 225
 replacing the primary fuses, 161

G

Gas purifier, methane/isobutane replacing, 167

Gauge controller
 abnormal or blank display, 43
 indicated vs. actual pressure, 195
 power indicator does not light, 44

GC
 components responsible for air leaks, 53
 does not turn on, 31
 sources of contamination in, 54

GC interface. *See* GC/MSD interface

GC/MSD interface
 failure to heat up, 46
 maintaining, 153
 reinstalling a heater and sensor, 156
 removing the heater and sensor, 154

Grounded wrist strap, 87

H

Half-splitting, to find air leaks in CI MSD, 62

Heaters
 GC/MSD interface, reinstalling, 156
 GC/MSD interface, removing, 154
 ion source, reinstalling, 147
 ion source, removing, 145
 mass filter, reinstalling, 149
 mass filter, removing, 148

HED, 211
 difficulty with the HED power supply, 48

HED feedthrough seal, 183

HED power supply, 224
 High electron multiplier voltage in CI MSD, 79
 High energy dynode. *See* HED
 High vacuum gauge
 installing, 117
 removing, 116
 High vacuum pump
 difficulty with, 48
 not ready, 51
 High voltage feedthrough. *See* HED feedthrough
 Horn, electron multiplier, 211

I

Indicated pressure, 195
 Interface socket
 reinstalling, 140
 removing, 133
 Interface tip seal, CI
 installing, 164, 166, 167, 169
 Interfacing to external devices, 228
 start run input, 229
 system ready signal, 228
 Ion focus, 206
 Ion source, 200
 body, 200
 cleaning, 133, 135
 drawout plate and cylinder, 206
 drying cleaned parts, 138
 entrance lens, 207
 filament care, 205
 filament, reinstalling, 144
 filaments, 204
 heater, 213
 heater and sensor, reinstalling, 147
 heater and sensor, removing, 145
 ion focus lens, 206
 magnet, 206
 parts that should not be cleaned, 135
 reassembling, 135, 138, 140, 142
 removing, 118
 repeller, 206
 Ion source, CI. *See* CI ion source

K

KF seals, 182

L

LAN (I/O) connector, 226
 LAN/MS control card, 223
 interfacing to external devices, 228
 RAM on, 223
 remote control processor, 228
 Line voltage
 symptoms of incorrect or missing, 31, 43
 Local Control panel, 13
 Log amplifier. *See* Signal amplifier
 Low sensitivity
 at high masses, 41
 general, 37
 Low signal-to-noise ratio in CI MSD, 74
 Low voltage (ac-dc) power supply, 224
 Lubricating
 side plate O-ring, 118

M

m/z, 208
m/z 14 and 16, symptoms of a large air leak, 39
m/z 18, 28, 32, and 44, symptoms of an air leak, 39
m/z 502, low or decreasing abundance of, 40
 Maintenance, 83 to 162
 analyzer, 131
 avoiding dangerous voltages during, 85
 calibration vial, removing, 109
 CI calibrant vial refilling, 169
 CI gas purifier replacing, 167
 CI interface tip seal installing, 164, 166, 167, 169
 CI ion source cleaning, 164
 CI MSD, 163
 cleaning reagent gas supply tubing, 168
 dangerous voltages, 85
 dangerously hot parts, 86
 EI calibration valve, refilling, 113
 EI calibration vial, refilling, 112
 EI calibration vial, reinstalling, 112
 electron multiplier horn, replacing, 151
 electronics, 157
 fan, high vacuum pump, replacing, 114
 filament, reinstalling, 144
 foreline pump in CI, 166
 foreline pump oil, draining, 98
 foreline pump, refilling, 100
 GC/MSD interface, 153
 GC/MSD interface heater and sensor, reinstalling, 156
 GC/MSD interface heater and sensor, removing, 154
 ion source heater and sensor, reinstalling, 147
 ion source heater and sensor, removing, 145
 ion source, reassembling, 135, 138, 140, 142
 ion source, removing, 118
 mass filter (quadrupole), 210
 mass filter heater and sensor, reinstalling, 149
 mass filter heater and sensor, removing, 148
 methane/isobutane gas purifier, 167
 micro-ion vacuum gauge, reinstalling, 117
 micro-ion vacuum gauge, removing, 116
 primary fuses, replacing, 161
 reconnecting the MSD to the GC, 105
 refilling the CI calibrant vial, 169
 RF coils, adjusting, 159
 safety during, 85
 schedule, 84
 separating the MSD from the GC, 101
 side plate O-ring, lubricating, 118
 Malfunctions. *See* Symptoms of malfunctions
 Mass assignments, incorrect, 39
 Mass filter
 219 width, 209
 amu gain, 209
 amu offset, 209
 dc polarity, 210
 dc voltage, 208
 difficulty with the mass filter electronics, 47
 heater, 213
 heater and sensor, reinstalling, 149
 heater and sensor, removing, 148
 maintenance, 210

Index

- mass (axis) offset, 210
- parameters, 208
- radiator, 213
- RF voltage, 208
- Mass gain, 210
- Mass offset, 210
- Mass spectra
 - high abundances at m/z 18, 28, 32, and 44 or at m/z 14 and 16, 39
 - high background, 38
 - inconsistent peak widths, 39
 - incorrect mass assignments, 39
 - isotopes missing or ratios are incorrect, 38
 - precursors, 39
- Mass-to-charge ratio, 208
- Methane/isobutane gas purifier
 - replacing, 167
- Micro-ion vacuum gauge
 - ignition of hydrogen by, 195
 - reinstalling, 117
 - removing, 116
- Miss filter, for foreline exhaust, 176
- Moving the MSD, 94
- MS error numbers, 47
- MSD
 - dangerous voltages in, 85
 - dangerously hot parts in the, 86
 - does not turn on, 31
 - electronics, 215 to 229
 - hazards from chemical residue, 86
 - interfacing to external devices, 228
 - maintaining, 83 to ??
 - moving or storing, 94
 - troubleshooting, 29 to 54
- N**
- NH₃, preventing damage to the foreline pump due to, 166
- No peaks in CI MSD, 69
- O**
- Oil drip tray, for foreline pump, 176
- Oil trap, 176
- Oil tray, for foreline pump, 176
- On/off switch. *See* Power switch
- Ordering parts, 232
- O-rings and O-ring assemblies, 182
- P**
- Parts, 231
 - analyzer, 250
 - consumables, 260
 - electronic, 233
 - if you cannot find a part you need, 232
 - ordering, 232
 - rebuilt assemblies, 232
 - vacuum system, 240
- Parts, replacement, 231
- Peak widths, inconsistent, 39
- Peaks
 - at m/z 18, 28, 32, and 44 or at m/z 14 and 16, 39
 - flat tops, 34
 - fronting, 34
 - inconsistent widths, 39
 - missing, 33, 49
 - precursors, 39
 - split tops, 35
 - tailing, 34
- PFDTD
 - not visible, but reagent ions are present, 73
- PFDTD (perfluoro-5,8-dimethyl-3,6,9-trioxidodecane), 192
- PFTBA (perfluorotributylamine), 192
- Physical description of MSD, 13
- Polarity (dc), of the mass filter, 210
- Power cord
 - ac, 225
 - foreline pump, 225
 - receptacle, 225
- Power supplies
 - high voltage (HED), 224
 - low voltage (ac-dc), 224
- Power switch, 217
- Pressure
 - analyzer chamber pressure too high, 42
 - analyzer chamber pressure too low, 43
 - CI ion source, 202
 - does not change when reagent gas flow is changed, 67
 - foreline pressure too high, 42
 - foreline pressure too low, 43
- Ion source, for CI, 16
- symptoms indicating malfunctions, 42
- too high in analyzer chamber with reagent gas flow, 66
- too high in analyzer chamber without reagent gas flow, 65
- Procedure, 166
- Pump
 - exhaust, venting, 86
- Pump oil drip tray, 176
- Pump, foreline
 - failure to turn on, 32
 - turned off during pumpdown, 32
- Pumpdown
 - failure, 222
 - safety shutdown, 174
- Pumpdown safety shutdown, 222
- Pumping problem, 222
- Pumps turned off, 174, 222
- Q**
- Quadrupole. *See* Mass filter
- R**
- Radiators, 213
- Reagent gas
 - cleaning supply tubing, 168
- Reagent gas ions
 - not visible, 71
- Relative abundance, 40
- Remote start connector, 225, 228
- Repeatability, poor, 37
- Repeller, CI, 202
- S**
- Safety
 - covers, 85
 - during maintenance, 85 to 87
- Seals
 - vacuum, 182
 - See also* O-rings and O-ring assemblies
- Sensitivity
 - poor, 37
 - poor at high masses, 41
- Septum bleed, as a source of contamination, 54

- Septum, leaking, **53**
- Side plate
- lubricating the O-ring, **118**
 - O-ring, **182**
 - thumbscrews, **180**
- Signal amplifier board, **220**
- Signal, not enough to begin tune, **52**
- Smartcard III. *See* LAN/MS control card
- Solvent peak
- effect if analyzer is on, **47, 48**
 - effect on vacuum gauge, **43**
- Startup
- failure of the MSD to, **31**
 - See also* Pumpdown
- Static discharge. *See* Electrostatic discharge
- Status display, **217**
- Storing the MSD, **94**
- Switch, power. *See* Power switch
- Switching, between EI and CI, **17**
- Symptoms of malfunctions
- analyzer chamber pressure is too high, **42**
 - baseline is falling, **35**
 - baseline is high, **35**
 - baseline is rising, **35**
 - baseline wanders, **36**
 - can not complete CI autotune, **80**
 - chromatographic symptoms, **33 to 37**
 - difficulty in mass filter electronics, **47**
 - difficulty with the EM supply, **47**
 - difficulty with the fan, **47**
 - difficulty with the HED supply, **48**
 - difficulty with the high vacuum pump, **48**
 - error messages, **47 to 52**
 - excessive noise or low signal-to-noise ratio in CI MSD, **74**
 - foreline pressure has exceeded 300 mTorr, **49**
 - foreline pressure is too high, **42**
 - foreline pressure is too low, **43**
 - foreline pump is not operating, **32**
 - gauge controller displays 9.9+9 and then goes blank, **43**
 - GC does not turn on, **31**
 - GC/MSD interface will not heat up, **46**
 - general symptoms, **31 to 33**
 - high abundances at m/z 18, 28, 32, 44 or at m/z 14 and 16, **39**
 - high analyzer chamber pressure with reagent gas flow, **66**
 - high background, **38**
 - high electron multiplier voltage in CI MSD, **79**
 - high mass sensitivity is poor, **41**
 - internal MS communication fault, **49**
 - ion source will not heat up, **45**
 - isotopes missing or ratios are incorrect, **38**
 - large peak at m/z 19 in CI MSD, **75**
 - lens supply fault, **49**
 - log amplifier ADC error, **49**
 - mass filter (quad) heater will not heat up, **45**
 - mass spectral symptoms, **38 to 41**
 - MSD does not turn on, **31**
 - MSD is on but foreline pump is not running, **32**
 - no or low PFDTD signal, but reagent ions are normal, **73**
 - no or low reagent gas signal, **71**
 - no peaks, **33, 49**
 - no peaks in CI MSD, **69**
 - peak at m/z 32 in CI MSD, **76**
 - peak widths are inconsistent, **39**
 - peak widths are unstable in CI MSD, **81**
 - peaks are fronting, **34**
 - peaks are tailing, **34**
 - peaks have flat tops, **34**
 - peaks have precursors, **39**
 - peaks have split tops, **35**
 - poor repeatability, **37**
 - poor sensitivity, **37**
 - poor vacuum without reagent gas flow, **65**
 - power indicator on the gauge controller does not light, **44**
 - pressure does not change when reagent gas flow is changed, **67**
 - pressure symptoms, **42 to 44**
 - pressure-related symptoms, overview (CI), **64**
 - reagent gas ion ratio is difficult to adjust or unstable, **78**
 - relative abundance of m/z 502 less than 3%, **40**
 - retention time drifts (all peaks), **36**
 - signal-related symptoms, overview, **68**
 - temperature control disabled, **50**
 - temperature control fault, **50**
 - temperature symptoms, **45 to 46**
 - the high vacuum pump is not ready, **51**
 - the system is in standby, **51**
 - the system is in vent state, **51**
 - there is no emission current, **52**
 - tuning-related symptoms overview for CI MSD, **77**
- System ready signal, **228**
- ## T
- Temperature sensors
- GC/MSD interface, reinstalling, **156**
 - GC/MSD interface, removing, **154**
 - ion source, reinstalling, **147**
 - ion source, removing, **145**
 - mass filter, reinstalling, **149**
 - mass filter, removing, **148**
- Thermal equilibrium, time to reach, **213**
- Toroid transformer, **224**
- Transformer, toroid, **224**
- Troubleshooting, **29 to 54, 57**
- air leaks, determining presence of leak, **60**
 - air leaks, finding location of leak, **61**
 - common CI-specific problems, **58**
 - See also* Symptoms of malfunctions tips and tricks, **30, 59**
- Tuning
- cannot begin, **52**
 - compound, **192**
- Turn on
- failure of the MSD to, **31**
- ## U
- Ultrasonic cleaning of ion source parts, **138**
- ## V
- Vacuum manifold
- turbo pump version, **179**

Index

Vacuum seals, [182](#)
Vacuum system, [171](#)
 part numbers, [240](#)
 turbo pump system overview, [178](#)
Valve
 CI calibration, [192](#)
Voltages, dangerous, [85](#)

W

Water
 detecting in CI, [75](#)
Wid219 parameter, [209](#)
Wiring, dangerous voltages on, [85](#)