

Agilent 7890B Gas Chromatograph

Installation and First Startup

Notices

© Agilent Technologies, Inc. 2015

No part of this manual may be reproduced in any form or by any means (including electronic storage and retrieval or translation into a foreign language) without prior agreement and written consent from Agilent Technologies, Inc. as governed by United States and international copyright laws.

Manual Part Number

G3430-90056

Edition

Third edition, October 2015
Second edition, December 2013
First edition, January 2013

Printed in USA

Agilent Technologies, Inc.
2850 Centerville Road
Wilmington, DE 19808-1610 USA

安捷伦科技（上海）有限公司
上海市浦东新区外高桥保税区
英伦路 412 号
联系电话：（800）820 3278

Warranty

The material contained in this document is provided "as is," and is subject to being changed, without notice, in future editions. Further, to the maximum extent permitted by applicable law, Agilent disclaims all warranties, either express or implied, with regard to this manual and any information contained herein, including but not limited to the implied warranties of merchantability and fitness for a particular purpose. Agilent shall not be liable for errors or for incidental or consequential damages in connection with the furnishing, use, or performance of this document or of any information contained herein. Should Agilent and the user have a separate written agreement with warranty terms covering the material in this document that conflict with these terms, the warranty terms in the separate agreement shall control.

Safety Notices

WARNING

A **WARNING** notice denotes a hazard. It calls attention to an operating procedure, practice, or the like that, if not correctly performed or adhered to, could result in personal injury or death. Do not proceed beyond a **WARNING** notice until the indicated conditions are fully understood and met.

CAUTION

A **CAUTION** notice denotes a hazard. It calls attention to an operating procedure, practice, or the like that, if not correctly performed or adhered to, could result in damage to the product or loss of important data. Do not proceed beyond a **CAUTION** notice until the indicated conditions are fully understood and met.

Contents

1 Installing the GC

Overview of Installation	8
Purpose of this procedure	8
Customer responsibilities	8
About Agilent's installation service	8
Tools and additional parts required	9
Performing checkout	9
System installation	9
The 7890B GC	11
Unpacking	12
Step 1. Place the GC on the bench	13
Step 2. Verify line voltage, voltage settings, and power cord.	14
Power consumption	14
Power cords available	15
Grounding	19
Line voltage	19
Line power cord terminations	19
Step 3. Connect the power cord and turn on the GC	20
Step 4. Connect gases and traps	22
Install the gas regulators	22
Connect the tubing to the gas source	24
Install traps	25
Supplied fittings	26
Plumb to EPC flow modules	26
Install Aux EPC module frits for your application	30
Install hydrogen sensor calibration gas	31
Step 5. Leak test all connections and set source pressures	33
Set source gas pressures	35
Step 6. Vent μ ECD or uncombusted hydrogen to a fume hood	36
Step 7. Connect cryogenic cooling (if present)	37
Connecting liquid carbon dioxide	38
Connecting liquid nitrogen	40
Connecting air to the multimode inlet	41
Step 8. Connect valve actuator air (if present)	42
Step 9. Install inlet checkout parts	43
Step 10. Install ALS, if ordered	44

Step 11. Connect the external cables	45
Back panel connectors	45
Connecting cables	48
Labeling BCD and EVENT cables	50
Configuring the GC IP address	50
GC / MS / Agilent data system / ALS	52
Additional cabling configurations	52
Step 12. Finish configuring communications	53
Configuring GC-MS communications (5977A, 7000C, 7010)	53
Configuring GC-MS communications (5877B)	56
Configuring GC-HS communications	56
Step 13. Calibrate the Hydrogen Sensor	58
Step 14. Configure the date/time, pressure units, and the checkout column	59
Date and time	59
Pressure units	59
Checkout column	59
Step 15. Install the checkout column to the inlet and condition	61
Step 16. Bakeout the detector	63
Step 17. Cool the detector and complete column installation	64
Step 18. If appropriate, update firmware	65
GC firmware	65
PIDs	66
Step 19. Transfer the checkout sample to a screw-top sample vial	67
Step 20. When the system stabilizes, run one injection	68
Step 21. Evaluate Results	69
Prepare for the Next Analysis	70

A Making Swagelok Connections

Making Swagelok Connections	72
Using a Swagelok Tee	75

B Cabling Diagrams and Remote Start/Stop

Using the Remote Start/Stop Cable	78
Connecting Agilent products	78
Connecting non-Agilent products	78
Multi-instrument Cabling Examples	81
GC / ALS / Non-Agilent Data System	81
GC / 3395A/3396B Integrator / ALS	82
GC / 3396C Integrator / ALS	83
Example: Using a Y-Cable in a setup (GC/MSD/Data System/Headspace Sampler)	84
GC / External Events (unspecified, non-Agilent instrument)	85
Cable Diagrams	86
Analog signal cable, general use, G1530-60560	86
Agilent analog signal cable, G1530-60570	87
Remote start/stop cable, general use, 35900-60670	87
Agilent APG remote start/stop cable, 03396-61010	88
Agilent APG remote start/stop cable, G1530-60930	89
Agilent remote start/stop Y-cable, G1530-61200	89
BCD cable, G1530-60590	90
BCD cable, G1530-61100	91
External event cable, G1530-60590	92
External valve cable, G1580-60710	93
Pulser module power supply cable, G1580-60730	94



1 Installing the GC

Overview of Installation	8
The 7890B GC	11
Unpacking	12
Step 1. Place the GC on the bench	13
Step 2. Verify line voltage, voltage settings, and power cord.	14
Step 3. Connect the power cord and turn on the GC	20
Step 4. Connect gases and traps	22
Step 5. Leak test all connections and set source pressures	33
Step 6. Vent μ ECD or uncombusted hydrogen to a fume hood	36
Step 7. Connect cryogenic cooling (if present)	37
Step 8. Connect valve actuator air (if present)	42
Step 9. Install inlet checkout parts	43
Step 10. Install ALS, if ordered	44
Step 11. Connect the external cables	45
Step 12. Finish configuring communications	53
Step 13. Calibrate the Hydrogen Sensor	58
Step 14. Configure the date/time, pressure units, and the checkout column	59
Step 15. Install the checkout column to the inlet and condition	61
Step 16. Bakeout the detector	63
Step 17. Cool the detector and complete column installation	64
Step 18. If appropriate, update firmware	65
Step 19. Transfer the checkout sample to a screw-top sample vial	67
Step 20. When the system stabilizes, run one injection	68
Step 21. Evaluate Results	69
Prepare for the Next Analysis	70

This section contains installation procedures for the Agilent 7890B GC. Depending on the ordered options, some steps are optional, such as plumbing cryogenic cooling or valve actuator air.

Instructions for connecting cables from the GC to other instruments in a typical 7890 Series system are included here and in [Appendix B](#), "Cabling Diagrams and Remote Start/Stop."



Overview of Installation

Purpose of this procedure

This procedure ensures that instruments and systems are installed and functioning as designed. Correct installation is the first step in ensuring that instruments and systems operate reliably over their lifetime.

Customer responsibilities

- 1 Make sure your site meets the basic requirements, including the necessary space, electrical outlets, gases, tubing, operating supplies, consumables and other usage-dependent items required for a successful installation. Refer to the [Agilent GC, GC/MS, and ALS Site Preparation Guide](#).
- 2 If Agilent is delivering installation and familiarization services, users of the instrument should be present throughout these services; otherwise, these users will miss important operational, maintenance, and safety information.

Additional information is included with the Agilent *GC and GC/MS User Manuals & Tools* DVD.

If your site complies with all site preparation specifications, the average installation time for the GC is about 2 hours. Allow more time for any additional products (for example, an ALS), add-ons, and software.

About Agilent's installation service

The installation service does not include:

- Network setup with other computers or to the site or building LAN.
- Customization of the system.
- Method development and testing.
- Analysis of customer standards or samples.
- Testing against the instrument performance specification. (Operational qualification and performance verification services, OQ/PV, can be purchased separately.)

If you need assistance beyond this installation service, please contact your local Agilent Technologies office. Assistance with installation and with user-specific services and applications is available and will be contracted separately.

Tools and additional parts required

Installation requires the following tools, fittings, and hardware. **These items are not included with the instrument.**

- Precleaned copper tubing, 1/8-inch or 1/4-inch od.
- Fittings.
- Tubing cutter.
- Filters for gas supplies.
- 7/16-inch and 9/16-inch wrenches for assembling Swagelok fittings.
- Carrier and other gas supplies.
- Pressure regulator for each gas supply.
- A computer with a LAN connection (for reading GC documentation and for updating GC firmware if needed).
- Any additional LAN components, such as cables and a switch or hub, for connection to the site LAN (not included in Agilent installation services).

The [Agilent GC, GC/MS, and ALS Site Preparation Guide](#) contains a listing of Agilent installation kits and a description of parts included with each. These kits contain filters, fittings, tubing, tools (wrenches, tubing cutter, drivers, and so on), and other required parts for installing a GC.)

Performing checkout

Checkout requires a system that can produce a chromatogram.

- If using an Agilent data system, you can use it to perform the checkout procedure. Read these GC installation instructions and the instructions for installing the data system.
- If an Agilent data system is not available, you can also perform checkout using the Agilent Instrument Utilities software. Install the software on a PC, then read its help topics to learn how to connect to the GC and how to launch the checkout procedures.
- If connected only to an integrator or site system (for example, a LIMS system) that captures the GC output signal, you must connect to that system to obtain the chromatogram.

System installation

If installing an ALS, the ALS can be used for checkout. Also

refer to the ALS installation documentation.

When installed as part of a complete system including an Agilent data system (for example, Agilent OpenLAB CDS), first install the GC through the checkout column bakeout step. Once the bakeout ends, configure the new GC in the data system and open the online instrument session. Use the data system to perform the checkout test.

When installed as part of other complete systems, for example in an Agilent GC/MSD or GC/MS system, see the installation instructions for that system.

The 7890B GC

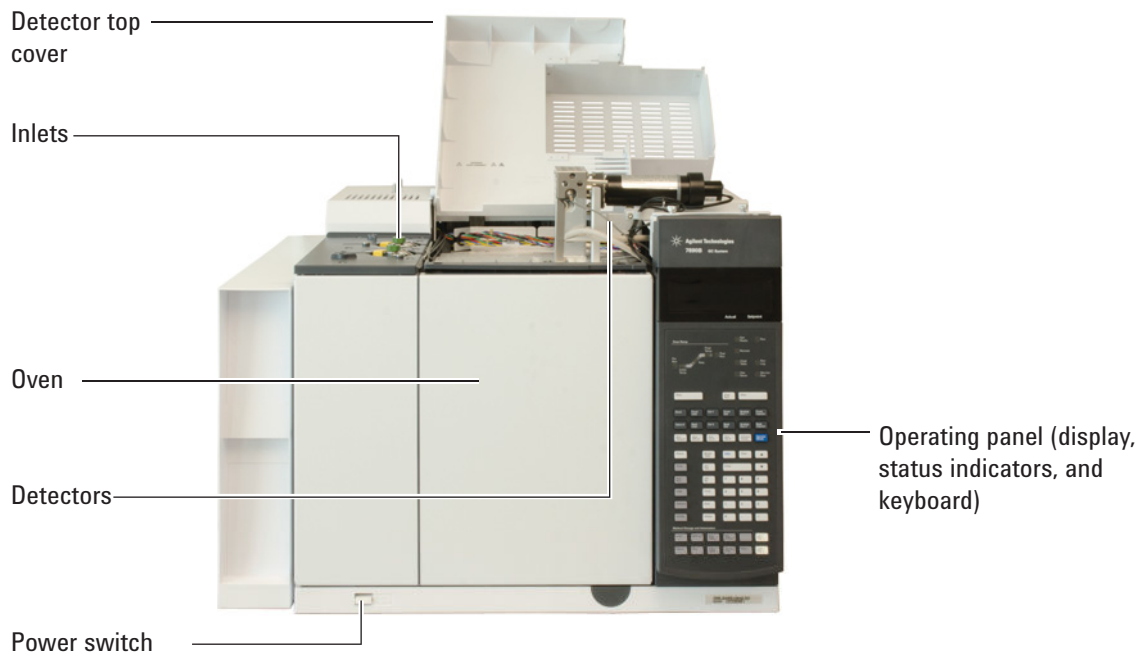


Figure 1 Front of the 7890B GC

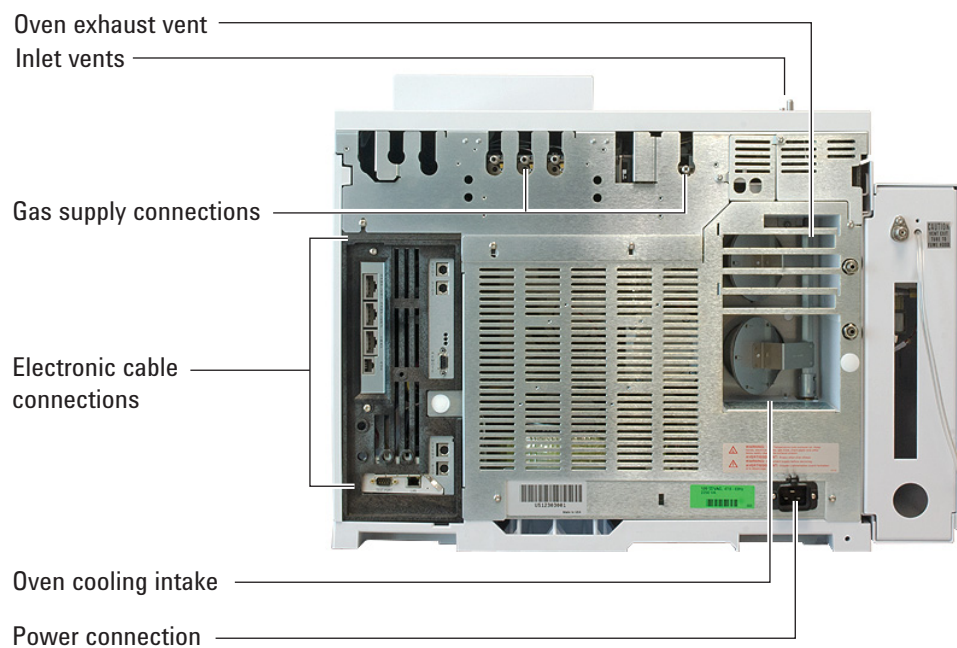


Figure 2 Back of the 7890B GC

Unpacking

- 1 Inspect the shipping containers for damage. If a container is damaged or shows signs of stress, notify both the carrier and your local Agilent sales office.

Keep all shipping materials for inspection by the carrier.

- 2 Check the items received against the packing lists. If there are discrepancies, notify your local Agilent sales office immediately.

Keep the shipping containers until you have checked their contents for completeness and verified instrument performance.

- 3 Remove caps and packing.

Some detectors may have protective caps for shipping. Remove these caps. If equipped with a side-mounted detector, remove the left side panel to gain access to the detector vent cap.

Open the oven door. Remove any packing from inside the oven.

Step 1. Place the GC on the bench

The GC requires a bench that can support its weight plus that of other equipment you will use with it. The area must be free of overhanging obstructions that might interfere with autosamplers, or that limit access to the top of the instrument. The area must include sufficient space behind the GC to allow for cooling.

WARNING

Be careful when lifting the GC. Because it is heavy, two people should lift it. When moving the GC, be aware that the back is heavier than the front.

- 1 Remove the GC from its shipping box.
- 2 Place the GC on the bench top. Make sure gas and power supplies are accessible. Place related equipment near the GC.
- 3 If space is limited behind the GC, attach the optional oven exhaust deflector to the back of the GC as shown below. (Order Option 306 or part number G1530-80650.) The deflector hangs from the exhaust vents on four hooks.

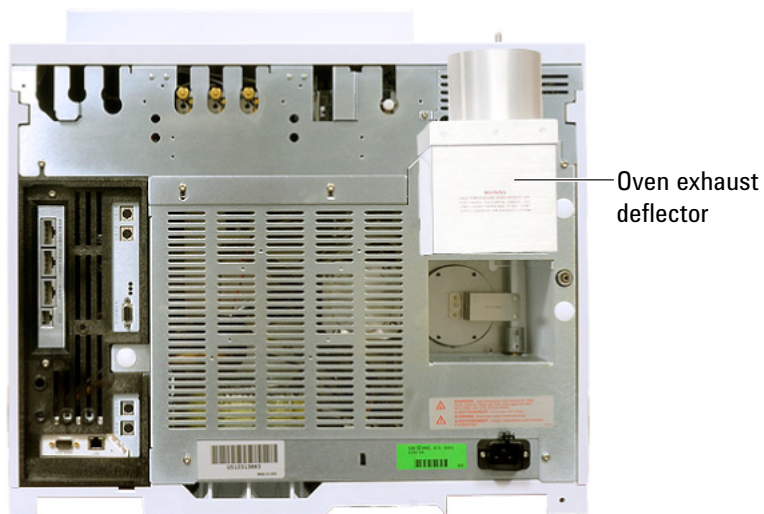


Figure 3 Correct position of the oven exhaust deflector

The oven exhaust deflector accepts a 10-cm (4 in.) diameter exhaust duct, and adds about 13 cm to the depth of the GC.

Step 2. Verify line voltage, voltage settings, and power cord.

- 1 Locate the power label near the power cord connector on the back of the GC. (See Figure 2.) Compare the instrument power settings with the laboratory line voltage. See “Power consumption” below.
- 2 Verify that the power cord is correct for the voltage and location. See “Power cords available” on page 15.

WARNING

Electrical shock hazard. To avoid injury, only a qualified person should measure line voltage.

- 3 Have a qualified person measure the actual power outlet voltage and verify it meets the tolerance requirements listed in Table 1 on page 15. See “Grounding” on page 19 and “Line voltage” on page 19.

The next sections detail the power specifications and requirements for reference.

Power consumption

The number and type of electrical outlets required for installation depends on the size and complexity of your system. A GC system with a computer, monitor, printer, and hub requires 5 outlets. **The outlet for the GC must have a dedicated ground.**

Each GC has a label next to the power cord connector that lists its line voltage requirements. See the examples below.



The GC power consumption and requirements depend on the type of oven that you ordered and the country the unit shipped to. Fast oven options 002 and 003 require more power than the standard oven.

Table 1 GC power requirements

Oven	Line voltage	Frequency	Current	Power	Power outlet current rating
Standard	Americas: 120 V AC (1) single phase, +10 to -10%	48-63 Hz	18.8 amps	2250 VA	20 A
Standard	220/230/240 V single/split phase, +10 to -10%	48-63 Hz	10.2 / 9.8 / 9.4 amps	2250 VA	10 A
Fast	Japan: 200 V split phase, +10 to -10%	48-63 Hz	14.8 amps	2950 VA	15 A
Fast	220/230/240 V (2)(3) single/split phase, +10 to -10%	48-63 Hz	13.4 / 12.8 / 12.3 amps	2950 VA	15 A

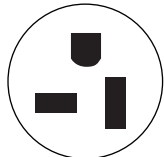

Notes

- 1 Some US labs have 4-wire service resulting in 208 V at the wall receptacle. It is important for a qualified person to measure the line voltage at the receptacle for the GC. Option 003, 208 V fast oven, uses a 220 V unit with operating range of 193 to 231 V.
- 2 Power line conditioners should not be used with the GC.

Power cords available

Table 2 lists the power cords available for the GC. If your power cord is incorrect, order the cord appropriate for the country.

Table 2 Power cords by country

Part number	Country	Description	Wall termination	Plug termination
8120-1992	US	Power Cord, C13 125V 13A NEMA 5-15 HG US	NEMA 5-20P	
8120-3997	Denmark, Greenland	Power Cord, DK/Greenland, C13, 10 amp	AFSNIT 107-2-01	

1 Installing the GC

Table 2 Power cords by country (continued)

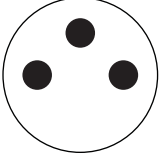
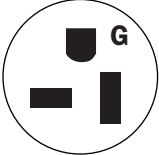
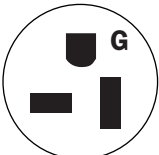
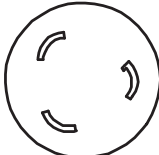

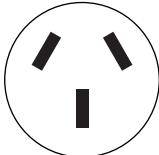

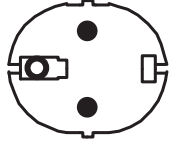

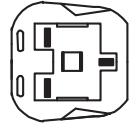
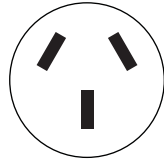
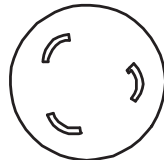
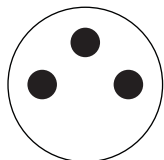
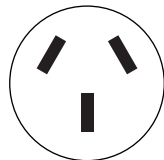
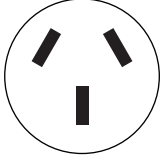
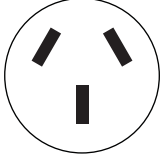
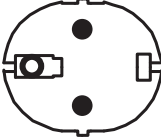
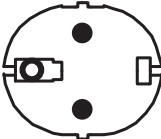


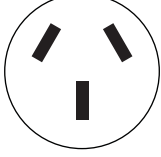
Part number	Country	Description	Wall termination	Plug termination
8120-5182	Israel	Power Cord, Israel, C13, 10 amp	Israeli SI32	
8120-6360	Taiwan, South America	Power Cord, Taiwan/S America, C19, 20A	NEMA 5-20P	
8120-6894	US	Power Cord, US 120V, C19, 20 amp	NEMA 5-20P	
8120-6903	Japan	Power Cord, Japan, C19, 20 amp	NEMA L6-20P	
8120-6978	Chile	Power Cord, Chile, C13, 10 amp	CEI 23-16	
8120-8619	Australia	Power Cord, Australia, 16 amp	AS 3112	
8120-8620	Great Britain, Hong Kong, Singapore, Malaysia	Power Cord, GB/HK/SG/MY, C19, 13 amp	BS1363	

Table 2 Power cords by country (continued)

Part number	Country	Description	Wall termination	Plug termination
8120-8621	Europe	Power Cord, Europe, 16 amp	CEE7/V11	
8120-8622	Switzerland, Denmark	Power Cord, Swiss/DK, C19, 16 amp	Swiss/Denmark 1302	
8120-8705	Great Britain, Hong Kong, Singapore, Malaysia	Power Cord, GB/HK/SG/MY, C13, 10 amp	BS89/13	
8121-0070	China	Power Cord PRC Fast	GB 1002	
8121-0075	US	Power Cord, US 240V, C19, 15 amp	NEMA L6-20P	
8121-0161	Israel	Power Cord, Israel, C19, 16 amp	Israeli SI32	
8121-0675	Argentina	Power Cord, Argentina, C19, 20 amp	AS 3112	

1 Installing the GC

Table 2 Power cords by country (continued)

Part number	Country	Description	Wall termination	Plug termination
8121-0710	India, South Africa	Power Cord, India/S.Africa, C19, 15 Amp	AS 3112	
8121-0723	China	Power Cord, China, C13, 10 amp	GB 1002	
8121-1222	Korea	Power Cord, Korea, C19, 16 amp	CEE7/V11	
8121-1226	Korea	Power Cord, Korea C13, 10 amp	CEE7/V11	
8121-1301	Thailand	Power Cord, Thai 220V, 15 A, 1.8M, C19		
8121-1787	Brazil	Power Cord, Brazil, C19, 16 A, 250V Max	IEC 60906-1	
8121-1809	Brazil	Power Cord, Brazil, C13, 10 A, 250V Max	IEC 60906-1	
8120-1369	Australia, New Zealand	Power Cord, Australia/NZ, C13, 10 amp	AS 3112	

Grounding

To protect users, the metal instrument panels and cabinet are grounded through the three-conductor power line cord in accordance with International Electrotechnical Commission (IEC) requirements.

The three-conductor power line cord, when plugged into a properly grounded receptacle, grounds the instrument and minimizes shock hazard. A properly grounded receptacle is one that is connected to a suitable earth ground. Proper receptacle grounding should be verified.

Make sure the GC is connected to a dedicated receptacle (outlet).

Line voltage

The GC operates from one of the AC voltage supplies listed in [Table 1](#), depending on the standard voltage of the country from which it was ordered.

GCs are designed to work with a specific voltage; make sure your GC voltage option is appropriate for your laboratory. The voltage requirements for your GC are printed near the power cord connector.

Although your GC should arrive ready for operation in your country, compare its voltage requirements with those listed in [Table 1](#). If the voltage option you ordered is not suitable for your installation, contact Agilent Technologies.

Line power cord terminations

The power cord termination is determined by the country where the GC is ordered.

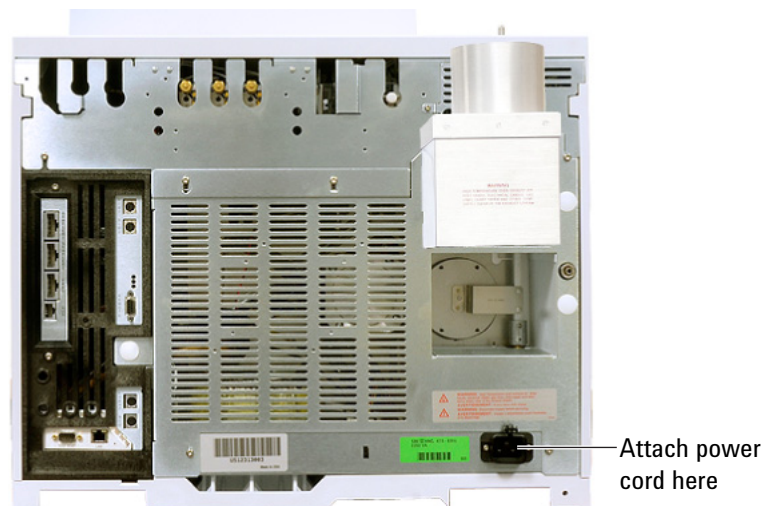
Step 3. Connect the power cord and turn on the GC

- 1 Verify that the power switch is in the Off position.

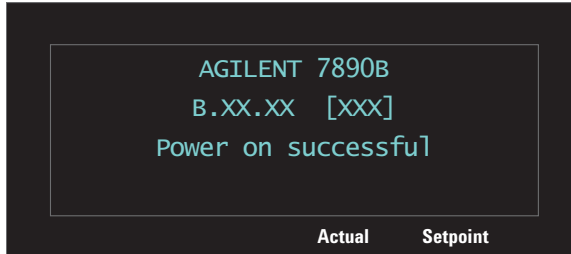


Figure 4 Power switch location

- 2 Plug the power cord into the back of the GC and the power outlet.



- 3 Turn on the GC. The self-test diagnostic tests run automatically. If the screen displays **Power on successful**, continue with the installation procedure.



Step 4. Connect gases and traps

Most of installation involves plumbing gas to tanks, filters, and flow modules. Swagelok fittings are used to make leak-tight connections. If you are not sure how to make a Swagelok connection, see [Appendix A](#) for instructions.

WARNING

Hydrogen is a flammable gas. If hydrogen or any other flammable gas is used, periodic leak tests should be performed. Be sure that the hydrogen supply is off until all connections are made, and insure that the inlet fittings are either connected to a column or capped at all times when hydrogen gas is present in the instrument.

Substituting parts or performing any unauthorized modification to the instrument may result in a safety hazard.

The insulation around the inlets, detectors, valve box, and the insulation cups is made of refractory ceramic fibers (RCF). To avoid inhaling RCF particles, we recommend these safety procedures: ventilate your work area; wear long sleeves, gloves, safety glasses, and a disposable dust/mist respirator; dispose of insulation in a sealed plastic bag; wash your hands with mild soap and cold water after handling RCFs.

Install the gas regulators

- 1 Select the appropriate CGA regulator for each gas type. (In other countries, refer to local standards. See the [Agilent GC, GC/MS, and ALS Site Preparation Guide](#) for requirements.)

Table 3 Gas regulators, 1/8-inch, U.S. only *

Description	Part number
CGA 346, 125 psig max (8.6 bar), Air	5183-4641
CGA 350, 125 psig max (8.6 bar), H ₂ , Ar/Me	5183-4642
CGA 540, 125 psig max (8.6 bar), O ₂	5183-4643
CGA 580, 125 psig max (8.6 bar), He, Ar, N ₂	5183-4644
CGA 590, 125 psig max (8.6 bar), Air	5183-4645

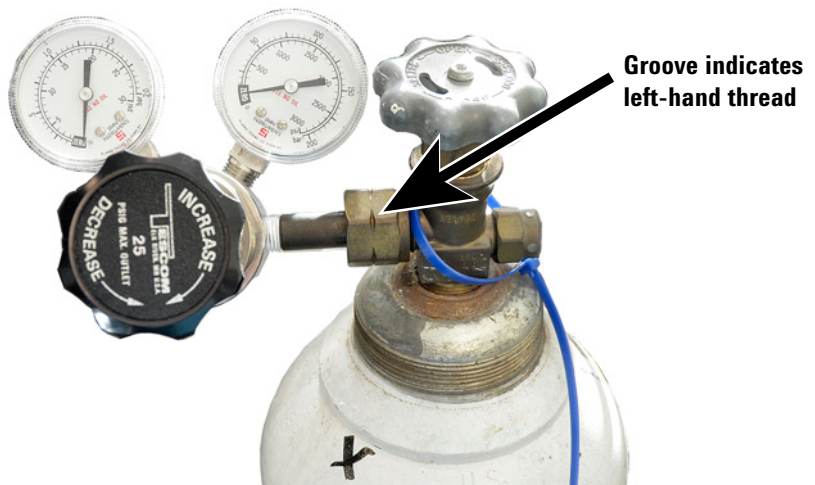
* For 1/4-inch tubing, purchase a 1/4-inch to 1/8-inch adapter, U.S. only.

- 2 Confirm that the outlet fitting of the regulator is 1/8-inch Swagelok. If not, install the appropriate adapter fitting. Wrap

the fitting threads using PTFE tape. Wrap the tape in a clockwise direction so that the adapter threads do not unwrap the tape. Be careful to keep the tape away from the end of the fitting. Two to three tightly wound wraps are sufficient. **Never use a liquid thread sealant.** Liquid thread sealants introduce contamination into the GC plumbing system. Tighten the Swagelok adapter fitting securely to the NPT pipe thread fitting.

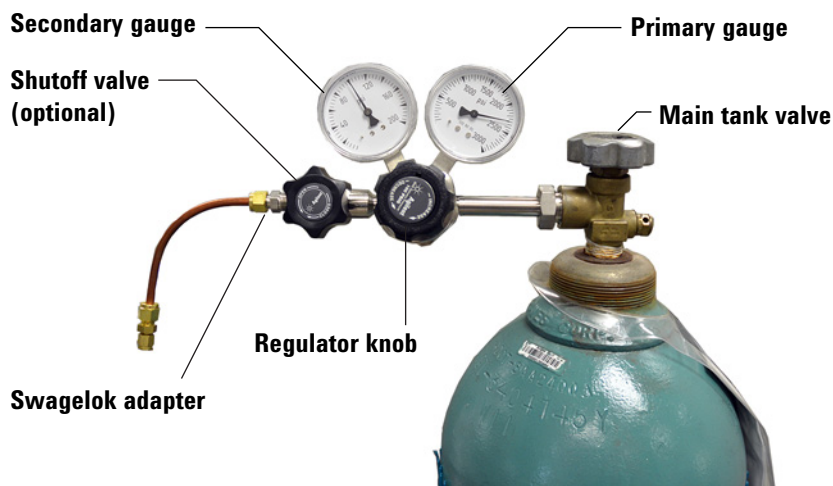


- 3 Install the regulator onto the compressed gas cylinder main fitting.
 - Check the thread type. Some regulators use left-hand thread fittings. For left-handed threads, the nut will have a groove in it.



- 4 Purge the air from the regulator by repeating the following procedure 5 times:
 - a Fully close the regulator knob, then open the main tank valve.
 - b Turn the regulator knob fully counter-clockwise to open the tank main valve, pressurizing the primary side of the regulator.
 - c Turn OFF the tank main valve.
 - d Slowly turn the regulator knob clockwise to release ("bleed off") the gas pressure.
 - e Close the regulator knob.

The image below illustrates a typical pressure regulator installation. In the example shown below, which uses an optional shutoff valve, open the shutoff valve and leave open during purging.



Connect the tubing to the gas source

NOTE

If you need more than 4.5 m (15 feet) supply tubing for a gas source, use 1/4-inch tubing with appropriate hardware. See the [Agilent GC, GC/MS, and ALS Site Preparation Guide](#) for part numbers.

- 1 Turn off all gases at their sources. Measure the length of tubing needed to connect the gas supply outlet to the inlet

fitting on the GC. Take into account any traps or tees you will need.

- 2 Cut the tubing to length with a tubing cutter (Figure 5).

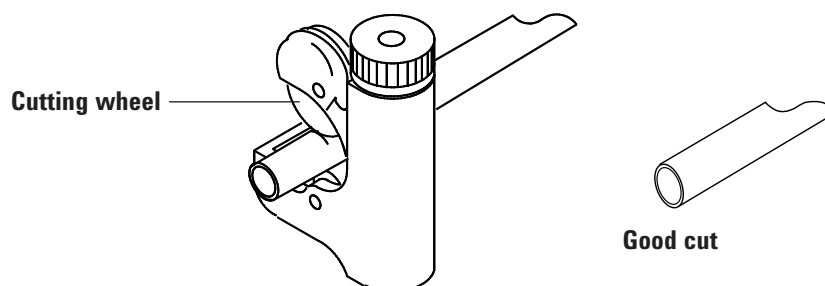


Figure 5 Typical tubing cutter

- 3 Connect the tubing to the gas source with a Swagelok fitting. See [Appendix A](#), “Making Swagelok Connections.”

Install traps

- 1 Determine where you will install the traps in your supply tubing line. [Figure 6](#) shows the recommended trap order for the carrier gas and the recommended locations for On/Off valves. See also the [Site Preparation Guide](#).

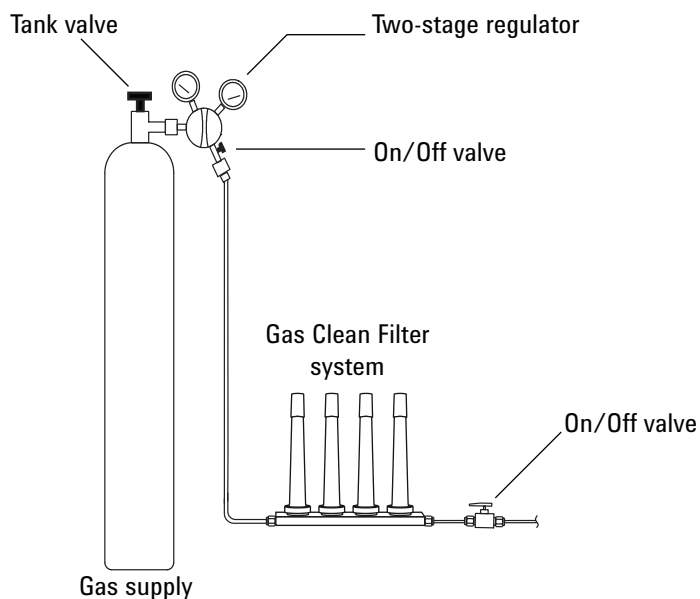


Figure 6 Plumbing the gas supplies

- 2 Cut the tubing to length with a tubing cutter.

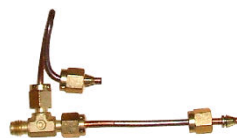
- 3 Connect the traps and tubing. On/Off valves are not essential, but are very useful when a tank or trap must be changed. (If purchasing Agilent compliance services, install an on/off valve for each inlet gas supply.)

Supplied fittings

Every GC ships with pre-assembled Tee fittings appropriate for the number and types of inlets and detectors. (Customers who ordered the pre-plumbed option will receive additional supplies and fitting assemblies.)



G3430-20029 Inlet Tee assembly, sized to accommodate two shutoff valves (not supplied)



G3430-60009 Detector Tee assembly

Plumb to EPC flow modules

Inlet and detector EPC flow modules are mounted very close together across the back of the GC. See Figure 7.

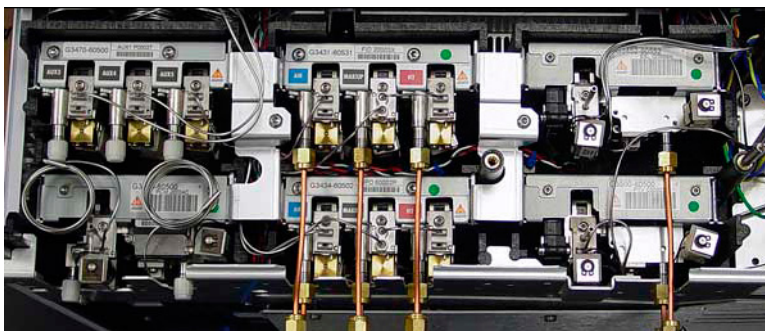


Figure 7 Plumbing flow modules

WARNING

Be sure to vent uncombusted hydrogen to a fume hood or other safe location.

Purge the supply lines for a few minutes before connecting them to the GC flow modules.

Inlet flow module

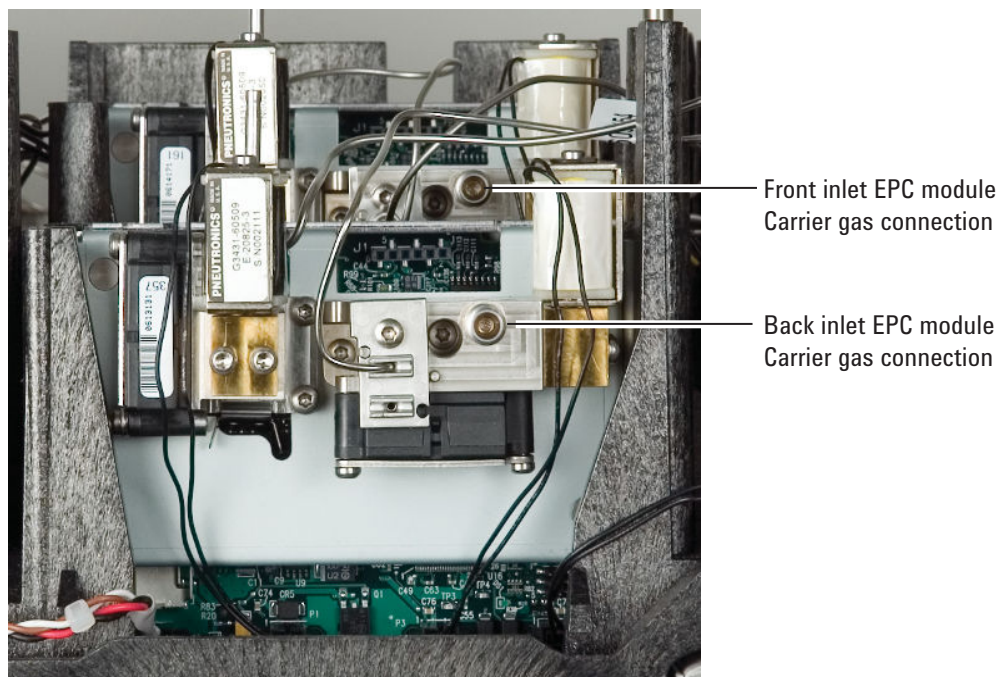


Figure 8 Inlet flow module

1 Installing the GC

When two inlets use the same carrier gas, we recommend using a Tee fitting that includes shutoff valves for performing leak tests. Add shutoff valves to the supplied pre-plumbed Tees or assemble Tees as shown below.

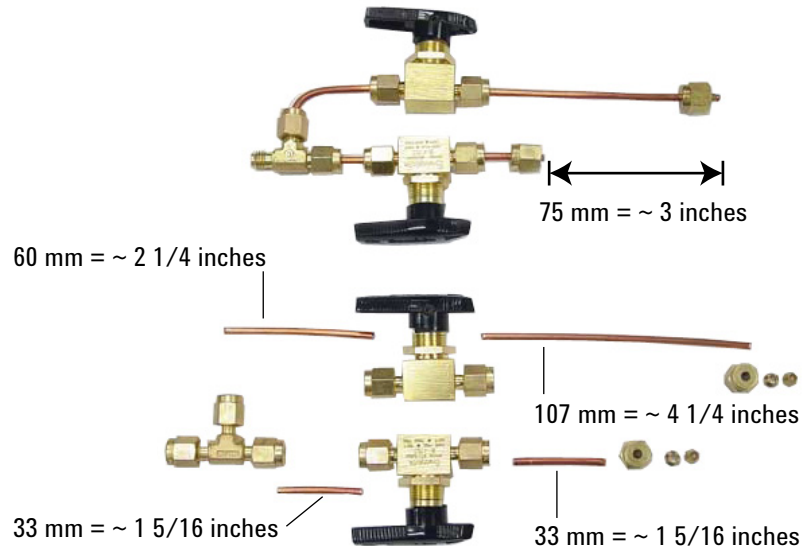


Figure 9 Tee for inlet flow module

Detector flow module



Figure 10 Detector flow module

When two detectors use the same gases, we recommend using a Tee fitting. Shutoff valves are not required. Use the supplied Tees or assemble Tees as shown below.

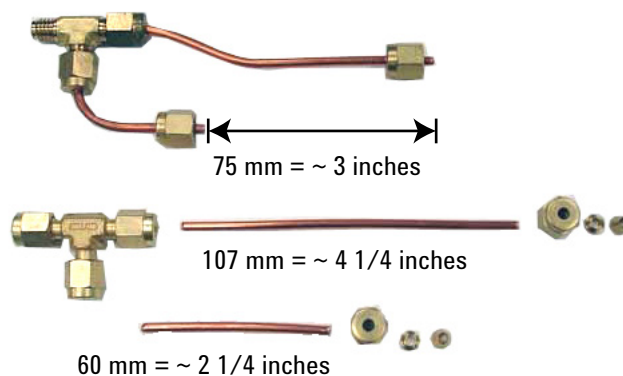


Figure 11 Tee for detector flow module

TCD connections The carrier gas and reference gas must come from the same source. Because of the close spacing of the EPC modules, the simplest way to do this is to attach lengths of tubing to each input to bring the ends outside the back panel, then join them with a Tee.

Side panel detector connections If the GC is equipped with a side-mounted TCD or μ ECD, attach the carrier gas to the single gas connection at the back of the side mount enclosure. (For TCD, an internal Tee feeds the reference gas or input.)

Install Aux EPC module frits for your application

Skip this section if an Aux EPC module is not installed.

The AUX EPC module ships with brown (FID air) restrictors in all channels. For certain applications, you will have to replace this restrictor (frit) so the EPC module can provide flows in the correct ranges. See [Table 4](#). Also refer to the other instrument's or application's documentation.

Table 4 G3470-60502 Aux EPC restrictor kit

Kit contains	Part number	Marking	Flow	Resistance	Often used with
O-rings, 6/pk	5181-3344				
None	G3430-80061	1 ring Brown	400 ± 30 SCCM air @ 40 psig	Low	FID air, purged splitters, Deans switch
3	G3430-80062	2 rings Red	30 ± 1.5 SCCM H2 @ 15 psig	Medium	FID hydrogen
3	G3430-80063	3 rings Blue	3.33 ± 0.3 SCCM H2 @ 15 psig	High	NPD hydrogen
3	G3430-20011	None		Zero (none)	Purged splitter, Deans switch when using backflush

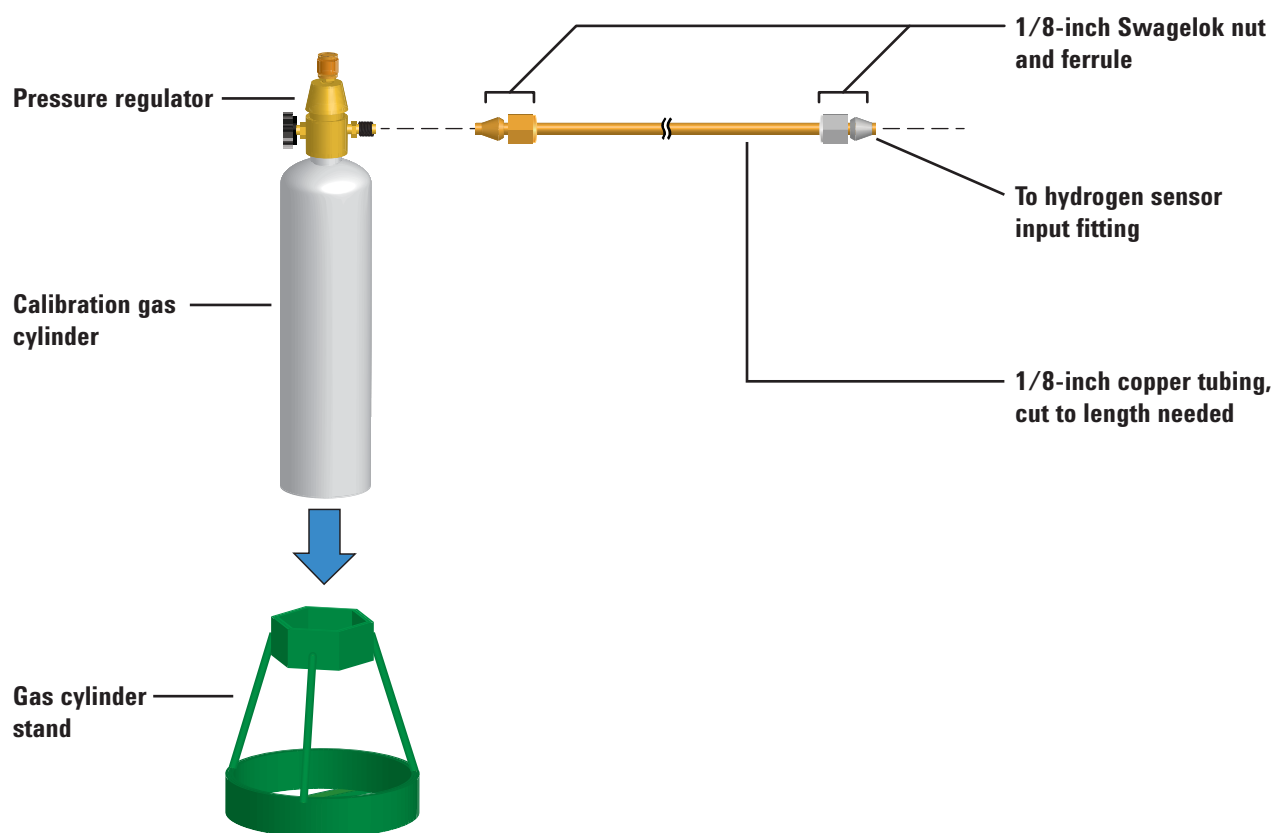
Notes for this table

- Frit G3430-80061 ships in each AUX channel.
- Restrictor kit G3470-60502 is included in the AUX module ship kit.
- Always use new O-rings (part number 5181-3344, O-rings, 6/pk).
- Install tubing and connectors as needed for each additional gas supply required.
- Do **not** install an external flow restrictor.
- For other restrictor recommendations, see the [Advanced Operation](#) manual.

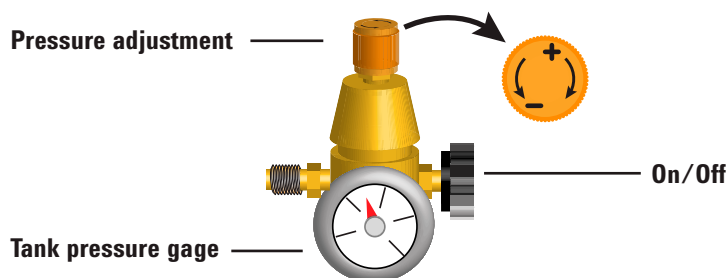
Install hydrogen sensor calibration gas

If available, install the hydrogen sensor calibration gas. The hydrogen sensor ship kit includes a pressure regulator that installs directly onto the calibration gas cylinder. Agilent also provides sufficient copper tubing and hardware to connect the pressure regulator to the hydrogen sensor assembly calibration gas input fitting.

- 1 Set the gas cylinder stand upright on the lab bench near the GC. (Do not place it behind the oven exhaust vent!)



- 2 Turn the pressure regulator completely off and set the output pressure as low as possible (full CCW).



1 Installing the GC

- 3 Install the pressure regulator onto the calibration gas cylinder (it screws on).
- 4 Connect the calibration gas cylinder output tubing to the hydrogen sensor module.
 - Use the tubing, nuts, and ferrules provided in the hydrogen sensor kit.
 - See the figure under [step 1](#).
- 5 Install the calibration gas cylinder into the stand and secure using the screw.
- 6 Turn on the supply pressure at the pressure regulator. (You will adjust it later.)
- 7 Check for leaks in the fittings using a leak detection fluid. Correct any leaks.

Step 5. Leak test all connections and set source pressures

Liquid leak detectors, such as soapy water, are not recommended, especially in areas where cleanliness is very important. If there is a leak, these liquids can contaminate the plumbing and affect your analyses. If you do use leak detection fluid, immediately rinse the fitting to remove the soapy film.

When checking for leaks of hydrogen or helium, Agilent recommends the G3388B leak detector, or similar.

WARNING

To avoid a potential shock hazard when using liquid detection fluid, turn the GC off and disconnect the main power cord. Be careful not to spill leak solution on electrical leads.

Perform a pressure drop test.

- 1 Turn off the GC.
- 2 Set the regulator pressure to 415 kPa (60 psi).
- 3 Fully turn the regulator pressure adjustment knob counterclockwise to shut the valve.

1 Installing the GC

- 4 Wait 10 min. If there is a pressure loss greater than 7 kPa (1 psi), there is a leak in the external connections. Use the leak detector to check each fitting for leaks. See Figure 12.

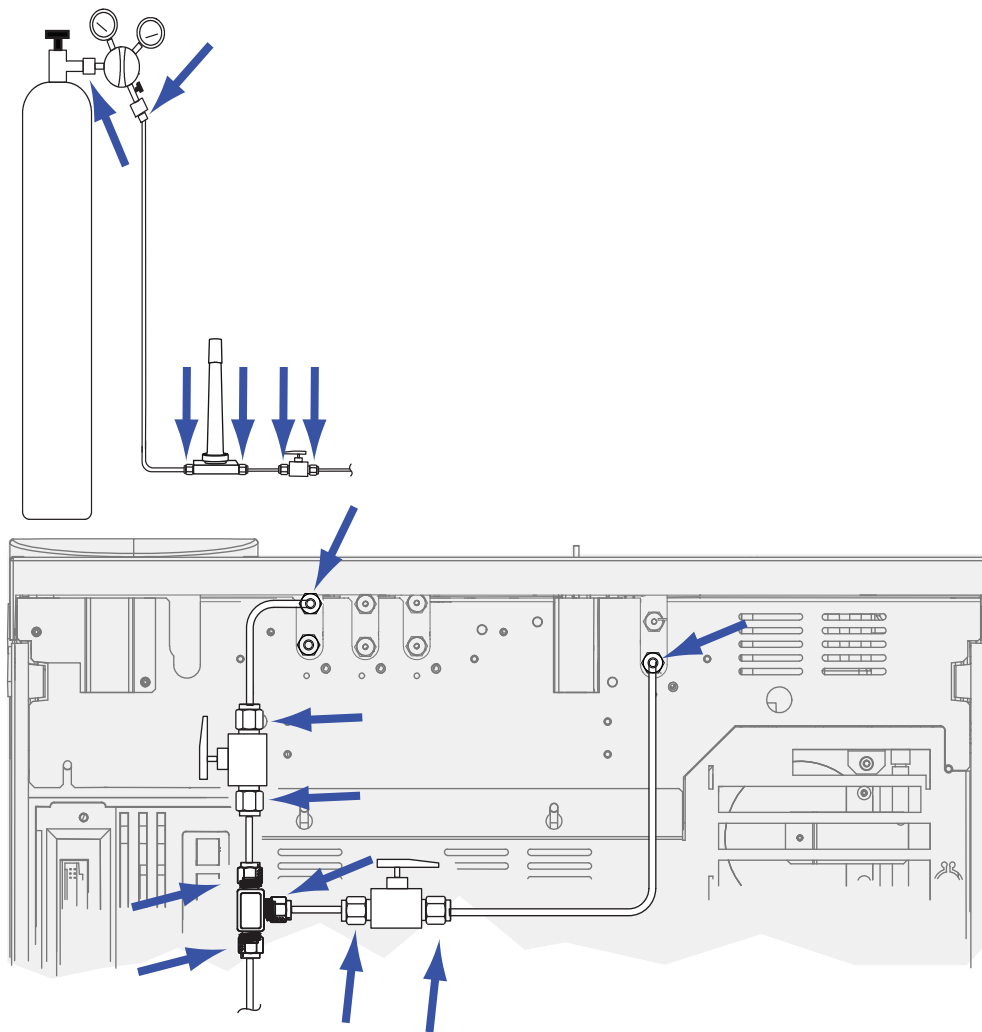


Figure 12 Locations to check for leaks

Correct leaks by tightening the connections. Retest the connections; continue tightening until all connections are leak-free.

Set source gas pressures

The pressure set at a tank regulator depends on these factors:

- The inlet pressure needed to achieve the highest column flow rate required by your method.

The pressure/flow relationship depends on the column or device involved. The best way to address this is to begin at a moderate pressure level and adjust upward as needed.

- A pressure difference of about 170 kPa (25 psi) across flow controlling devices enables them to work properly.
- The pressure limit of the weakest part of the supply system.

Swagelok fittings and copper tubing are more than adequate for the highest pressures used in gas chromatography.

We recommend a maximum continuous operating pressure of 1170 kPa (170 psi) to avoid excessive wear and leaks.

Traps are often the weakest part of the system. They should be labeled, either on the trap itself or in accompanying literature, with a maximum operating pressure. Source pressure must not exceed the lowest maximum operating pressure in the supply system.

Table 5 suggests starting values of source pressure.

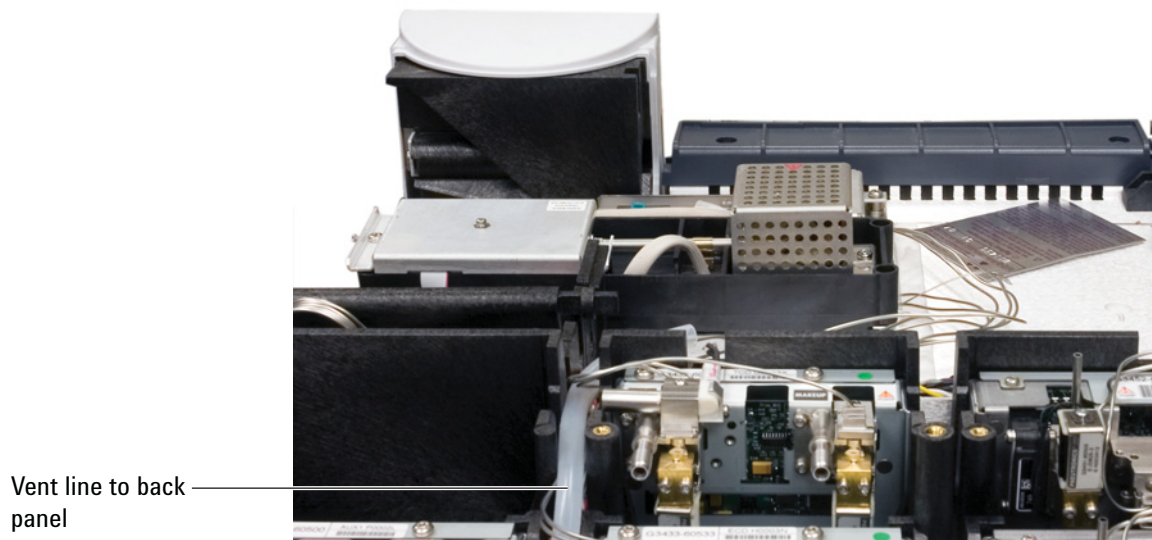
Table 5 Suggested starting pressures

Gas	Use	Source pressure
Carrier	Packed column	410 kPa (60 psi)
	Capillary columns	550 kPa (80 psi)
Air for FID, FPD	Detectors	550 kPa (80 psi)
Hydrogen	Detectors	410 kPa (60 psi)
Makeup gas	Detectors	410 kPa (60 psi)
TCD Reference	TCD	410 kPa (60 psi)
Air for valve actuators	Valves	345 kPa (50 psi)

Step 6. Vent μ ECD or uncombusted hydrogen to a fume hood

If using a μ ECD, or if using hydrogen carrier gas that will be uncombusted, you must either safely vent the exhaust or operate the GC inside a fume hood. For example, if using hydrogen carrier gas the GC would vent uncombusted hydrogen from a thermal conductivity detector (TCD) and from the inlet split vent and septum purge vent.

The μ ECD exhaust vents through a coiled tube. Connect tubing from the tube fitting at the end of this tubing to an exhaust hood via a hole in the back panel.



For a TCD, you must supply vent tubing and fittings to connect to the detector exhaust tube on the top of the detector. Route the tubing out the back of the GC, following the same path as for the μ ECD vent tubing.

The other detectors (FID and FPD) combust any hydrogen carrier gas.

Step 7. Connect cryogenic cooling (if present)

Cryogenic cooling allows you to cool the oven or inlet, including cooling to setpoints below ambient temperature. A solenoid valve controls the flow of coolant to the inlet or oven. The oven can use either liquid carbon dioxide (CO₂) or liquid nitrogen (N₂) as a coolant. All inlets except the multimode inlet must use the same coolant type as the oven. The multimode inlet can use a different coolant than configured for the oven, and can also use compressed air as a coolant.

CO₂ and N₂ coolants require different hardware on the GC. (You can use air cooling on a multimode inlet, with either the CO₂ or N₂ solenoid valves and hardware.)

Flared or AN tubing fittings are commonly used to connect the liquid supply tubing to the cryo coolant tank. Check with the supplier of the coolant before plumbing to be sure you have the correct fittings.

Connecting liquid carbon dioxide

WARNING

Do not use copper or thin-wall stainless steel tubing! Either presents an explosion hazard.

CAUTION

Do not use padded tanks for CO₂ supplies. The cryogenic valve is not designed to handle the higher pressures padded tanks generate.

The tank must be equipped with an eductor tube (dip tube) that reaches to the bottom of the tank, so that liquid (rather than gaseous) CO₂ is drawn.

Materials needed:

- 1/8-inch heavy-wall, stainless steel tubing
- 1 Locate the inlet for liquid CO₂ on the left side of the GC. Prepare enough tubing to reach from the supply tank to this fitting. See [Figure 13](#).

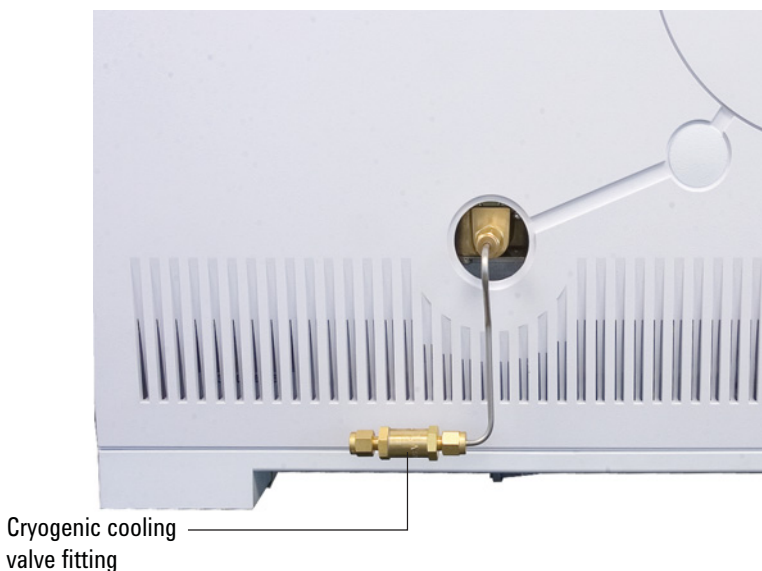


Figure 13 Location of cryogenic cooling valve

- 2 Connect the supply tubing to the liquid CO₂ tank outlet with the fitting recommended by the supplier.

- 3 Use a Swagelok fitting to connect the supply tubing to the cryogenic valve inlet.

Connecting liquid nitrogen

Materials needed:

- 1/4-inch insulated copper tubing
- 1 Position the nitrogen tank as close to the GC as possible to insure that liquid and not gas is delivered to the inlet.
 - 2 Locate the inlet for coolant on the left-hand side of the GC. Prepare enough tubing to reach from the supply tank to this outlet. See Figure 14.



Figure 14 N₂ cryogenic cooling valve connections

- 3 Connect the supply tubing to the liquid N₂ tank outlet with the fitting recommended by the supplier.
- 4 Use a Swagelok fitting to connect the supply tubing to the cryogenic valve inlet.

Connecting air to the multimode inlet

The multimode inlet can also use compressed air cooling with the liquid N₂ inlet cooling option. Requirements for compressed air cooling:

- The compressed air should be free of particulate material, oil, and other contaminants. These contaminants could clog the inlet's cryo valve and expansion orifice or impact the proper operation of the GC.
- The required air supply pressure depends on the installed solenoid valve type. For a multimode inlet with N₂ cooling, set the air supply pressure to 138 to 276 kPa (20 and 40 psig).

While air supplied from tanks can meet these criteria, the consumption rate of air can be 80 L/min, varying based on supply pressure.

NOTE

A noise reduction kit, G3510-67001, is available for users of compressed air cooling with a multimode inlet.

Materials needed:

Installation of a compressed air line to the inlet cryo coolant valve requires the hardware (and appropriate fittings) noted below:

- Use 1/4-inch copper or stainless steel tubing for supply tubing to the N₂ valve
- 1 Locate the input fitting for inlet coolant on the left-hand side of the GC. Prepare enough tubing to reach from the supply to this outlet.
 - 2 Connect the supply tubing to the air supply outlet with the fitting recommended by the supplier.
 - 3 Use a Swagelok fitting to connect the supply tubing to the cryogenic valve input fitting.

Step 8. Connect valve actuator air (if present)

Valves are driven by air actuators. Valves should have a dedicated air source; they cannot share detector air supplies.

CAUTION

Do not share air between a detector and valves.

Valves can use nitrogen as an alternate supply. In this case, the nitrogen does not have to be chromatographic grade but must be free from contaminants.

Valve actuator air is supplied through 1/4-inch plastic tubing. If your GC was ordered with valves, the plastic tubing will already be attached to the actuators and will extend from the back of the GC. Additional valves are shipped with a 1/4- to 1/8-inch reducing union to be used in plumbing.

CAUTION

Route the tubing away from the oven exhaust. The hot air will melt the plastic tubing.

Turn off the air supply at the source. If needed, shorten the supplied plastic tubing using a sharp knife. Connect the tubing to the air source using a 1/4-inch Swagelok nut and ferrules. See Figure 15.

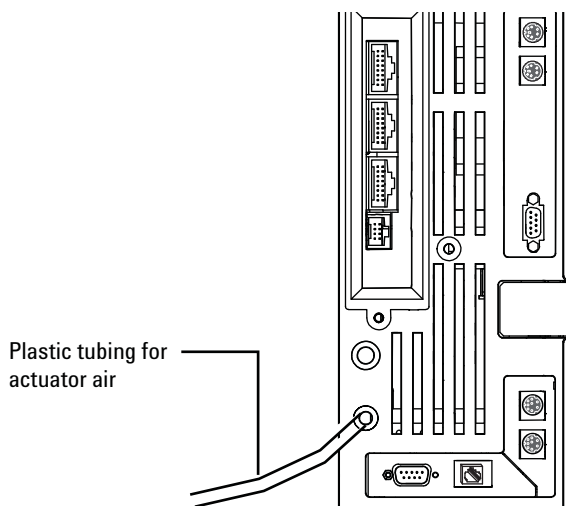


Figure 15 Valve actuator air tubing

Step 9. Install inlet checkout parts

If using a split/splitless or multimode inlet, install the liner and O-ring needed for checkout. See [To Prepare for Chromatographic Checkout](#). Also see the procedures listed in *Maintaining Your GC*.

[Split/splitless inlet](#)

[Multimode inlet](#)

If installing a GC/MS system, refer to the GC/MS installation manuals for the correct inlet hardware to install, as needed.

Step 10. Install ALS, if ordered

If installing an ALS, install it now. Refer to its instructions.

Prepare the sampler for checkout. See the checkout procedures and information in the [Operation Manual](#).

- 1 Prepare a 2-mL screw-top sample vial.
- 2 Prepare 4-mL waste vials and place them into the turret.
- 3 Prepare fresh solvent solutions as needed for the checkout sample for your detector type. Place the solvent vials into the injector turret. For details on the solvent needed, see the *Operation Manual*:
 - FID checkout
 - FPD⁺ checkout
 - FPD⁺ checkout (Japan)
 - NPD checkout
 - TCD checkout
 - μ ECD checkout

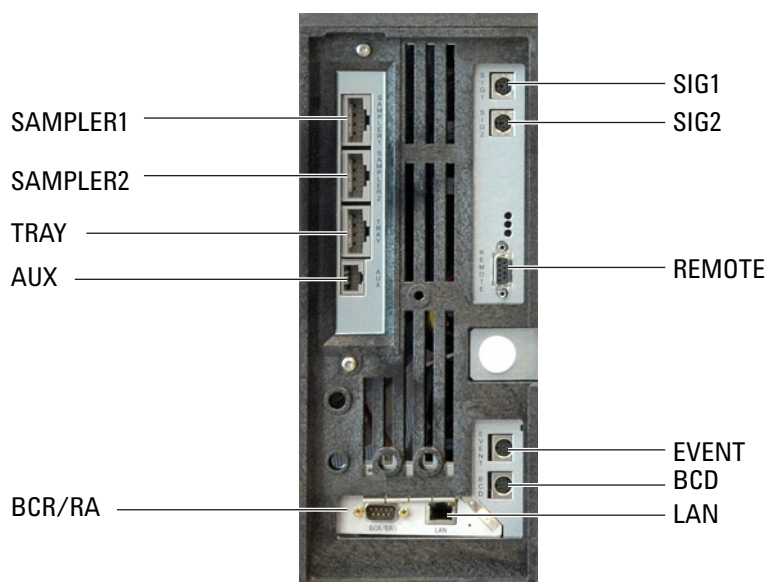
Step 11. Connect the external cables

Most installations involve plugging a cable from the LAN into the GC's LAN cable port. Additional cables may be installed for control of the GC's automatic liquid sampler (ALS), connecting signal output to integrators, synchronizing the start and end of a run between various instruments, sensing conditions external to the GC, and controlling devices external to the GC.

If using Event or BCD cables, label the cables as needed to identify their intended use and appropriate connector on the GC. See [Labeling BCD and EVENT cables](#).

Back panel connectors

The figure below shows the connectors on the back panel of the GC.



See also “[Cable Diagrams](#)” on page 86.

Sampler connectors

If using an ALS, connect it to the GC using the following connectors:

SAMPLER 1 Optional. An injector, usually the front injector. (For 7693A/7650, the GC automatically senses the injector location. For a 7683 injector, typically configure this injector as **INJ1**.)

SAMPLER 2 Optional. A second injector, usually the back injector. (For 7693A/7650, the GC automatically senses the injector location. For a 7683 injector, typically configure this injector as **INJ2**.)

TRAY Optional. The 150-position sample tray (includes optional barcode reader/heater/mixer control, if purchased).

The AUX connector

Do not use. This connector is reserved for future development.

The SIG (analog output) connectors

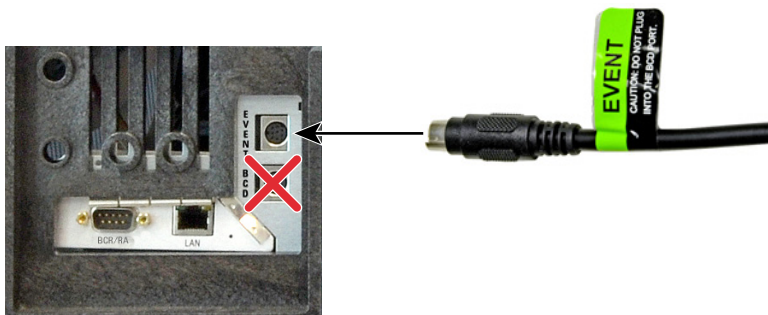
Optional. Use **SIG1** and **SIG2** for analog output signals.

REMOTE connector

Provides a port to remotely start and stop other instruments using the APG protocol. A maximum of 10 instruments can be synchronized using this connector. See [“Using the Remote Start/Stop Cable”](#) on page 78 for more detail.

EVENT connector

This connector provides two passive contact closures and two 24-volt outputs for controlling external devices. The outputs are controlled by valve drivers 5 through 8.

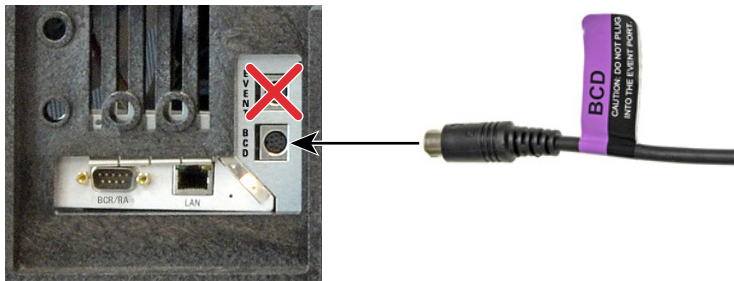


BCD input connector

This connector provides two control relays and a BCD input for a stream selection valve or a BCD generating device.

CAUTION

This connector is similar to the **EVENT** connector. Plugging a non-BCD cable into the **BCD** connector can damage the GC.



BCR/RA connector

This connector is reserved for the optional G3494B RS-232 Barcode Reader. Refer to the GC *Operation Manual*.

LAN connector

Standard Local Area Network (LAN) connector, for communication with data systems and other devices via TCP/IP.

Connecting cables

Use the supplied LAN cable to connect the GC to a LAN switch or hub as shown below (see Figure 16). Other LAN configurations are possible. However Agilent typically supports only simple LAN setups. Refer to your Agilent data system documentation for details about its supported LAN configurations.

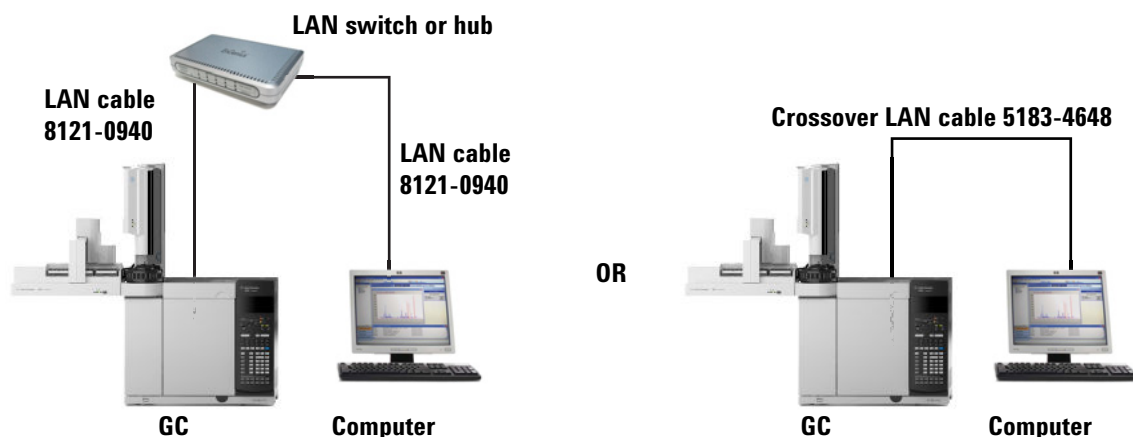


Figure 16 Simple supported LAN configurations: LAN switch or hub (left) and direct connection (right)

Table 6 Typical IP addresses for an isolated LAN

	GC	Computer
IP address	10.1.1.101	10.1.1.100
Subnet mask	255.255.255.0	255.255.255.0

A single LAN communications cable is supplied with the GC. The switch (or hub) and other cables must be ordered separately, if needed. See [Table 6](#) and [Table 7](#) for cabling requirements for other configurations.

Table 7 Cabling requirements

7890 Series GC connected to:	Required Cable(s)	Part number
Samplers		
7693A Automatic Liquid Sampler	Injector cable or tray cable	G4514-60610
7650 Automatic Liquid Sampler	Injector cable	G4514-60610

Table 7 Cabling requirements (continued)

7890 Series GC connected to:	Required Cable(s)	Part number
7683 Automatic Liquid Sampler	Injector cable is integral Tray cable	G2614-60610
7697A Headspace Sampler	Remote, 9-pin male/6-pin connector	G1530-60930
G1289B/G1290B Headspace Sampler	Remote, 9-pin male/6-pin connector	G1530-60930
CTC automatic sampler	Cable, 4 conductor, remote start	G6500-82013
Mass Spectrometers and MS systems		
Mass Selective Detector	Remote, 2-m, 9-pin male/9-pin male	G1530-60930
Ion trap 220 MS	Sync cable	G3930-60027
Ion trap 240 MS	Sync cable	G3931-60025
GC / Agilent external sampler / MS or MSD system (for example, GC/HS/MSD or GC/Thermal Desorber/MSD)	Y-Cable, remote start/stop	G1530-61200
GC / TMS-9800/ MS or MSD system	Y-Cable, remote start/stop Interface cable for Agilent 6890/7890 to P&T	G1530-61200 14-6689-086
Integrators		
3395B/3396C Integrator	Remote, 9 pin/15 pin Analog, 2 m, 6 pin	03396-61010 G1530-60570
Non-Agilent Integrator	General purpose analog signal cable 2 m, 6 pin	G1530-60560
Non-Agilent data system	General use remote, 9-pin male/spade lugs (various lengths)	35900-60670 (2 m), 35900-60920 (5 m), 35900-60930 (0.5 m)
Other devices		
Non-Agilent instrument, unspecified	External event, 8 pin/spade lugs (No label. See “Labeling BCD and EVENT cables”.)	G1530-60590
Valco pulser module (used with PDHID)	Valve pulser module power supply cable (includes green EVENT label)	G1580-60730
Stream selection valves Gas sampling valves (external)	See documentation accompanying the valve External valve cable (includes green EVENT label)	 G1580-60710
LAN		
LAN	Cable, networking CAT 5, 25 feet Cable, LAN, crossover	8121-0940 5183-4648

Table 8 Cabling for other instruments in a 7890 Series GC system

Instrument 1	Instrument 2	Type of cable	Part number
Mass Selective Detector	Purge & trap, thermal desorber, or headspace sampler	Splitter ("Y") cable for remote start/stop, 1 male and 2 female connectors	G1530-61200
		Splitter ("H") cable for APG remote, 2 male and 2 female connectors	35900-60800

Labeling BCD and EVENT cables

The **BCD** and **EVENT** connectors look similar. However, plugging an Event cable into the BCD connector can damage the GC logic board. To prevent accidental damage, the following BCD and Event cables come with labels that identify their intended use:

- G1580-60710, External valve cable
- G1580-60730, Pulsar Module Power Supply Cable
- G1580-61100, BCD Cable Assembly

For other cables, apply an Event or BCD label to the cable:

- G1580-87100, Caution label, BCD cable, purple
- G1580-87200, Caution label, Events cable, green



Configuring the GC IP address

For network (LAN) operation, the GC needs an IP address. It can be entered directly from the keyboard (recommended if using an Agilent data system) or obtained from a DHCP server (not recommended). In either case, see your LAN administrator.

To set the LAN address at the keyboard (recommended)

- 1 Turn on the GC.
- 2 Press **[Options]**. Scroll to **Communications** and press **[Enter]**.
- 3 Scroll to **Enable DHCP** and, if necessary, press **[Off/No]** to turn it off. When prompted, turn the GC off and then on again.
- 4 Press **[Options]**. Scroll to **Communications** and press **[Enter]**.
- 5 Scroll to **IP**. Enter the numbers of the GC IP address, separated by dots, and press **[Enter]**. A message tells you to power cycle the instrument. Do not power cycle yet. Press **[Clear]**.
- 6 Scroll to **GW**. Enter the Gateway number and press **[Enter]**. A message tells you to power cycle the instrument. Do not power cycle yet. Press **[Clear]**.
- 7 Scroll to **SM** and press **[Mode/Type]**. Scroll to the appropriate subnet mask from the list given and press **[Enter]**. A message tells you to power cycle the instrument. Do not power cycle yet. Press **[Clear]**.
- 8 Scroll to **Reboot GC** and press **[Enter]** to power cycle the instrument and apply the LAN setpoints.

Go to **[Options]> Communications**. If the GC IP address is 0.0.0.0, repeat [step 3](#).

To use a DHCP server (not recommended)

A DHCP IP address is often temporary. If it is assigned to another network device, the GC control software will be unable to connect to the GC.

- 1 Turn on the GC.
- 2 Press **[Options]**. Scroll to **Communications** and press **[Enter]**.
- 3 Scroll to **Enable DHCP** and press **[On/Yes]**. When prompted, turn the GC off and then on again.

GC / MS / Agilent data system / ALS

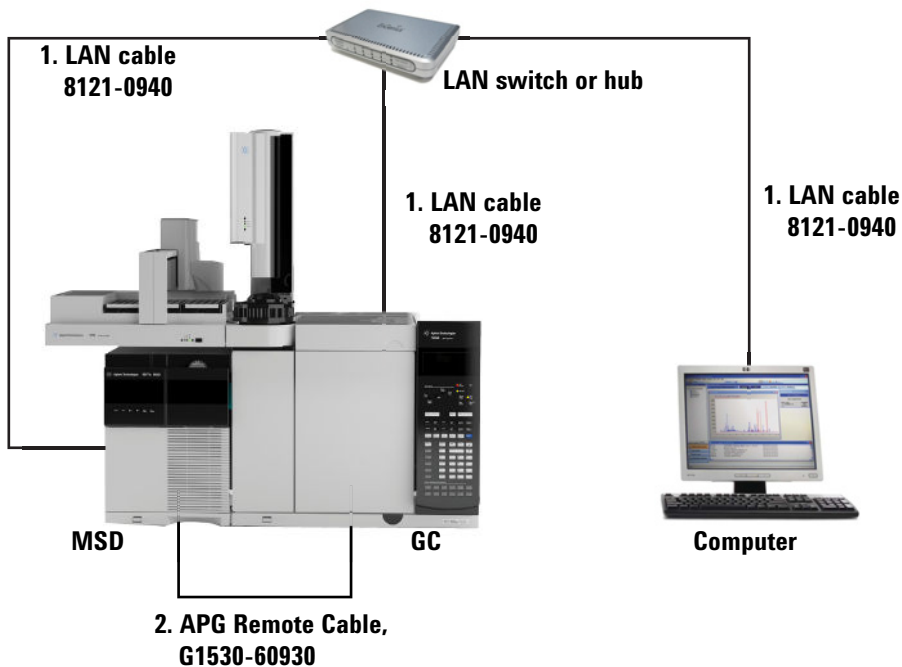


Table 9 Cables for a typical GC/MSD or GC/MS system

Number	Part number and description
1	G1530-60930, 2-m APG remote cable, 9-pin male/9-pin male
2	8121-0940, Cable, LAN, 25 foot

Additional cabling configurations

For additional cabling configurations, see [Appendix B](#), “Cabling Diagrams and Remote Start/Stop.”

Step 12. Finish configuring communications

If installing the GC as part of a system that includes other Agilent instruments capable of enhanced communications, configure the instruments as a system now. Agilent instruments capable of enhanced communications include the 5977 MSD, the 7000C Triple Quadrupole MS, and the 7697 Headspace Sampler with firmware A.01.06 or higher. Benefits of enhanced communications can include:

- Synchronized instrument clocks and resource conservation schedules
- Parameter sharing
- Consolidated Early Maintenance Feedback (EMF) tracking
- Integrated reactions to events, such as venting or shutdowns

Even if using an MS that does not support enhanced communications (for example, a 5975C MSD or 7000B MS), follow the instructions below to enable other features, such as the GC's MS Vent and MS shutdown methods, Parts Finder data, and so on.

Configuring GC-MS communications (5977A, 7000C, 7010)

After configuring the GC IP address, next configure the MS IP address (if not already done).

Once the instruments have IP addresses and are connected to the LAN, complete the GC/MS configuration and enable enhanced communications, Parts Finder data, and MS-friendly features such as the MS Vent method as follows:

- 1 Configure the MS transfer line.
 - a Press [**Aux Temp #**] and check if the MSD transfer line has been configured yet. When configured, the MS transfer

line thermal zone will be labeled. If configured, skip to [step 2](#). If unconfigured, continue with the steps below.

- b** Press [**Options**], select **Keyboard & Display** and press [**Enter**].
 - c** Scroll down to **Hard Configuration Lock** and press [**Off/No**].
 - d** Press [**Config**][**Aux Temp #**]. Scroll to the aux thermal zone for the MS transfer line and press [**Enter**].
 - e** With the cursor on the **Install Heater** line, press [**Enter**]. A caution appears. Press [**Clear**].
 - f** Press [**Mode/Type**], scroll to the correct transfer line type and press [**Enter**]. A caution appears. Press [**Clear**].
 - g** When prompted to reboot, perform a reboot from the GC keyboard. Press [**Options**], scroll to **Communications**, press [**Enter**], scroll to **Reboot GC?** and press [**On/Yes**] twice.
- 2** Configure the MS on the GC.
 - a** Press [**Config**], scroll to **Mass Selective Detector**, and press [**Mode/Type**].
 - b** On **Unconfigured:**, press [**Mode/Type**], then press [**Enter**].
 - c** When prompted, perform a reboot from the GC keyboard.
- 3** Select the MS type. (Note that you can only enable direct communication when launching MassHunter if an instrument that supports enhanced communication is selected here.)
 - a** Press [**MS/Aux Det**].
 - b** Scroll to **MS type** and press [**Mode/Type**].
 - c** Select the MS model from the list, then press [**Enter**].
- 4** Set MS hardware options for Parts Finder. If your installed source or pump is not listed, leave that item unconfigured. This data helps Parts Finder present parts data specific to your system, so a blank field means only that Parts Finder will show all available choices.
 - a** Press [**MS/Aux Det**].
 - b** Scroll to **Source**, then press [**Mode/Type**].
 - c** Select the source type, then press [**Enter**].
 - d** Scroll to the other entries, and use the [**Mode/Type**] key to select the appropriate options. Available entries include: **Second source**, **HV Pump**, and **Rough pump**. For MS instruments with only one source, set **Second source** to **NOT PRESENT**.
 - e** Scroll to **Serial #** and input the MS serial number. Press [**Enter**].

- 5 If using the Agilent MassHunter data system (version B.07.00 SP2 or greater), skip to the next step. Otherwise, configure the GC IP address on the MS, and configure the MS IP address on the GC.
 - a At the GC, press [**Options**], scroll to **Communications**, and press [**Enter**].
 - b Scroll to **Mass spec.** and press [**Enter**].
 - c Use the keyboard to input the MS IP address.
 - d If the MS supports enhanced communications, input the GC IP address into the MS. See the MS user documentation.
- 6 Open the data system's configuration utility.
- 7 If using the Agilent MassHunter data system (version B.07.00 SP2 or greater):
 - a Configure the GC and MS IP addresses.
 - b Select **Enable Direct Communication between Instruments** and click **OK**.
 - c On the GC keyboard, press [**MS/Aux Det**], and scroll to the **MS Communication** line. The line should now read **On** and a timer will show the length of time GC-MS communications has been active. If the line reads **Disabled**, double-check all parameters, especially the GC and MS IP addresses.

If not using MassHunter version B.07.00 SP2 or greater, use the data system's configuration utility to configure the GC and MS instrument IP addresses. Then, enable GC-MS communications:

- a Press [**MS/Aux Det**] and scroll to **MS Communication**. With communications, disabled, the line should read **MS Communication disabled**.
- b Press [**On/Yes**] to enable communications between the instruments. When the instruments are successfully communicating with each other, the MS Communication line changes to include the current connection uptime.
- c Open the online instrument session and confirm communications between the instruments and the data system.

After establishing GC-MS communications and configuration, next configure GC-HS communications, if applicable, or continue to “Step 4. Connect gases and traps”.

Configuring GC-MS communications (5877B)

After configuring the GC IP address, next configure the MS IP address (if not already done).

Once the instruments have IP addresses and are connected to the LAN, complete the GC/MS configuration and enable enhanced communications, Parts Finder data, and MS-friendly features such as the MS Vent method as follows:

- 1 Press [**Config**] [**MSD/Aux Det**].
- 2 Scroll to **IP**. Enter the numbers of the MSD IP address, separated by dots, and press [**Enter**].
- 3 Scroll to **GW**. Enter the Gateway number and press [**Enter**].
- 4 Scroll to **SM** and press [**Mode/Type**]. Scroll to the appropriate subnet mask from the list given and press [**Enter**].
- 5 Reboot the MSD.
- 6 Press the down arrow to scroll to **Request MSD Reboot?**.
- 7 Press [**On/Yes**] to reboot the MSD and wait for the MSD to complete this cycle before trying to access it.

After establishing GC-MS communications and configuration, next configure GC-HS communications, if applicable, or continue to “Step 4. Connect gases and traps”.

Configuring GC-HS communications

The 7697 headspace sampler can be configured to communicate with the connected GC. This feature requires a HS with firmware A.01.06 (or greater). With communications configured, the HS knows GC method timings and programs, and can synchronize with the GC clock and follow the GC instrument schedule.

To configure GC-HS communications:

- 1 At the headspace sampler keyboard, press [**Options**], then go to **Communications > GC**.
- 2 Enter the GC's IP address, then press [**Enter**].
- 3 At the GC keyboard, press [**Front Injector**] if the headspace sampler is connected to the GC front inlet, or press [**Back Injector**] if it is connected to the GC back inlet.
- 4 Scroll to **No Headspace**, then press [**Mode/Type**]. A list of headspace sampler models appears. Scroll to the correct one, then press [**Enter**].
- 5 Press [**Options**], then select **Communications**.

- 6 Scroll to the IP address entry for the headspace sampler, either **Fr. Headspace** or **Bk. Headspace**. Enter the headspace sampler's IP address.
- 7 Press [**Front Injector**] or [**Back Injector**] as applicable.
- 8 A new **Communication** line appears. Scroll to it and press [**On/Yes**]. The line changes to read **Connected time**. Scroll down to display a read-only summary of the headspace sampler configuration which the GC obtained from the sampler.

If communications fails, check the IP addresses. Verify that the GC's IP address is correct in the headspace sampler, and that the headspace sampler's IP address is correct in the GC. Also check that both instruments are turned on and connected to the LAN. Verify all LAN cable connections.

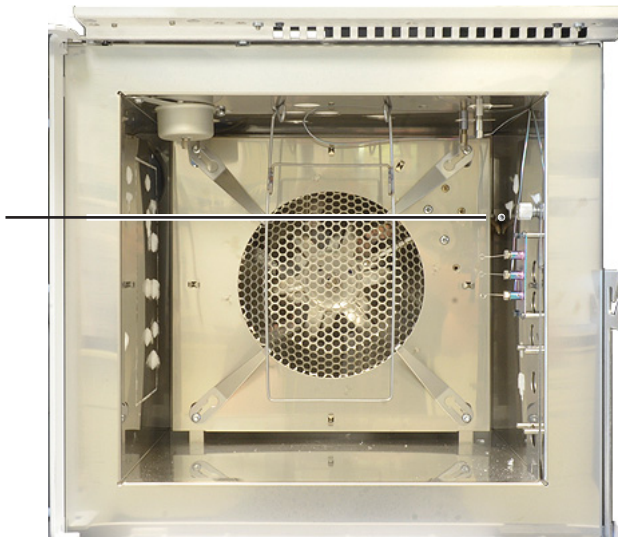
After GC installation, complete HS configuration. Refer to the HS control software help and the HS manuals for information on the configuration options.

Step 13. Calibrate the Hydrogen Sensor

If present, calibrate the hydrogen sensor now. Otherwise, skip to the next step.

- 1 Open the GC oven door and connect a flow meter tube to the sensor tube in the oven.

Connect the flow meter to the hydrogen sensor tube next to the oven heater shroud



- 2 Press [**Options**] then go to **Calibration > Hydrogen Sensor** and press [**Enter**].
- 3 Scroll to **Start Calibration Cycle?** and press [**On/Yes**]. The calibration cycle begins. The hydrogen sensor module will wait to stabilize, then will begin to send calibration gas across the sensor.
- 4 While continuing to measure the flow rate from the tube, adjust the pressure regulator on the calibration gas cylinder until the flow rate is approximately 30 mL/min. Remove the flow meter and close the oven door.

After setting the flow, continue with installation while the calibration completes. (Calibration takes about 5 minutes total time). Hydrogen sensor calibration will not interfere with any other steps.

Step 14. Configure the date/time, pressure units, and the checkout column

You must set the GC date, time, and pressure units, and configure the consumable items (such as the checkout column).

Date and time

- 1 Press [**Config**][**Time**].
- 2 Enter the new time and date. Press [**Enter**].
- 3 Press [**Status**] or any other function key to exit.

Pressure units

- 1 Press [**Options**].
- 2 Scroll to **Keyboard & Display**. Press [**Enter**].
- 3 Scroll to **Pressure units:**. Press [**Mode/Type**].
- 4 Scroll to the desired pressure unit. Press [**Enter**].

Checkout column

The column length, inside diameter, and film thickness are on a metal tag attached to the column.

- 1 Press [**Config**] [**Col 1**] or [**Config**][**Col 2**], or press [**Config**][**Aux Col #**] and enter the number of the column to be configured.
- 2 Scroll to the **Length** line, type the column length, in meters, followed by [**Enter**].
- 3 Scroll to **Diameter**, type the column inside diameter in microns, followed by [**Enter**].
- 4 Scroll to **Film thickness**, type the film thickness in microns, followed by [**Enter**]. The column is now defined.
- 5 Scroll to **Inlet**. Press [**Mode/Type**] to select a gas pressure control device for this end of the column. Selections include the installed GC inlets, and installed Aux and PCM channels.
- 6 Select the appropriate gas pressure control device and press [**Enter**].
- 7 Scroll to **Outlet**. Press [**Mode/Type**] to select a gas pressure control device for this end of the column. Selections include the installed Aux and PCM channels, and detectors. When a detector is selected, the outlet end of the column is controlled at 0 psig for the FID, TCD, FPD, NPD, and uECD or vacuum for the MSD.

Select the appropriate gas pressure control device and press **[Enter]**.

- 8 Scroll to **Thermal zone**. Press **[Mode/Type]** to see the available choices. In most cases this will be **GC oven**, but you may have an MSD transfer line heated by an auxiliary zone, valves in a separately-heated valve box or other configurations.

Select the appropriate **Thermal zone** and press **[Enter]**.

This completes configuration for a single capillary column. Also see the [Operation](#) manual for more information about configuring columns.

Step 15. Install the checkout column to the inlet and condition

A capillary column was shipped with the GC to be used to confirm proper operation. Agilent suggests that it be used only for that purpose.

WARNING

To condition a column using hydrogen carrier gas, either connect the column to a detector that will combust it (and ignite the flame), or vent the end of the column to a fume hood. Hydrogen flowing into the oven through the open column end creates an explosion hazard. Refer to the [7890 Series GC Safety Manual](#) and [Maintaining Your GC](#) manual for details and instructions.

The column must be conditioned to remove any contaminants before it is used.

- 1 Locate the installation instructions for the column and inlet you will use. See the [Maintaining Your GC](#) manual. Refer to the sections on your specific inlet and detector types.
 - [Split/splitless](#)
 - [Multimode](#)
 - [Purged packed](#)
 - [Cool on-column](#)
 - [PTV](#)
 - [Volatiles interface](#)
- 2 Install the column in the inlet. Do not connect it to a detector.
- 3 If using a flammable carrier gas (hydrogen), vent the column exhaust to a fume hood. (Prevent hydrogen gas accumulation in the GC.)
- 4 Turn on the carrier gas.
- 5 If using a split/splitless or multimode inlet, perform an Inlet Leak Check. Press [**Service Mode**], then select **Front inlet leak check** or **Back inlet leak check**. Press **Enter** to start the check. If the check fails, tighten connections.
- 6 Refer to the conditioning instructions that shipped with the checkout column. Note the oven temperature, average velocity or flow, and so on.
- 7 Leave the detector end of the column unattached.
- 8 Set the oven temperature and inlet flow conditions specified for conditioning the column.

1 Installing the GC

- 9** Condition for the time given in the column's instructions.
- 10** Cool the oven.
- 11** Leave the carrier gas on. If using a flammable carrier gas (hydrogen), continue to vent the column exhaust to a fume hood. (Prevent hydrogen gas accumulation in the GC.)

Step 16. Bakeout the detector

- 1 Locate the bakeout instructions for the detector you will use. See the [Maintaining Your GC](#) manual. Refer to the section on your specific detector type.
 - FID
 - TCD
 - NPD
 - μ ECD
- 2 Install a cap on the detector's column fitting to prevent the flow of detector gases into the oven.
- 3 Turn the detector gases on. Light the flame, if appropriate.
- 4 Heat the detector to the temperature given in the bakeout instructions, and hold at temperature for the time given in the instructions.

Step 17. Cool the detector and complete column installation

- 1 Locate the installation instructions for the column and detector you will use. See the [Maintaining Your GC](#) manual. Refer to the section for your specific detector type.
 - FID
 - TCD
 - NPD
 - μ ECD
 - FPD+
- 2 Connect the free end of the checkout column to the detector, as described in *Maintaining Your GC*.

Step 18. If appropriate, update firmware

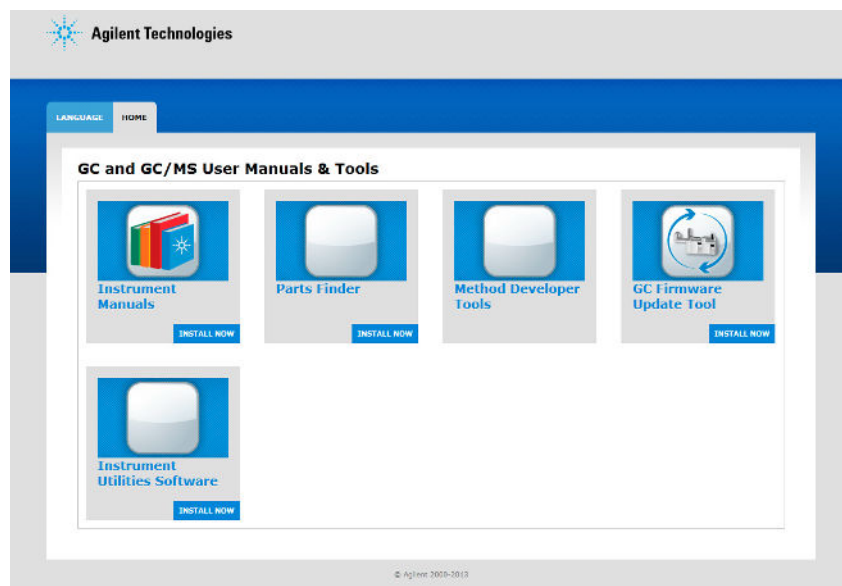
Firmware maintenance is an ongoing process. Updates are posted on the Agilent web site and may be downloaded to the GC using the Firmware Update Utility or the Agilent Instrument Utilities software. Two kinds of firmware can be downloaded:

- Firmware that controls the general operation of the GC.
- PID constants for the electronic pressure control (EPC) functions of the GC. (Agilent service personnel only.)

While the GC shipped with the latest firmware version available when it was manufactured, Agilent recommends that you check for any updates and install them if available.

GC firmware

- 1 Install the **Firmware Update Tool**.
 - a Place the *Agilent GC and GC/MS User Manuals & Tools* DVD into your PC's DVD drive.
 - b Open file <D:>/index.html, where <D:> is the name of the DVD drive.



- c Click the **GC Firmware Update Tool** icon.
 - d Read the instructions, then install the utility as described.
- 2 Check the GC firmware version. On the GC keyboard, press [**Status**][**Clear**]. The display shows the current firmware version.

- 3 Check for any available firmware updates. Go to the Agilent web site at http://www.chem.agilent.com/_layouts/agilent/downloadFirmware.aspx?whid=50307.
 - If the available firmware version is newer than the version on the GC, download it.
 - If not, skip to the next section.
- 4 Verify that if a new firmware version is available, it is compatible with the current hardware and software. For example, verify that any data system is compatible with the new firmware. If the new firmware is not compatible or acceptable for any reason, skip to “PIDs” below.
- 5 If available, install any available firmware updates.

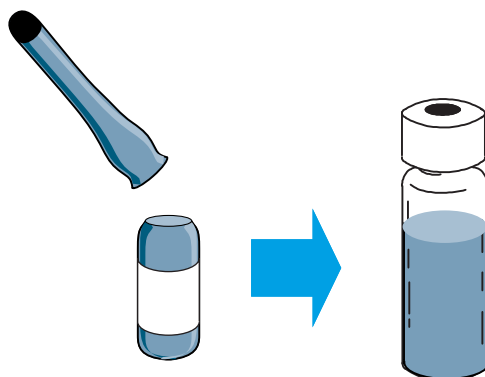
PIDs

You may need to update or change the PIDs for any AUX EPC or PCM module installed in the GC:

- If the system includes an AUX EPC module for a CFT device (Dean's switch, purged splitter, or so on) or headspace application, use the Firmware Update Utility or Instrument Utilities to update the AUX module PID constants according to the application instructions. (Required)
- If the system includes a PCM module for controlling the backpressure to a headspace sampling loop, use the Firmware Update Utility or Instrument Utilities to update the PCM module PID constants according to the application instructions. (Required)

Step 19. Transfer the checkout sample to a screw-top sample vial

- 1 The checkout sample is contained in sealed glass vials. Wrap a piece of cloth or a paper towel around the vial to protect your fingers and snap the top off.



- 2 Use a pipette to transfer the sample to a 2-mL screw-top vial. (If using an ALS, use a vial suitable for the ALS turret or tray.)

Step 20. When the system stabilizes, run one injection

Perform the checkout procedure as described in "Chromatographic Checkout" in the *Operation Manual*.

- 1 Enter the parameters for the checkout procedure.
 - If using an Agilent data system, use it to create a checkout method.
 - If not using a data system, enter the setpoints using the GC keyboard.

See the following topics in the *Operation Manual* for the parameters for your detector:

- FID checkout
 - FPD⁺ checkout
 - FPD⁺ checkout (Japan)
 - NPD checkout
 - TCD checkout
 - μ ECD checkout
- 2 When the GC becomes Ready (**Not ready** light turns off), make the injection and start the run.
 - For an ALS injection, press **[Start]** on the GC or in the data system, as appropriate.
 - For a manual injection, inject the sample and press **[Start]**.

Step 21. Evaluate Results

Compare the chromatogram you generated with the one in the checkout procedure. There should be a close resemblance.

Prepare for the Next Analysis

After evaluating the GC under the checkout conditions, installation checkout is complete. The next step is to prepare the GC for your next analysis. Be sure to cool the GC before making changes. See the 7890 Series [Maintaining Your GC](#) manual and the 7890 Series [Operation Manual](#).

- Install the appropriate inlet hardware (can include septum, liner, liner-O-ring, inlet gold seal, inserts, and so on).
- Install the appropriate detector hardware (wavelength filter for FPD⁺, jet for FID or NPD).
- Change to any alternate gas sources as needed for the new analysis.
- Install the desired column and condition it per the manufacturer's recommendations.
- Configure the GC to match any hardware or gas type changes (columns, liners, carrier or makeup gas types, and so on).
- Load or create the desired method.



A Making Swagelok Connections

Making Swagelok Connections 72

Using a Swagelok Tee 75

The gas supply tubing is attached with Swagelok fittings. If you are not familiar with Swagelok connections, review the following procedures.



Making Swagelok Connections

Objective

To make a tubing connection that does not leak and that can be taken apart without damaging the fitting.

Materials needed:

- 1/8-inch (or 1/4-inch, if used) preconditioned copper tubing
- 1/8-inch (or 1/4-inch, if used) Swagelok nuts
- Front and back ferrules
- Two 7/16-inch (for 1/8-inch nuts) or 9/16-inch (for 1/4-inch nuts) wrenches

- 1 Place a Swagelok nut, back ferrule, and front ferrule to the tubing as shown in [Figure 17](#).

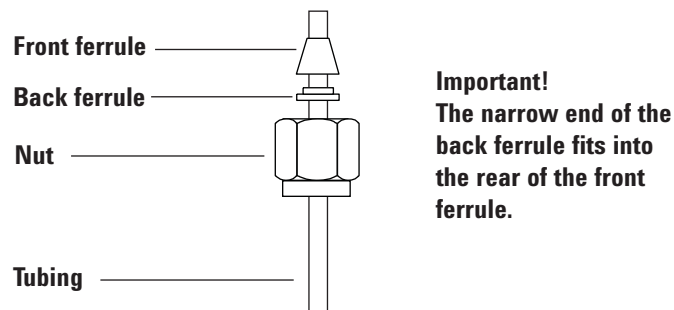


Figure 17 Swagelok nuts and ferrules

- 2 Clamp a stainless steel plug or similar fitting in a bench vise.

CAUTION

Use a separate stainless steel fitting in a vise for initial tightening of the nut. Do not use an inlet or detector fitting. Strong forces are required to properly set the ferrules, and damage to an inlet or detector fitting is very costly to repair.

- 3 Push the tubing into the stainless steel plug (see [Figure 18](#)).

- 4 Make sure that the front ferrule is touching the plug. Slide the Swagelok nut over the ferrule and thread it onto the plug.

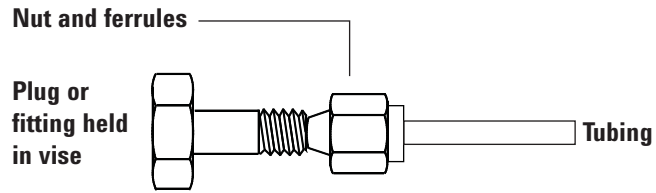


Figure 18 Assembling the fitting

- 5 Push the tube fully into the plug, then withdraw it approximately 1 to 2 mm (see Figure 19).

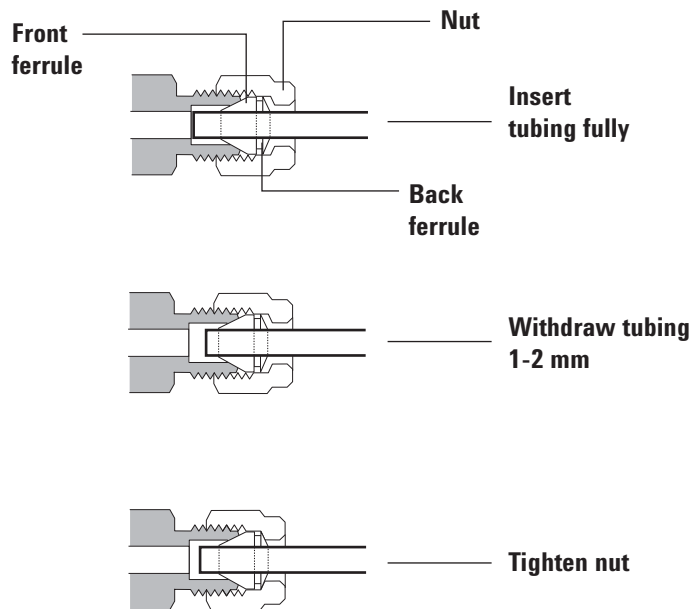


Figure 19 Insert the tubing

- 6 Finger-tighten the nut.

- 7 Mark the nut with a pencil line (see Figure 20).

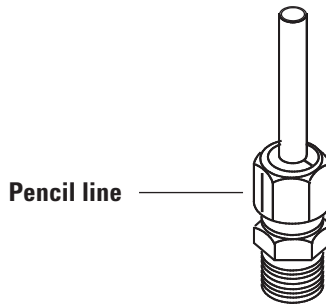


Figure 20 Marking the fitting

- 8 For 1/8-inch Swagelok fittings, use a pair of wrenches to tighten the fitting 3/4 of a turn (see Figure 21).

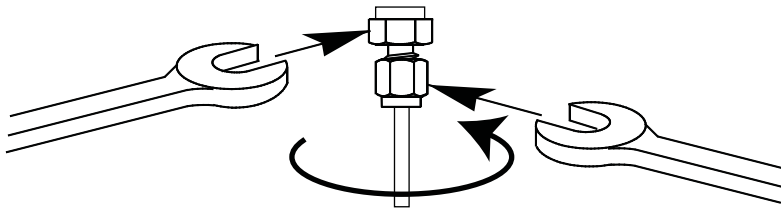


Figure 21 Final tightening

- 9 Remove the plug from the fitting. To connect the tubing, with nut and ferrules, to another fitting, finger-tighten the nut, then use a wrench to tighten it 3/4 (1/8-inch fittings) of a turn.
- 10 Both correctly- and incorrectly-swaged connections are shown in Figure 22. Note that the end of the tubing in a correctly-swaged fitting is not crushed and does not interfere with the action of the ferrules.

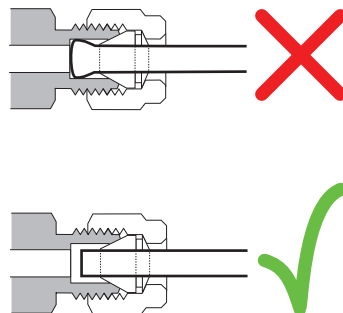


Figure 22 Completed fitting

Using a Swagelok Tee

To supply gas from a single source to more than one input, use a Swagelok Tee.

NOTE

Do not combine valve actuator air with flame ionization air. The valve action will cause major upsets in the detector signal.

Materials needed:

- 1/8-inch preconditioned copper tubing
- Tubing cutter
- 1/8-inch Swagelok nuts and front and back ferrules
- 1/8-inch Swagelok Tee
- Two 7/16-inch wrenches
- 1/8-inch Swagelok cap (optional)

- 1 Cut the tubing where you want to install the Tee. Connect the tubing and Tee with a Swagelok fitting. See [Figure 23](#).

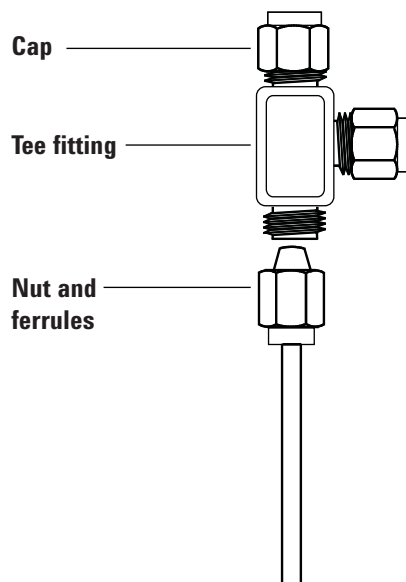
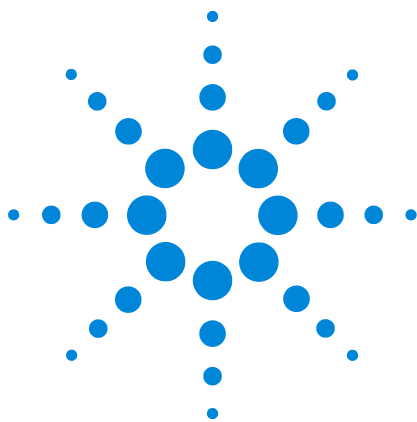


Figure 23 Swagelok tee

- 2 Measure the distance from the Tee to the instrument fittings. Attach copper tubing to the open Tee ends with Swagelok fittings.

A Making Swagelok Connections



B **Cabling Diagrams and Remote Start/Stop**

Using the Remote Start/Stop Cable 78

Multi-instrument Cabling Examples 81

Cable Diagrams 86

This section lists cabling requirements and connection diagrams that apply to less common or specialized GC installations.



Using the Remote Start/Stop Cable

Remote start/stop is used to synchronize two or more instruments. For example, you might connect an integrator and the GC so that the [**Start**]/[**Stop**] buttons on either instrument control both of them. You can synchronize a maximum of ten instruments using Remote cables.

Connecting Agilent products

If connecting two Agilent products with Remote cables, the sending and receiving circuits will be compatible—just plug in both ends of the cable.

Connecting non-Agilent products

If connecting to a non-Agilent product, the following paragraphs contain information you will need to ensure compatibility.

APG Remote signal electrical specifications

The APG signals are a modified open collector type. The signal levels are generally TTL levels (low voltage is logic zero, high voltage is logic one) but the open circuit voltage will be between 2.5 and 3.7 V. The typical voltage is 3 V. A voltage over 2.2 V will be interpreted as a high logic state while a voltage below 0.4 V will be interpreted as a low logic state. These levels provide some margin over the specifications of the devices used.

The pull-up resistance, connected to the open-circuit voltage, is in the range of about 1 kOhms to 1.5 kOhms. For a logic-low state, for a single device on the bus, the minimum current you must be able to sink is 3.3 mA. Since devices are connected in parallel, when you have multiple devices this minimum current must be multiplied by the number of devices attached on the bus. The maximum voltage for a low-input state is 0.4 V.

The bus is passively pulled high. Leakage current out of a port must be less than 0.2 mA to keep the voltage from being pulled lower than 2.2 V. Higher leakage current may cause the state to be interpreted as a low.

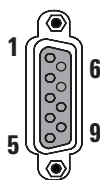
Over-voltage protection: APG Remote connections are clamped by a zener diode to 5.6 V. Exceeding this voltage will damage the circuit (GC logic board).

APG Remote - Suggested drive circuits

A signal on the APG bus may be driven by another APG device or by one of the following circuits:

- A relay, with one side connected to ground, when closed will set a logic-low state.
- An NPN transistor, with the emitter connected to ground and the collector connected to the signal line will set a logic-low state if proper base current is supplied.
- An open-collector logic gate will perform this same function.
- A low-side drive IC will also work, but Darlington-type drivers should be avoided as they will not meet the low-side voltage requirement of less than 0.4 V

APG Remote connector



Pin	Function	Logic
1	Digital ground	
2	Prepare	LOW true
3	Start	LOW true (output)
4	Start relay	
5	Start relay	
6	Not used	
7	Ready	HIGH true (output)
8	Stop	LOW true
9	Not used	

APG Remote signal descriptions

Prepare (Low True) Request to prepare for analysis. Receiver is any module performing pre-analysis activities. For example, shorting pin 2 to ground will put the GC into **Prep Run** state. This is useful for Splitless Mode to prepare the inlet for injection or when using **Gas Saver**. This function is not needed by Agilent autosampler systems.

Ready (High True) If the Ready line is high (> 2.2 VDC) then the system is ready for next analysis. Receiver is any sequence controller.

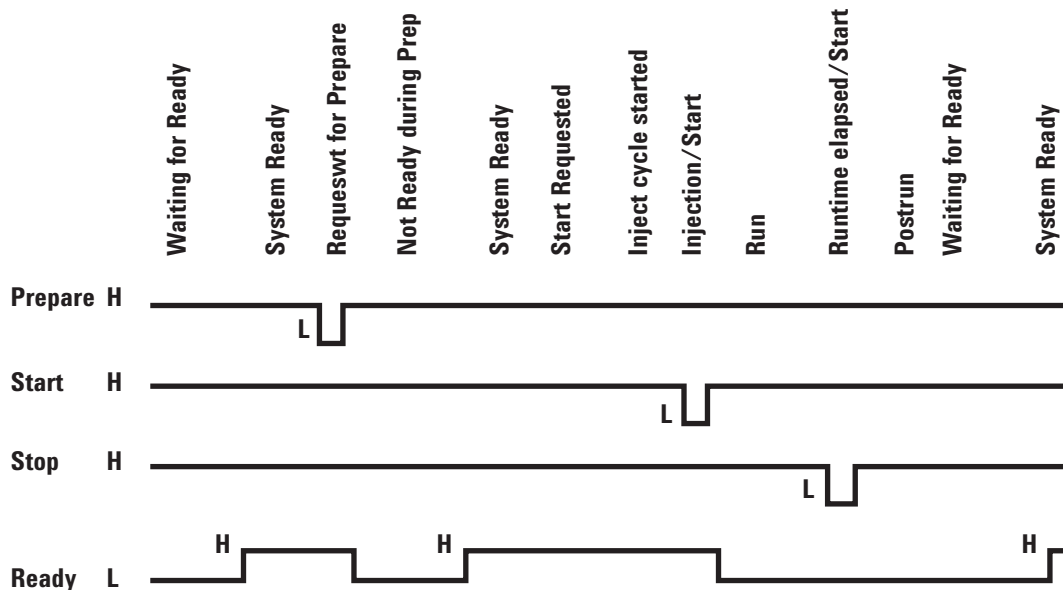
B Cabling Diagrams and Remote Start/Stop

Start (Low True) Request to start run/timetable. Receiver is any module performing runtime-controlled activities. The 7890 Series GC requires a pulse duration of at least 500 micro-seconds to sense a start from an external device.

Start Relay (Contact Closure) A 120 millisecond contact closure used as an isolated output to start another device that is not compatible or connected with APG Remote pin 3.

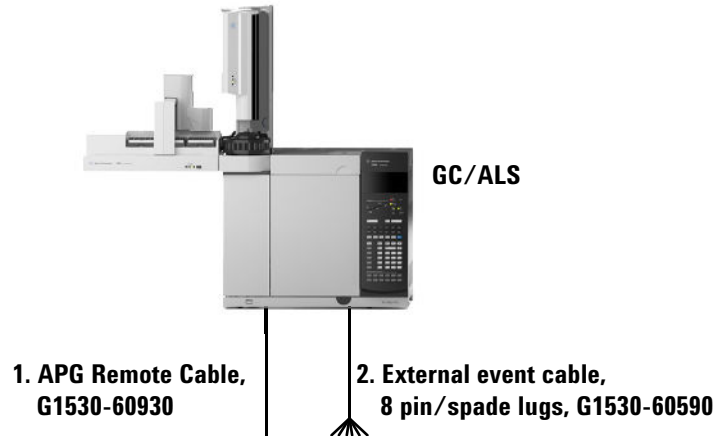
Stop (Low True) Request to reach system ready state as soon as possible (for example, stop run, abort or finish, and stop injection). Receiver is any module performing runtime-controlled activities. Normally this line is not connected, if the GC oven program is used to control the method **Stop** time.

APG Remote timing diagram



Multi-instrument Cabling Examples

GC / ALS / Non-Agilent Data System



Number	Part number and description
1	G1530-60930, General use APG remote cable, 9-pin male/spade lug (0.5m)
2	G1530-60590, External event cable, 8-pin/spade lugs
	G1580-87200, Caution label, Events cable, green in color

35900-60670 APG remote cable spade lug identification			G1530-60590 External event cable spade lug identification		
Connector 1 9 pin (male)	Signal name	Connector 2 spade lugs	Pin	Color	Signal
1	GND	Black	1	Yellow	24 V Out 1
2	Prepare	White	2	Black	24 V Out 2
3	Start	Red	3	Red	Ground
4	Shut down	Green	4	White	Ground
5	Reserved	Brown	5	Orange	Contact 1
6	Power on	Blue	6	Green	Contact 1
7	Ready	Orange	7	Brown	Contact 2
8	Stop	Yellow	8	Blue	Contact 2
9	Start Request	Violet			

GC / 3395A/3396B Integrator / ALS

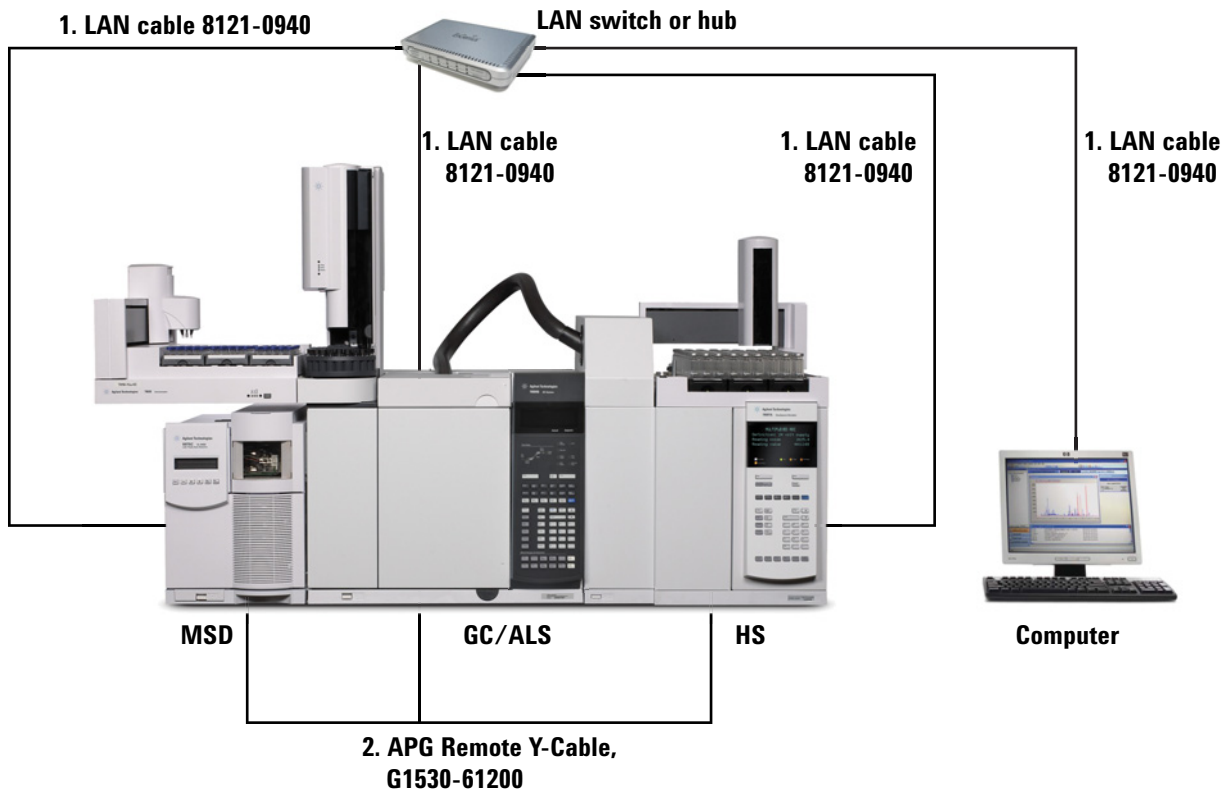


Number	Part number and description
1	03396-61010, 2-m APG remote cable, 9-pin/15-pin
2	G1530-60570, 2-m Analog cable, 6-pin

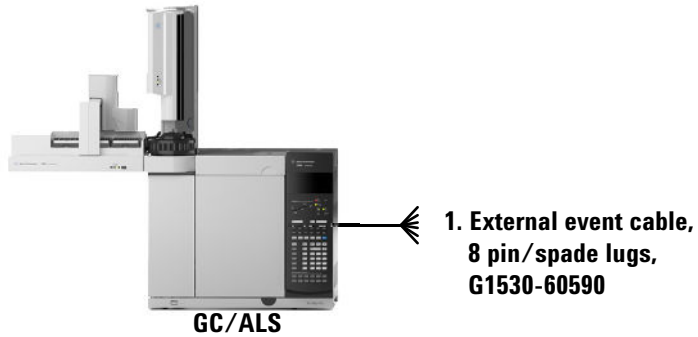
GC / 3396C Integrator / ALS

Number	Part number and description
1	G1530-60930, 2-m APG remote cable, 9-pin male/9-pin male
2	G1530-60570, 2-m Analog cable, 6-pin

Example: Using a Y-Cable in a setup (GC/MSD/Data System/Headspace Sampler)



Number	Part number and description
1	G1530-61200, 2-m Y-cable, remote start/stop
2	8121-0940, Cable, LAN, 25 foot

GC / External Events (unspecified, non-Agilent instrument)

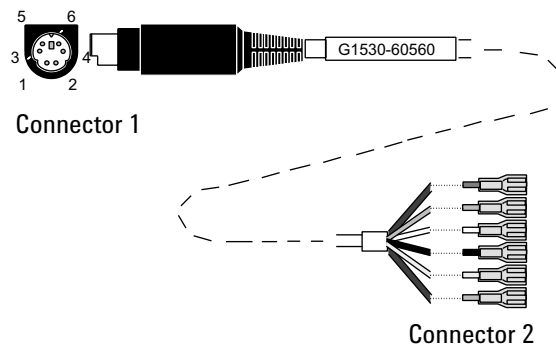
Number	Part number and description
1	G1530-60590, External events cable, 8-pin/spade lugs
	G1580-87200, Caution label, Events cable, green in color

Connector	Signal name	Maximum rating	Wire color	Corresponds to valve #
24 volt control output				
1	24 volt output 1	150 mA output	Yellow	5
2	24 volt output 2	150 mA output	Black	6
3	Ground		Red	
4	Ground		White	
Relay contact closures (normally open)				
5	Contact closure 1	48V AC/DC, 250 mA	Orange	7
6	Contact closure 1		Green	7
7	Contact closure 2	48 V AC/DC, 250 mA	Brown or violet	8
8	Contact closure 2		Blue	8

Cable Diagrams

Analog signal cable, general use, G1530-60560

Connects GC signal outputs to non-Agilent products. Also used for the Analog Input Board (AIB).



The pin assignments for the general use analog out cable are listed in [Table 10](#).

Table 10 Analog cable, general use, output connections

Connector 1	Connector 2, wire color	Signal
1	Brown or violet	Not used
2	White	0 to 1 V, 0 to 10 V (-)
3	Red	Not used
4	Black	1 V (+)
6	Blue	10 V (+)
Shell	Orange	Ground

Agilent analog signal cable, G1530-60570

This cable connects an **Analog out** port to an external data system. Both 0 to 1 volt and 0 to 10 volts are provided. Connects both GC signal outputs to Agilent 3395B/3396C integrators, and the 35900 A/D.

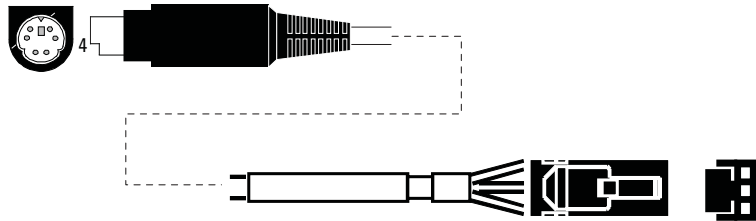
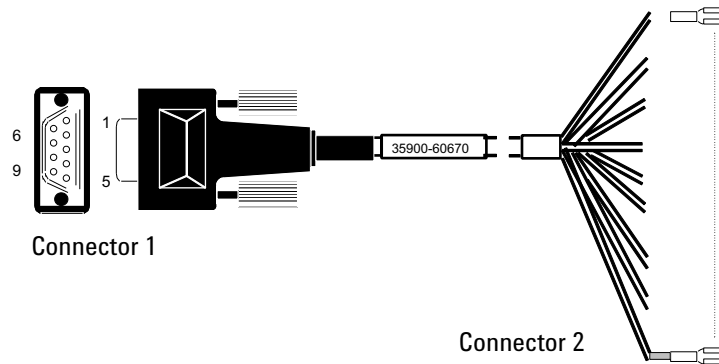


Figure 24 Analog output cable to an Agilent product

Remote start/stop cable, general use, 35900-60670



The pin assignments for the remote start/stop cable are listed in [Table 11](#).

Table 11 Remote start/stop cable connections

Connector 1, 9-pin male	Connector 2, wire color	Signal
1	Black	Digital ground
2	White	Prepare (low tone)
3	Red	Start (low tone)
4	Green	Start relay (closed during start)

Table 11 Remote start/stop cable connections (continued)

Connector 1, 9-pin male	Connector 2, wire color	Signal
5	Brown	Start relay (closed during start)
6	Blue	Open circuit
7	Orange	Ready (high true input)
8	Yellow	Stop (low tone)
9	Violet	Open circuit

Agilent APG remote start/stop cable, 03396-61010

Synchronizes the GC with an Agilent integrator. Additional cables may be used to add more instruments (up to 10 total).

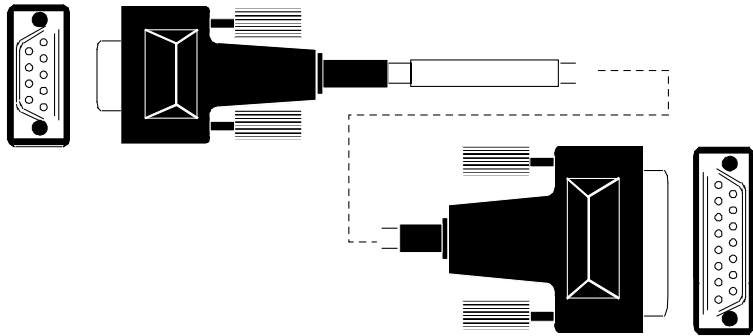


Figure 25 Remote start/stop cable, GC to Agilent integrator

Agilent APG remote start/stop cable, G1530-60930

Synchronizes the GC with another Agilent instrument.
Additional cables may be used to add more instruments (up to 10 total).

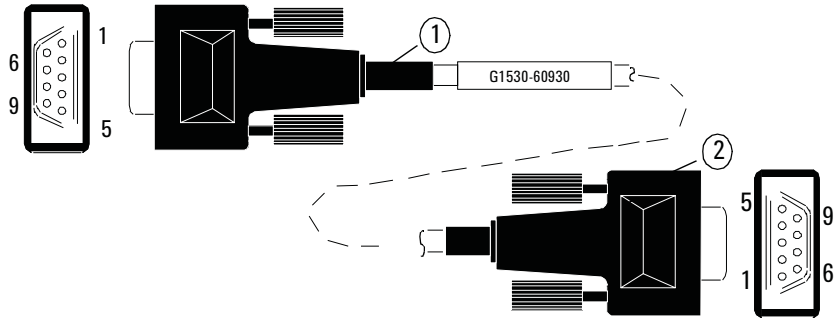


Figure 26 Remote start/stop cable, GC to Agilent instrument

Agilent remote start/stop Y-cable, G1530-61200

Synchronizes the GC with another 2 Agilent instruments.

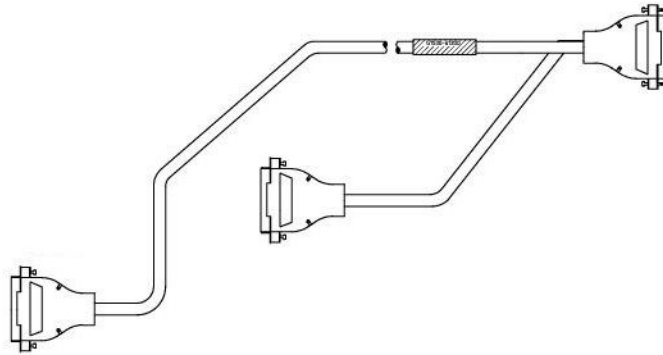


Figure 27 Remote start/stop cable, GC to Agilent instrument

BCD cable, G1530-60590



The BCD cable connector has eight passive inputs that sense total binary-coded decimal levels. The pin assignments for this connector are listed in [Table 12](#).

Table 12 BCD input connections

Pin	Function	Maximum rating
1	Relay	48 V AC/DC, 250 mA
2	Relay	48 V AC/DC, 250 mA
3	LS digit 0	
4	LS digit 1	
5	LS digit 2	
6	LS digit 3	
7	MS digit 0	
8	Ground	
Shield	Chassis ground	

When used for BCD input, apply label G1580-87100 to identify the cable for BCD use.

BCD cable, G1530-61100

The BCD cable connector has eight passive inputs that sense total binary-coded decimal levels. The pin assignments for this connector are listed in [Table 12](#).

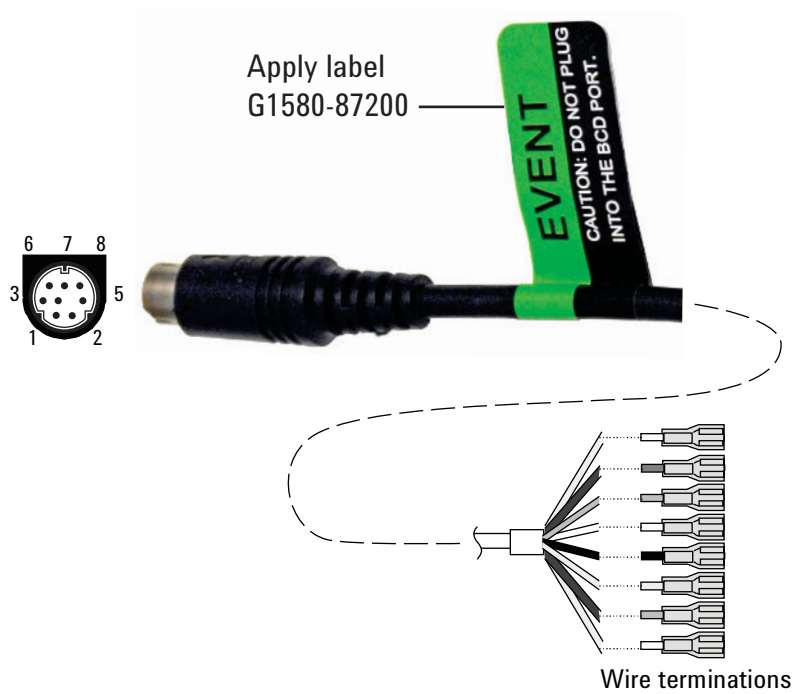
Table 13 BCD cable connections

Connector 1 Pin	Connector 2 Pin	Ribbon Cable Wire Color
1	1	Brown
	2	Red
	3	Orange
	4	Yellow
	5	Green
	6	Blue
	7	Violet
	8	Gray
2, 8	9	White
	10	Black
6	11	Brown
	12	Red
5	13	Orange
	14	Yellow
4	15	Green
	16	Blue

Table 13 BCD cable connections (continued)

Connector 1 Pin	Connector 2 Pin	Ribbon Cable Wire Color
7	17	Violet
3	18	Gray
	19	White
	20	Black
	21	Brown
	22	Red
	23	Orange
	24	Yellow
	25	Green
	26	Blue

External event cable, G1530-60590



The external event cable has two passive relay contact closures with two 24-volt control outputs. Devices connected to the passive contact closures must be connected to their own power sources.

The pin assignments for this cable are listed in [Table 14](#).

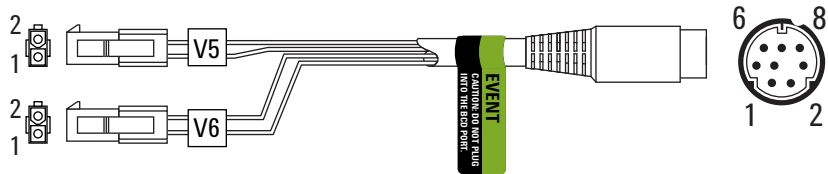
Table 14 External events cable

Connector 1 pin	Signal name	Maximum rating	Connector 2, wire color	Controlled by valve #
24 volts output				
1	24 V output 1	150 mA	Yellow	5
2	24 V output 1	150 mA	Black	6
3	Ground		Red	
4	Ground		White	
Relay contact closures (normally open)				
5	Closure 1	48 V AC/DC, 250 mA	Orange	7
6	Closure 1		Green	7
7	Closure 2	48 V AC/DC, 250 mA	Brown or violet	8
8	Closure 2		Blue	8

When used for external event control, apply label G1580-87200 to identify the cable for EVENT use.

External valve cable, G1580-60710

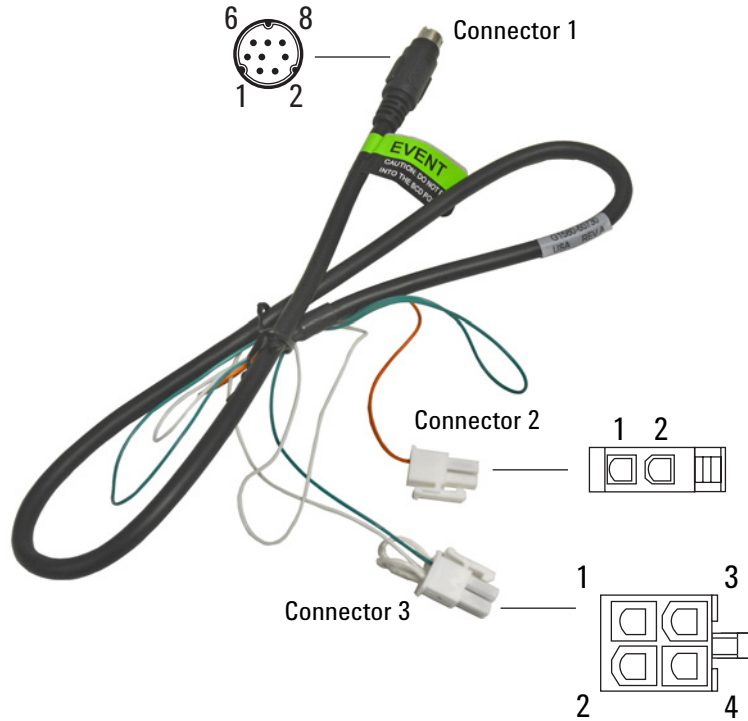
Supplies power for certain valve applications.



Connector 1 pin	Wire color	Connector and pin	Function
1	Yellow	V5 pin 1	24 V, 150 mA max.
2	Black	V6 pin 1	24 V, 150 mA max.
3	Red	V5 pin 2	Ground
4	White	V6 pin 2	Ground
5			
6			
7			
8			

Pulser module power supply cable, G1580-60730

Supplies power for a PDHID pulser module.



Connector 1 pin	Wire color	Connector and pin	Function
1	Yellow		
2	Black		
3	Red		
4	White	Connector 3 pin 1*	Ground
5	Orange	Connector 2 pin 1	Contact closure 1, 48 V AC/DC, 250 mA
6	Green	Connector 3 pin 3	Contact closure 1
7	Brown		
8	Blue		

* Connector 3: Pin1 is jumpered to pin 2. Pin 2 is jumpered to pin 4.