



Agilent 5977 Series MSD

Laboratory Operator Quick Reference Guide



**Ion Source
Routine Maintenance
Venting and Pump Down**



Agilent Technologies

Ion Source Cleaning

Clean the parts that contact the sample or ion beam. The other parts normally should not require cleaning.

If the contamination is serious, such as an oil backflow into the analyzer, seriously consider replacing the contaminated parts.

Abrasively clean the surfaces that contact the sample or ion beam.

Use an abrasive slurry of alumina powder and reagent-grade methanol on a cotton swab. Use enough force to remove all discolorations. Polishing the parts is not necessary; small scratches will not harm performance. Also abrasively clean the discolorations where electrons from the filaments enter the source body.

Rinse away all abrasive residue with reagent-grade methanol.

Take care to avoid recontaminating cleaned and dried parts. Put on new, clean gloves before handling the parts. Do not set the cleaned parts on a dirty surface. Set them only on clean, lint-free cloths.

NOTE

The main effect of operating the MSD in CI mode is the need for more frequent ion source cleaning. In CI operation, the ion source chamber is subject to more rapid contamination than in EI operation because of the higher source pressures required for CI.

CAUTION

Do not overtighten the repeller nut or the ceramic repeller insulators will break when the source heats up. The nut should only be finger-tight.

CAUTION

If insulators are dirty, clean them with a cotton swab dampened with reagent-grade methanol. If that does not clean the insulators, replace them. Do not abrasively or ultrasonically clean the insulators.

CAUTION

The filaments, source heater assembly, and insulators cannot be cleaned ultrasonically. Replace these components if major contamination occurs.

EI Ion Source - Stainless or Inert

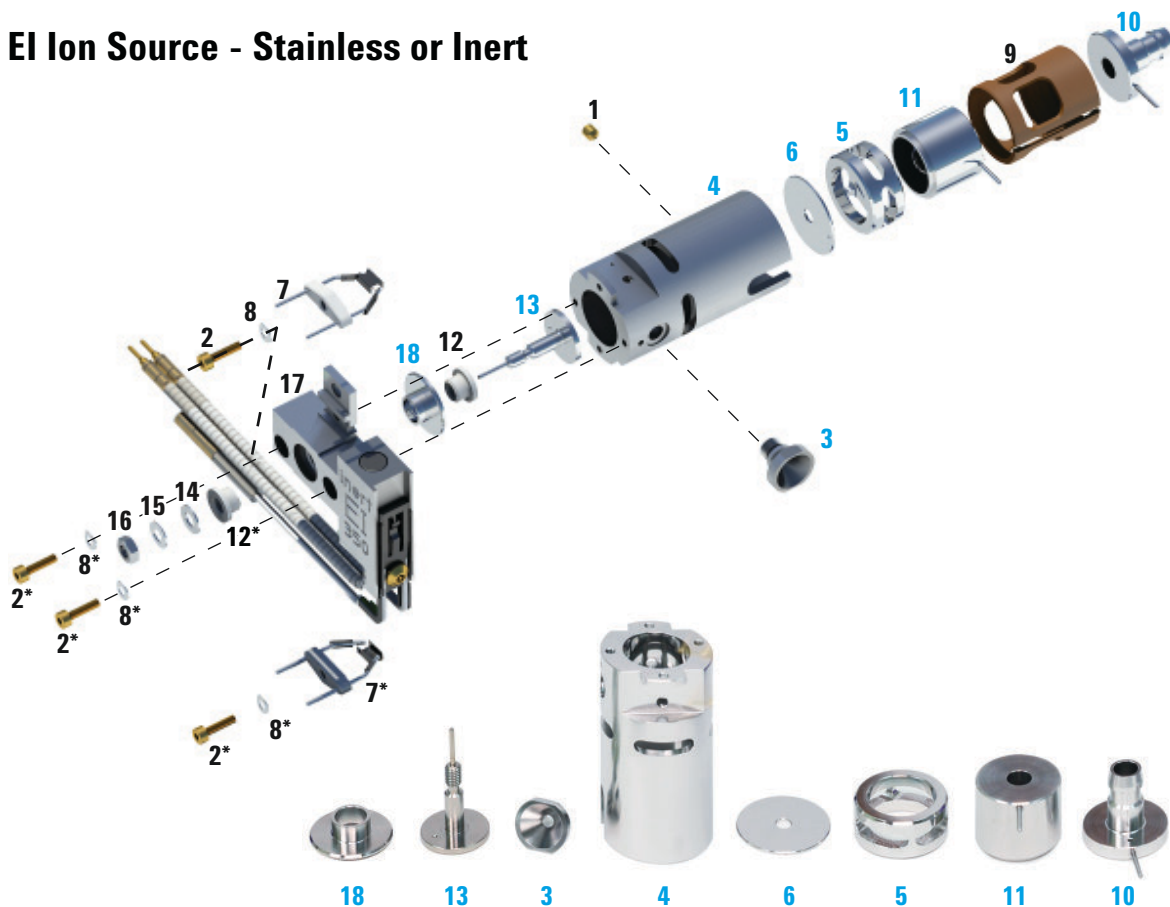

Clean the parts highlighted in blue.

- | | | |
|-------------------------|-----------------------|---------------------------------|
| 1 Gold plated set screw | 7 4-turn filament | 13 Repeller |
| 2 Gold plated screw | 8 Spring washer | 14 Flat washer |
| 3 Interface socket | 9 Lens insulator | 15 Belleville spring washer |
| 4 Source body | 10 Entrance lens | 16 Repeller nut |
| 5 Drawout cylinder | 11 Ion focus lens | 17 Source heater block assembly |
| 6 Drawout plate | 12 Repeller insulator | 18 Repeller block insert |

El Ion Source - Extractor

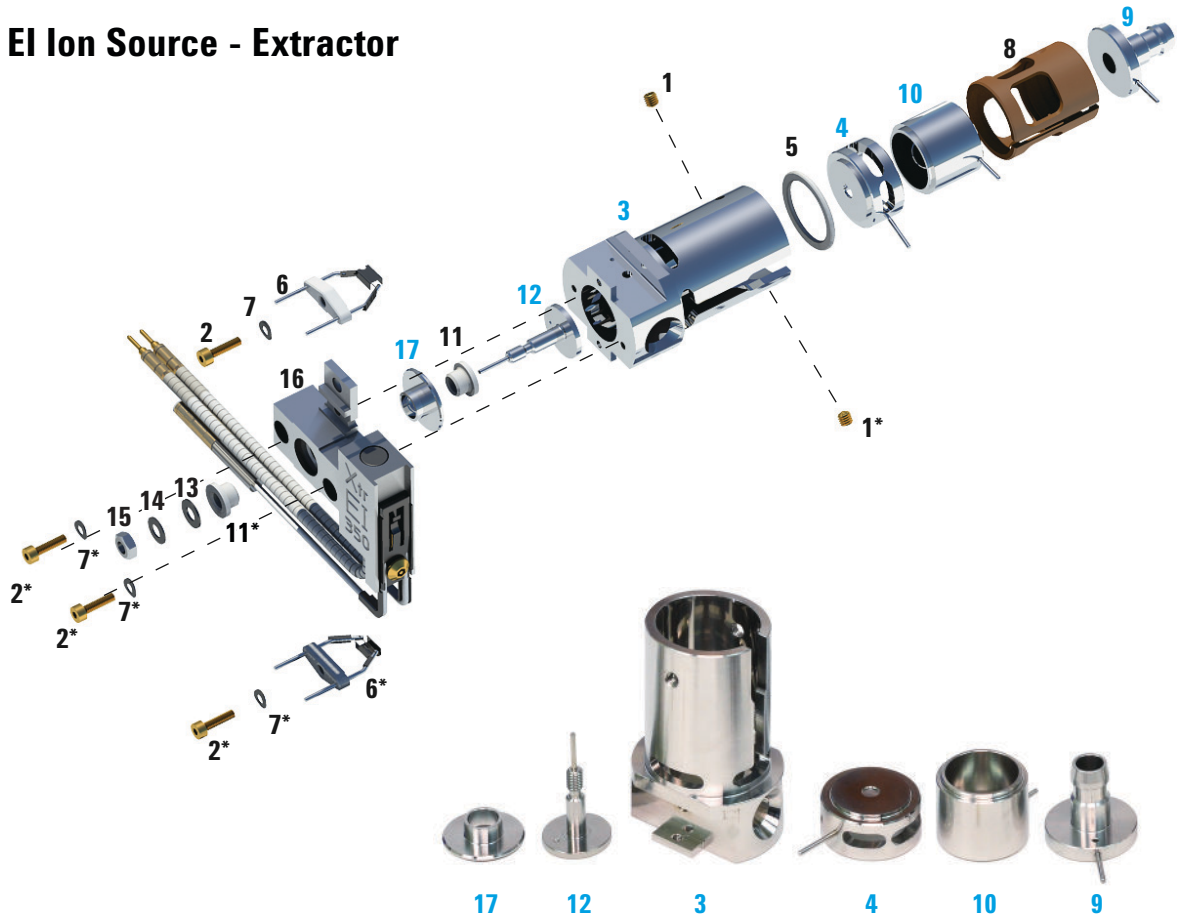

Clean the parts highlighted in blue.

- | | | | | | |
|---|--------------------------|----|--------------------|----|------------------------------|
| 1 | Set screws | 7 | Spring washer | 13 | Flat washer |
| 2 | Screws | 8 | Lens insulator | 14 | Belleville spring washer |
| 3 | Source body | 9 | Entrance lens | 15 | Repeller nut |
| 4 | Extractor lens | 10 | Ion focus lens | 16 | Source heater block assembly |
| 5 | Extractor lens insulator | 11 | Repeller insulator | 17 | Repeller block insert |
| 6 | Filaments | 12 | Repeller | | |

Cl Ion Source

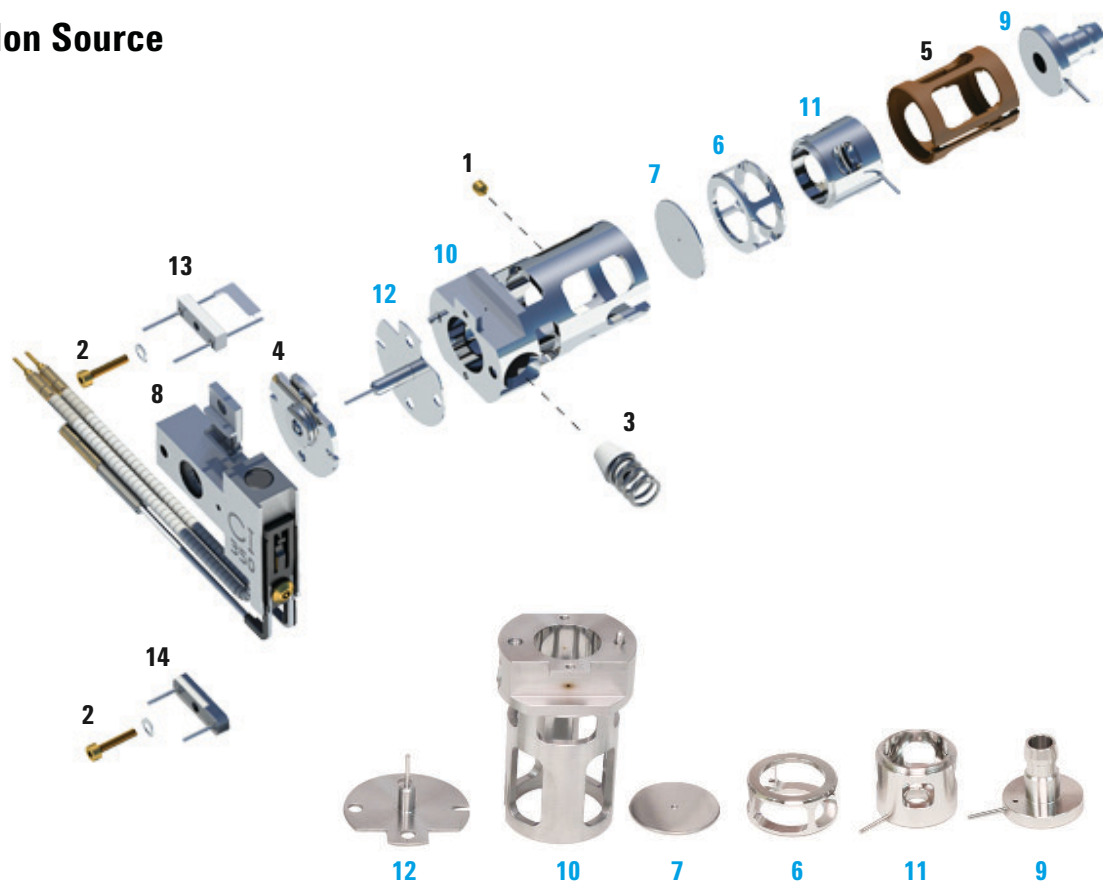

Clean the parts highlighted in blue.

- | | | | | | |
|---|-----------------------|----|---------------------------------|----|-------------------|
| 1 | Set screw | 6 | Cl drawout cylinder | 11 | Cl ion focus lens |
| 2 | Filament screw | 7 | Cl drawout plate | 12 | Cl repeller |
| 3 | Cl interface tip seal | 8 | Cl source heater block assembly | 13 | Cl filament |
| 4 | Cl repeller insulator | 9 | Entrance lens | 14 | Dummy filament |
| 5 | Cl lens insulator | 10 | Cl source body | | |

Operating the MSD from the LCP

The local control panel (LCP) shows the status of the MSD or initiates a task on the MSD without using the Agilent MassHunter Data Acquisition software. MS parameters cannot be set from the LCP while an online Mass Hunter Data Acquisition session is connected to the MSD.

To access a menu option, press [**Menu**] until the desired menu appears, then press [**Item**] until the desired menu item appears.

Maintenance menu

Action	Description
Prepare to vent	Reminds you to shut down the GC then prepares the instrument for venting when [Yes/Select] is pressed.
Pumpdown	Initiates a pumpdown sequence.
Hi Vac Soft Start	Allows you to connect or disconnect the hi vac soft start feature. This feature slowly ramps up the turbo pump speed, and should be used after the pump has sat idle for a few weeks to minimize wear on the pump.

MS Parameters menu

Action	Description
High Vacuum Pressure	Only with Micro-Ion vacuum gauge installed.
Turbo Pump Speed	Displays the turbo pump speed.
MSD Fault Status	Reports a summary fault status code (number) in 'dec' (decimal) and 'hex' (hexadecimal) format covering all possible fault combinations.
Ion Source Temp, °C	Displays and sets the ion source temperature.
Quadrupole Temp, °C	Displays and sets the quadrupole temperature.
CI Reagent	Displays CI reagent gas and flow rate (if installed).

Pumping Down

The data system or local control panel helps you pump down the MSD. The process is mostly automated. Once you close the vent valve and turn on the main power switch (while pressing on the sideplate), the MSD pumps down by itself. The data system software monitors and displays system status during pumpdown. When the pressure is low enough, the program turns on the ion source and mass filter heaters and prompts you to turn on the GC/MSD interface heater. The MSD will shut down if it cannot pump down correctly.

Using the menus or MS monitors, the data system can display:

- Motor speed for turbo pump MSDs (percent spin speed)
- Foreline pressure for diffusion pump MSDs
- Analyzer chamber pressure (vacuum) for MSDs with the optional G3397B Micro-Ion Gauge Controller

The LCP can also display these data.

Venting the MSD

A program in the data system guides you through the venting process. It turns off the GC and MSD heaters and diffusion pump heater or the turbo pump at the correct time. It also lets you monitor temperatures in the MSD and indicates when to vent the MSD.

The MSD *will* be damaged by incorrect venting. A diffusion pump will backstream vaporized pump fluid onto the analyzer if the MSD is vented before the diffusion pump has fully cooled. A turbo pump will be damaged if it is vented while spinning at more than 50% of its normal operating speed.



Scheduled maintenance

Task	Every week	Every 6 months	Every year	As needed
Tune the MSD				X
Check the foreline pump oil level	X			
Check the calibration vial(s)		X		
Replace the foreline pump oil*		X		
Replace the diffusion pump fluid			X	
Check the dry foreline pump				X
Change the dry foreline pump tip seal			X	
Change the foreline pump exhaust filter				X
Clean the ion source				X
Check the carrier gas trap(s) on the GC and MSD				X
Replace the worn out parts				X
Lubricate sideplate or vent valve O-rings†				X
Replace CI Reagent gas supply				X
Replace GC gas supplies				X

* Every 3 months for CI MSDs using ammonia reagent gas.

† Vacuum seals other than the side plate O-ring and vent valve O-ring do not need to be lubricated. Lubricating other seals can interfere with their correct function.

