

# UV/Vis Spectrophotometer



# UV/Vis Spectrophotometer

LabTech's UV-Vis spectrophotometer has been synonymous with excellence and high performance. It is the core of powerful UV-Visible systems for diverse applications and is suitable for environmental, pharmaceutical, life science, agricultural, and clinical lab applications as well as in routine methods found in:

- Photometric measurement
- Quantitative analyses
- Kinetics
- Spectrum scanning
- Multiple components analysis, etc.



Pharmaceutical analysis



Life science



Agriculture



Food Safety



Environmental Monitoring



Geology



Higher education and research



Inspection and Quarantine

## Excellent Performance

- Streamline surface avoiding sample splashing into internal space
- Real time symmetric double beams system
- Wide wavelength range from 190nm to 1100nm
- Five slits: 0.5nm, 1nm, 2nm, 3nm, and 5nm
- High efficient plane holographic grating with precision sine drive mechanics
- Compact optical path and electronics systems with small footprint
- Few moving parts in the system guaranteeing the highest stability
- Quartz overcoating and sealed optics are prevented from the exposure to corrosive environments
- Light source records working time automatically and is easily replaced without adjustment
- Automatic six-position cell holder enormously shorten sample exchange time
- Intellectual self-checking function is convenient for trouble shooting and maintenance
- High degree automation: automatic wavelength positioning, automatic wavelength calibration, automatic light switch, automatic sample cell switching, automatic current correction, and automatic instruments parameters recording
- Support standalone and PC control for diverse applications
- Various sample cell and holders
- Powerful software with package for biotest and water quality test



# Excellent Performance

## Real Double Beam System

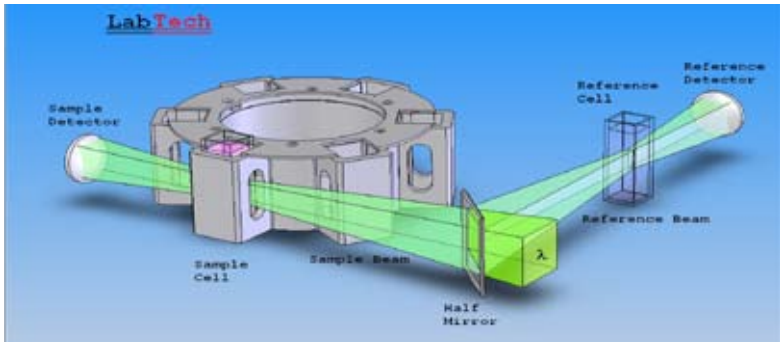

- Real-time calibration
- Stable performance
- High scan speed without distortion

## Crossed C-T Mode

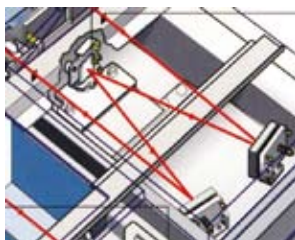

- High efficient plane holographic grating
- High accurate sinusoidal grating driving technique
- Optical parts with SiO<sub>2</sub> overcoating
- Sealed monochromator
- Autoswitch of light source
- Stray light: 0.03%T

## Automatic Six-position Cell Holder



- Capacious sample compartment can hold up to 100mm cell
- Various of cell holders can be selected for different application
- Auto rotary six-position cell holder, shorten the sample exchange time
- Entrance port and exit ports of the light beam in the sample chamber are protected by quartz window, to prevent the optical system from contamination.

## Unique Mechanical Design

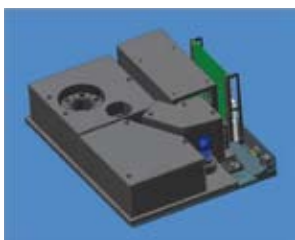

- Sealed optical system, air contamination resistant
- Dust-proof, damp-proof, anticorrosive
- Stable circuit
- Low interior heating dissipation does not interfere optical parts
- High efficiency, low power consumption
- Effective anti-external interference
- Extremely low background noise

## High-quality Components



- Most of key components are chosen from the world's best manufacturers such as deuterium lamp, silicon photodiode detector and holographic grating
- Careful selection of these components ensures the instruments' reliability, accuracy and long lifespan

## Various Cells



Satisfy different application requirements



# User friendly Interface

## Powerful Software



### Spectrum scanning

- Sample characteristics can be scanned in the wavelength range of 190 ~ 1100nm, spectral curve range can be arbitrarily set
- Minimum sampling interval of 0.05nm, three grades of scanning speed: fast, medium and slow
- Comprehensive spectrum data processing technology: the spectral curve data tracking, range reset, peak detection, spectral transform, mathematical calculations, and multiple spectra superimpose
- Parallel data module designed to achieve up to 100 spectra data processing, storage, and review at anytime

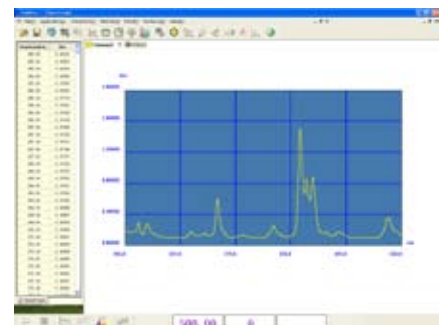

### Photometric measurement

- The photometry provides 10 optional wavelengths for users to measure the absorbance or transmittance

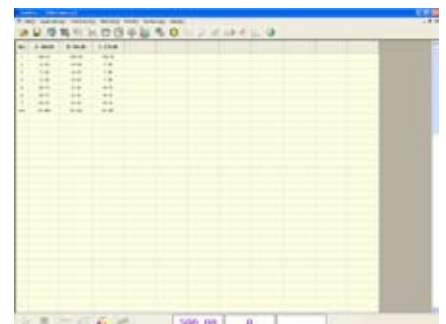

### Kinetic measurement

- Single-wavelength sample scanning measurement to analyze the chemical reaction process over time.
- The measurement time, the sampling interval (minimum 0.1s), the photometric range can be arbitrarily set
- Spectral data processing technology can reset the display range, track data, detect peak, and transform spectrum

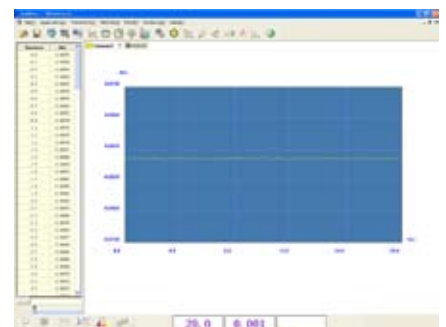

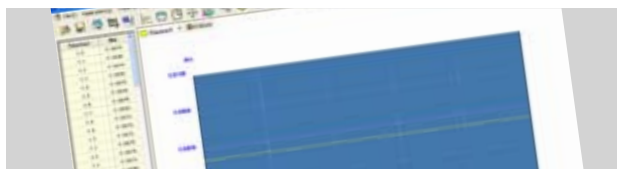

# Powerful Software

## Quantitative determination

- Maximum input standard of 20 points with the method of least squares regression. Linear, linear zero-crossing, secondary, second over zero are optional for curve fitting. Curve regression is more accurate
- Sample analysis with double correction of reagent blank and sample blank double correction
- Analytical methods

Single wavelength standard coefficient method  
Dual-wavelength K-ratio method  
Dual wavelength equal absorption point method  
Three-wavelength method

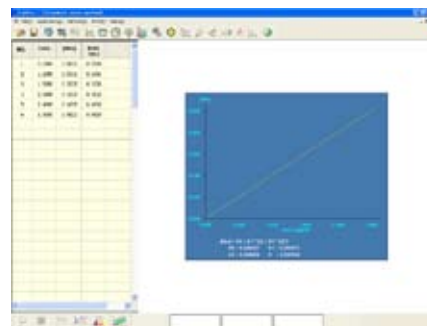

## Multi component analysis

- Mathematical filtering method and mathematical equation simulation
- Concentrations of mixed 10 fractions in the sample can be analyzed without the separation process
- Simple operation, rapid analysis, and accurate results provide an innovative detection method for the direct determination of the mixture
- Widely used in various fields of medicine, food, fuel, paint, etc

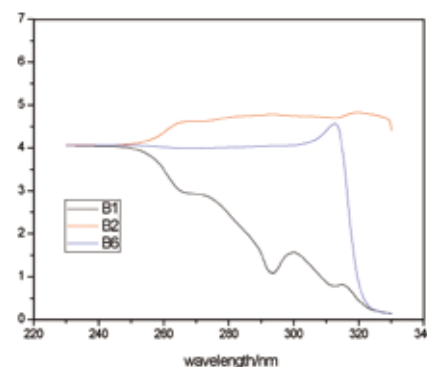

## Software package for biochemical test and water quality test

Providing experimental methods of protein detection, water testing analysis, etc. for users to reduce the user query and parameters set. In addition, providing users with the "customized" option to arbitrarily set and save parameters based on experimental needs.

## Powerful data processing abilities

- Spectrum analysis
- Tracing date. Showing the position of current measuring point
- Detecting peak and valley. Intensity of peak and valley is presented in the table, while spectrum is shown.
- Transferring spectrum Abs-T% conversion, smooth, logarithmic, fourth derivative calculation
- Arithmetical operation. Four arithmetic operations such as addition, subtraction, multiplication and division to deal with measurement data

## Printing report

Save and print each analysis report

## Powerful data storage

- 32-bit processor, more data storage capacity
- Local 32M
- Analyzed data can be saved into mobile hard drive through USB interface adapter, data transmission is more convenient, and more data storage capacity

# UV Power

LabTech's UV Power UV-Vis spectrophotometers are the core of powerful UV-Visible systems for the diverse needs and suitable for environmental, pharmaceutical, life science, agricultural, and clinical lab applications as well as routine applications such as spectrum scanning, photometric measurement, kinetic, quantitative analysis, and multiple components analysis etc.

It offers fast scanning, excellent sensitivity, exceptional ruggedness and reliability, minimum maintenance, and excellent optical performance. Standard automatic 6-position cell holder, double beam optical system, five slit types, 0.5nm, 1nm, 2nm, 3nm, and 5nm, powerful and user friendly software provides packages for water quality test and biochemical test. Standalone and PC control modes ensure flexible operation.



## Technical Parameters

Model	UV Power
Optical System	C-T monochromator, Holographic grating
	Double Beam
Wavelength Range	190-1100nm
Bandwidth	0.5nm/1nm/2nm/3nm/5nm
Photometric Method	Transmittance, Absorbance, Energy
Wavelength Accuracy	±0.3nm
Wavelength Repeatability	±0.1 nm
Absorbance Range	-3~3Abs
Photometric Accuracy	±0.002A(0~0.5A), ±0.004A(0.5~1A), ±0.3%T
Photometric Repeatability	≤0.001A(0~0.5A), ≤0.002A(0.5~1A), 0.1%T
Wavelength Scan Speed	Adjustable(Fast, Middle, Low)
Stray Light	≤0.03% T
Baseline straightness	±0.001A
Drift	≤0.0002A/h (500nm, 0A)
Noise	±0.0002A (500nm, P~P)
Detector	Si-Photodiode
Light Source	Halogen tungsten / Deuterium lamp (Auto-switch)
Cell Holder	Automatic six-position cell holder
Display	320×240 pixel, LCD
Control Mode	PC /Local control
Dimensions	W500xD475xH 245mm
Weight	22Kg

# UV9100 Series

LabTech's UV9100 range of UV-Vis spectrophotometers has been synonymous with excellence and high performance. The range is ideal for use as your own primary reference UV-Vis spectrophotometer in routine laboratories where reliability and ease of use are vital. It has been widely used for applications in commodity inspection, quality control, method developments, research institutes etc.

It offers advanced specifications, high efficient performance with excellent stability and repeatability. Double beam optical system, optional five slits 0.5nm, 1nm, 2nm, 3nm, and 5nm. Standard automatic 6-coupled cell holder. Powerful and user friendly software provides water quality test package for your application. Standalone and PC control modes ensure flexible operation.



## Technical Parameters

Model	UV 9100 A	UV 9100 B	UV 9100 C	UV 9100 D
Optical System	C-T monochromator, Holographic grating			
	Double Beam			
Wavelength range	190 nm ~ 1100 nm			
Spectrum bandwidth	2nm	1nm, 2nm	0.5nm, 2nm	0.5nm, 1nm, 2nm, 3nm, 5nm
Photometric method	Transmittance, Absorbance, Energy			
Absorbance range	-3 ~ 3Abs			
Wavelength Accuracy	±0.3nm			
Wavelength Repeatability	0.1nm			
Photometric Accuracy	±0.002A(0~0.5A), ±0.004A(0.5~1.0A), ±0.3%T			
Photometric Repeatability	≤0.001A(0~0.5A), ≤0.002A(0.5~1.0A), ≤0.1%T			
Stray Light	≤0.05% T			
Baseline straightness	±0.001A			
Drift	≤0.0003A/h (500nm, 0A)			
Noise	±0.0002A (500nm, P-P)			
Scan speed	Adjustable(Fast, Middle, Low)			
Detector	Si-Photodiode			
Light source	Halogen tungsten lamp / deuterium lamp (Auto-switch)			
Cell holder	Automatic six-position cell holder			
Display	320 x 240 pixels, LCD			
Control mode	Local/PC control			
Dimensions	W500xD475xH 245mm			
Weight	22Kg			

# UV8100 Series

LabTech's UV8100 range of UV-Vis spectrophotometers provides you flexible and high efficient operation with excellent stability and repeatability. Large LCD and friendly interface make the operation extremely easy. It is classical and economical and especially suitable for daily routine QA/QC analysis, production analysis, as well as for more specialized applications.

It offers split beam optical system, standard automatic 6-coupled cell holder, optional five slits 0.5nm, 1nm, 2nm, 3nm, and 5nm, powerful software suitable for photometric measurement, spectrum scanning, quantitative determination, kinetic measurement, multi component analysis, data processing etc. Standalone and PC control modes ensure flexible operation.

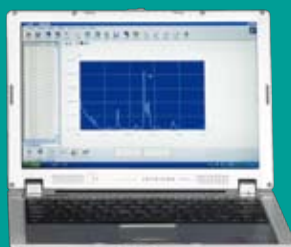

## Technical Parameters

Model	UV 8100 A	UV 8100 B	UV 8100 C	UV 8100 D
Optical System	C-T monochromator, Holographic grating			
	Split Beam			
Wavelength range	190 nm ~ 1100 nm			
Spectrum bandwidth	2nm	1nm, 2nm	0.5nm, 2nm	0.5nm, 1nm, 2nm, 3nm, 5nm
Photometric method	Transmittance, Absorbance, Energy			
Absorbance range	-3 ~ 3Abs			
Wavelength Accuracy	±0.3nm			
Wavelength Repeatability	0.2nm			
Photometric Accuracy	±0.002A(0~0.5A), ±0.004A(0.5~1.0A), ±0.3%T			
Photometric Repeatability	≤0.001A(0~0.5A), ≤0.002A(0.5~1.0A), ≤0.1%T			
Stray Light	≤0.05% T			
Baseline straightness	±0.001A			
Drift	≤0.0005A/h (500nm, 0A)			
Noise	±0.0002A (500nm, P-P)			
Scan speed	Adjustable(Fast, Middle, Low)			
Detector	Si-Photodiode			
Light source	Halogen tungsten lamp / deuterium lamp (Auto-switch)			
Cell holder	Automatic six-position cell holder			
Display	320 x 240 pixels, LCD			
Control mode	Local/PC control			
Dimensions	W500xD475xH 245mm			
Weight	22Kg			



# BlueStar Series

LabTech's BlueStar range UV-Vis spectrophotometer with a fixed bandwidth of 1 nm or 2nm is a high-performance, reliable, and exceptional value instrument.

It is available for both local and PC control, standard single cell, powerful software suitable for photometric measurement, spectrum scanning, quantitative determination, kinetic measurement, multi component analysis, data processing etc.

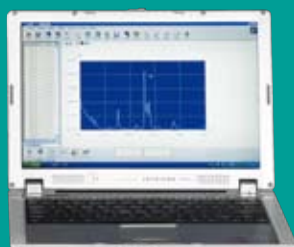

## Technical Parameters

Model	Bluestar A	Bluestar B
Optical System	C-T monochromator, Holographic grating	
	Split Beam	
Wavelength range	190~1100nm	
Spectral bandwidth	2nm	1nm, 2nm
Wavelength accuracy	±0.8nm	
Wavelength repeatability	0.2nm	
Absorption range	-3~3Abs	
Photometric accuracy	±0.002A(0~0.5A), ±0.004A(0.5~1.0A), ±0.3%T	
Photometric repeatability	≤0.001A(0~0.5A), ≤0.002A(0.5~1.0A), ≤0.15%T	
Stray light	0.05%T	
Baseline straightness	0.002A	
Wavelength scan speed	Adjustable(Fast, Middle, Low)	
Drift	≤0.0005A/h (500nm,0A)	
Noise	±0.0002A (500nm, P-P)	
Detector	Si-Photodiode	
Light Source	Halogen tungsten/Deuterium lamp (Auto-switch)	
Cell holder	Standard 10mm cell holder/optional 6-position cell holder	
Control Mode	Local/PC Control	
Display	320 x 240 pixels, LCD	
Control mode	Local/PC control	
Dimensions	W500xD475xH 245mm	
Weight	22Kg	



# Accessories

## Multiple Cells And Cell Holders



Cells/Cuvettes

Quartz, Glass, Long pathlength cells available



Thermostatic cell holder



Automatic six-position 10mm cell holder



Long pathlength cell holder



Single cell holder



Micro volume cell holder



Solid sample holder



Flow cell

# LabTech

WWW.LABTECHUS.COM

**LabTech.** Your reliable laboratory solution provider. LabTech is a leading manufacturing company with skill and passion devoted to provide advanced laboratory solutions to the analytical community. We are located in Hopkinton, Massachusetts USA, with facilities in Italy and China. Incorporated with global branches, LabTech is organized into R&D, production, marketing & sales and customer support. Major LabTech products include organic/inorganic sample preparation systems and laboratory cooling/heating/temperature control equipments. With knowledgeable scientists and experienced engineers, our R&D team has developed and released a series of new lab equipments and instruments dedicated to the modern analytical laboratories. With all of these accomplishments and our endless research and development efforts, we are proud to be your professional partner.



## **LabTech, Inc.**

114 South Street, Hopkinton MA USA

Tel: +1 508 435 5500 Fax: +1 508 435 5595

www.labtechus.com - email: support@labtechus.com