



API 4000 LC/MS/MS

Site Planning Guide

**P/N 1002198D
May 2002**

This document contains information proprietary and confidential to MDS SCIEX, a division of MDS Inc., and is for customer use in the operation and maintenance of MDS SCIEX equipment or is for vendor use in the specification, fabrication, and manufacture of MDS SCIEX designed component parts. Any other use, disclosure to third parties, or reproduction of the information contained herein is strictly forbidden, except as MDS SCIEX may authorize in writing.

Equipment that may be described in this document is protected under one or more patents filed in the United States, Canada, and other countries. Additional patents are pending.

Software that may be described in this document is furnished under a license agreement. It is against the law to copy, modify, or distribute the software on any medium, except as specifically allowed in the license agreement. Furthermore, the license agreement may prohibit the software from being disassembled, reverse engineered, or decompiled for any purpose.

Portions of this document may make reference to other manufacturers' products, which may contain parts that are patented and may contain parts whose names are registered as trademarks and/or function as trademarks. Any such usage is intended only to designate those manufacturers' products as supplied by Applied Biosystems/MDS SCIEX for incorporation into its equipment and does not imply any right and/or license to use or permit others to use such product names as trademarks.

All products and company names mentioned herein may be the trademarks of their respective owners.

Applied Biosystems/MDS SCIEX makes no warranties or representations as to the fitness of this equipment for any particular purpose and assumes no responsibility or contingent liability, including indirect or consequential damages, for any use to which the purchaser may put the equipment described herein, or for any adverse circumstances arising therefrom.

Applied Biosystems/MDS SCIEX is a joint venture between Applera Corporation and MDS SCIEX, the instrument technology division of MDS Inc.

For Research Use Only. Not for use in diagnostic procedures.

Equipment built by MDS SCIEX, a division of MDS Inc.,
at 71 Four Valley Dr., Concord, Ontario, Canada. L4K 4V8.

MDS SCIEX and Applied Biosystems are ISO 9001 registered.

© 2001, 2002 Applied Biosystems/MDS SCIEX, Joint Owners.

All rights reserved.

Printed in Canada.



Table of Contents

About this Manual	1
International Standards	2
Federal Communications Commission Compliance	2
International Compliance	2
Customer Site Setup Check List	3
Customer Responsibilities	3
The API 4000 Instrument	6
Introduction	6
Connections	7
System Requirements	8
Weights and Dimensions	8
Room Dimensions	9
Operating Environment	10
Electrical Requirements	11
Gas Requirements	12
Exhaust Requirements	15
Drain Vessel Considerations	16
Computer Communications Cable Layout Requirements	17
Analyst Computer System Requirements	17
Recommended Supplies	18
Customer-Supplied Equipment and Facilities	19
Solvents	19
Gases	19
Electrical	19
Regulators	20
Ventilation	20
Appendix A	21
Line Voltage Conditioning	21
Line Input Circuits	21

About this Manual

This site planning guide contains information intended to familiarize customers with the necessary preparations and procedures for installing the API 4000 product and associated peripherals.

The site planning guide contains detailed descriptions of the requirements for laboratory layout and required customer supplies.

Within the scope of this manual, the following conventions are used:



WARNING! Indicates an operation that may cause personal injury if precautions are not implemented.



WARNING! Indicates an operation that may involve flammable compounds.

CAUTION! Indicates an operation that may cause damage to the instrument if precautions are not implemented.

NOTE: Emphasizes significant information in a procedure or description.

International Standards

Federal Communications Commission Compliance

This equipment has been tested and found to comply with the limits for a Class A digital device, pursuant to Part 15 of the Federal Communications Commission Compliance (FCC) rules. These limits are designed to provide reasonable protection against harmful interference when the equipment is operated in a commercial environment. This equipment generates, uses, and can radiate radio frequency energy and, if not installed and used in accordance with the operator's manual, can cause harmful interference to radio communications. Operation of this equipment in a residential area is likely to cause harmful interference in which case you will be required to correct the interference at your own expense. Changes or modifications not expressly approved by the manufacturer could void your authority to operate the equipment.

International Compliance

API 4000 LC/MS/MS instruments are in compliance with the following standards:

- EN 61326-1:1997
- EN 61010-1, EN 61010-2-061
- Class A of CISPR publication 11 and EN 55011:97
- IEC 1000-3-3, IEC 1000-4-2, IEC 1000-4-3, IEC 1000-4-4, IEC 1000-4-5, IEC 1000-4-6, IEC 1000-4-8, and IEC 1000-4-11
- CE Mark Declaration of Conformance is included with the instrument
- CSA C22.2 No. 1010.1-92, CSA C22.2 No. 1010.1-2-061:1995
- UL 3101-1
- FCC 15A Class A

Customer Site Setup Check List

Customer name _____

Purchase Order number _____

Customer Service Representative
Name and number _____

Date _____

Customer Responsibilities

Requirement	OK	Preinstallation Action Required
Lab Requirement and Supplies		
A moveable bench for the API system or a fixed bench with 1 m (3.3 ft) of rear clearance and sufficient space underneath for the roughing pump(s).		
A bench for the data acquisition workstation, located within 2 m (6.6 ft) of the main console.		
One liter (1 L) quantities of HPLC or MS grade methanol, acetonitrile, and water.		
Tubing fittings required to connect any LC equipment to the API unless the equipment was sold by Applied Biosystems or was part of an Applied Biosystems designed and distributed workstation.		
Space for benches and supplies		
Gas Requirement (three separately regulated gas lines with shut off valves and fittings)		
Gas 1 and Gas 2 – Zero grade air, delivery pressure at 100 psig, flows up to 17 L/min.		
Source exhaust pump – Oil-free air at < 50 psig, flows up to 6 L/min (air or N ₂)		
Curtain and CAD Gas – UHP nitrogen (99.999%) or gas generators with impurities that are known not to negatively impact performance, delivery pressure at 60 psig, flows up to 5 L/min.		

Requirement	OK	Preinstallation Action Required
Environmental Requirements		
API 4000 mass spectrometer: ambient temperature of 15 °C to 30 °C (stable within ±2 °C) and relative humidity from 20 to 80%, noncondensing.		
Roughing pump(s): ambient temperature of 15 °C to 30 °C (stable within ±2°C) and relative humidity from 20 to 80%, noncondensing.		
Venting Requirements		
Two positive flow vents with 3.2 cm (1.25 in) OD smooth fitting located within 1.5 m (5 ft) of the roughing pump(s) outlets or two mist filters.		
One positive flow vent with sufficient tubing to loosely couple the vent to the source exhaust drain vessel supplied by Applied Biosystems/ MDS SCIEX.		
Safety Requirements		
Gas cylinders mounted to meet local safety standards.		
Gas delivery lines as required by local safety standards.		
Ventilation requires a vent to remove gases from ion source exhaust.		
Preparation of Samples		
Test samples should be ABD P/N 401936 received and refrigerated.		
Data Acquisition Workstation		
Data acquisition workstation from Applied Biosystems/MDS SCIEX.		
Power Requirements		
Two separate, 220 VAC (207-242 VAC), 15 amp circuits at 50/60 Hz, each with two NEMA 6-15R receptacles (four in total) located no more than 1.8 m (6 ft) from the bench. These service the API 4000 mass spectrometer and the roughing pump(s).		

Comments

The following sign-off acknowledges that the *Site Planning Guide* has been read and that the site has been prepared and set up according to the specifications in this document, with the limitations noted in the Preinstallation Action Required column.

Customer Signature _____

Title _____

Date _____

NOTE: Extra charges will apply if the site is not set up to specification or extra parts are required.

Customer Service Representative Responsibilities

The Customer Service Representative for site set up and installation will:

1. Supply all fittings, plugs, tubing, and cables required to connect the API system to the lab vents, electrical receptacles, and regulators, provided they are within the maximum distances specified in this site planning guide.
2. Test and qualify the API system to the specifications in the installation test documents.
3. Assemble and set up any Applied Biosystems/MDS SCIEX benches, if ordered with the instrument.
4. *Only* set up Applied Biosystems/MDS SCIEX supplied and manufactured LC equipment.
5. *Only* connect and ensure RS-232 communications with peripheral devices *unless* they are part of a workstation.

The Customer Service Representative for site set up and installation *will not*:

1. Supply regulators, shut off valves, electrical receptacles, solvents, or gases.
2. Supply LC fittings or tubing *unless* the equipment was sold by Applied Biosystems or was part of an Applied Biosystems designed and distributed workstation.

The API 4000 Instrument

The API 4000 LC/MS/MS instrument, in addition to housing a mass spectrometer, provides connection panels for gas inputs and exhaust, and electronic interfaces for the data acquisition system.

Introduction

The API 4000 LC/MS/MS instrument is a Liquid Chromatography (LC) Mass Spectrometer (MS), which incorporates an Atmospheric Pressure Ionization (API) ion source.



API 4000 mass spectrometer– front view

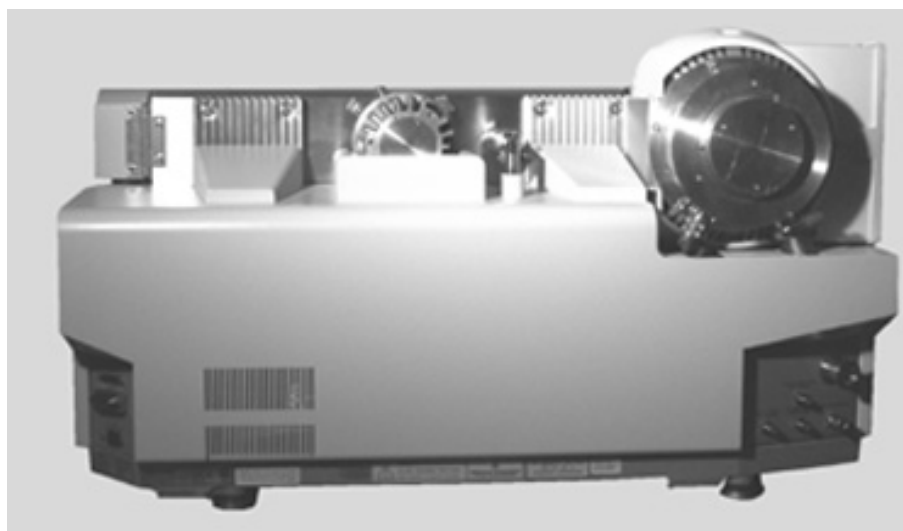

API 4000 mass spectrometer–rear view

Connections

Electric power, gas, and exhaust connections to the instrument are located on the two rear bulkheads, which are positioned on the rear corners of the mass spectrometer.

The gas and vacuum panel is located on the back of the instrument, closest to the ion source housing. This panel contains the connections for the curtain gas supply, Gas 1/Gas 2 supply, source exhaust supply, and source exhaust waste out. See the *Gas and Vacuum Panel* figure below.



Gas and vacuum panel

The interface connection panel contains the connections for the main power connection (207-242 VAC at 50/60 Hz), the Analyst computer interface, an RS-232 interface, and an Auxiliary I/O port; see the *Interface Connection Panel* figure below.

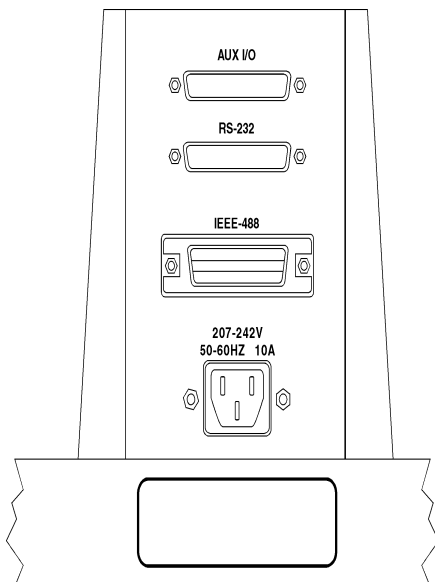

Interface connection panel

System Requirements

Weights and Dimensions

The API 4000 mass spectrometer is 130 cm (53 in.) long by 50 cm (20 in.) wide by 52 cm (21.5 in.) high. This instrument weighs approximately 136 kg (299.2 lb), excluding the roughing pump(s) and the Line Adjustment Transformer (LAT) option.

The customer should supply a bench capable of supporting a minimum weight of 242 kg (529 lb). The minimum suggested bench is 75 cm (30 in.) wide by 150 cm (60 in.) long by 75 cm (30 in.) high. In addition, the bench should have wheels for optimum operation and service access. The optional API custom bench is the recommended bench. See the *Suggested bench height* figure.

The roughing pump weighs approximately 36 kg (79 lb) and is 28 cm (11 in.) high by 16.5 cm (6.5 in.) wide by 50.8 cm (20 in.) long. For API 4000 instruments with two roughing pumps, each pump weighs approximately 25 kg (55 lb) and is 50 cm (20 in.) high by 24 cm (10 in.) wide by 52 cm (20.5 in.) long. The pump(s) should be located underneath the API instrument on the mounting or damping plates included with the special bench, but may be positioned on the floor within 1.5 m (5 ft) of the unit.

The Line Adjustment Transformer (LAT) option weighs approximately 15 kg (33 lb) and is 20 cm (8.2 in.) high by 20 cm (8.2 in.) wide by 27.5 cm (11.5 in.) long. The Line Adjustment Transformer (LAT) option should be located behind the instrument bench or on the special bench shelf.

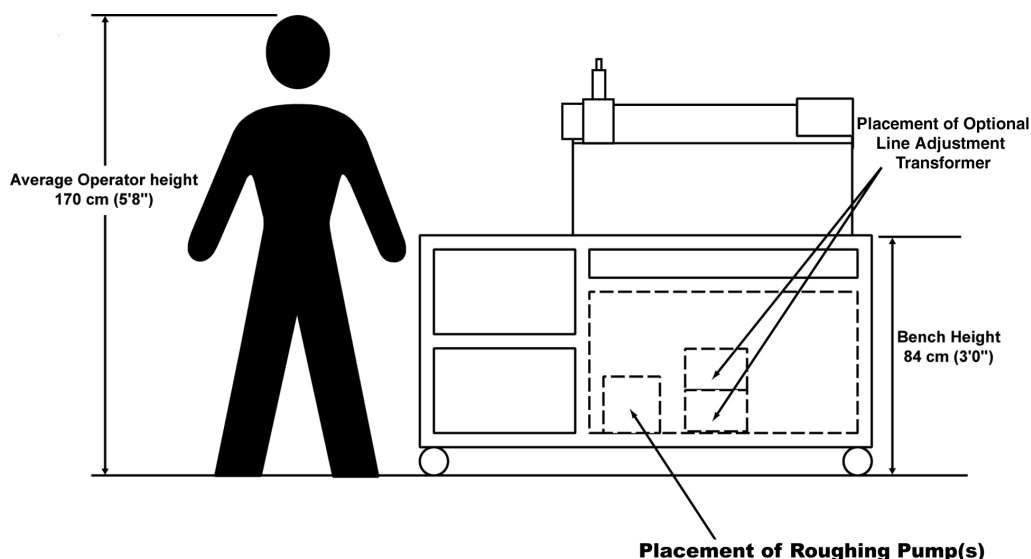

Suggested bench height

Room Dimensions

At the time of service, the customer must provide the Customer Service Representative with adequate access around the instrument. Provisions should be made for clearance of approximately 1 m (3.3 ft) to any one side of the unit, as necessary.

NOTE: The custom bench option is the recommended bench. Use of wall-mounted, or fixed benches will require custom installation.

For purposes of soundproofing, it is highly recommended that a softwall be located 1 m behind the instrument or that you order a soundproof panel.

Suggested Room Layout

While the recommendations for room layout are flexible, the recommendations for operating conditions should be followed as closely as possible to ensure proper and safe equipment operation.

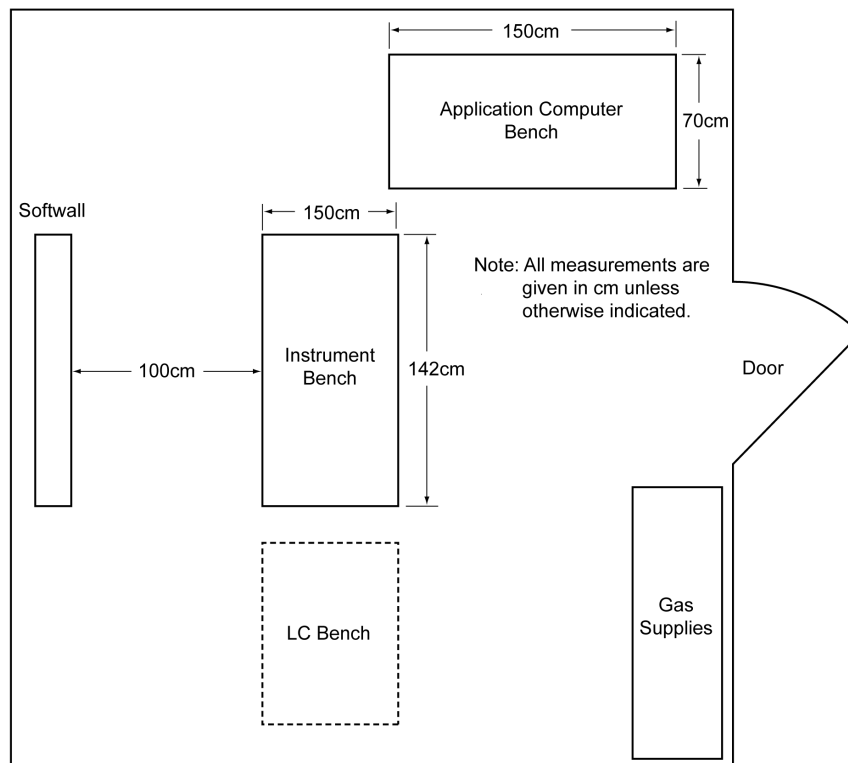

The instrument bench requires a minimum size of 71 cm x 142 cm.
 The Application Computer Bench dimensions are determined by the bench manufacturer but recommended dimensions are given as 70 cm x 150 cm.
 If desired, the gas supplies could be located external to the laboratory.

Top view of the suggested room layout

Operating Environment

The site environment should be kept clean and generally dust-free. High standards of cleanliness are expected. The instrument should be located in an area that is:

- Free of smoke and corrosive fumes
- Not prone to excessive vibration
- Out of direct sunlight
- Away from radiators

Mass Spectrometer

This instrument complies with Pollution Degree 2; Installation Category 2, Electrical Insulation requirements. To ensure the proper operating conditions for the instrument, the environmental conditions must be maintained within ± 2 °C in the range of 15 °C and 30 °C (59 °F to 86 °F) with a relative humidity between 20 and 80% noncondensing.

An air conditioning unit with a capacity of 2550W (8700 Btu/h) is required for this API system including the mass spectrometer, roughing pump(s), and the heat load from the TurboIonSpray or Nebulizer heater.

Operation of the instrument above 2000 m (6500 ft) above sea level is not recommended.

Roughing Pump(s)

To ensure proper operation of the roughing pump(s), the ambient temperature must be maintained between 15 °C and 30 °C (59 °F to 86 °F), with a relative humidity of 20 to 80% noncondensing.

NOTE: It is important that the roughing pump(s) not be put in an enclosed area. Without proper ventilation, it will fail prematurely or shut down from overheating, and cause severe damage to the instrument.

Electrical Requirements

Applied Biosystems/MDS SCIEX recommends using two separate, 220 VAC (207-242 VAC), 15 amp circuits at 50/60 Hz to supply power to the following items:

- API main console
- Rouging (backing) pump

The Line Adjustment Transformer (LAT) option, P/N WC014179 is the recommended means of supplying the required voltage if the 207-242 VAC at 50/60 Hz specification cannot be met. If the line voltage fluctuates by more than 5% during a 24 hour period and falls out of specified values, a power conditioner may be needed. Refer to *Appendix A*.

In North America, use 6-15R receptacles and 6-15P plugs. Outside of North America, use local standardized power receptacles and plugs. A minimum of three electrical outlets are required for the computer equipment. Consult the respective manufacturer's documentation for specifications.

Various outlets are required for LC pumps, autosamplers, Analog-to-Digital Converter boxes and ultraviolet (UV) detectors. The respective manufacturers' specifications contain this information.

Gas Requirements

The API 4000 instrument requires several types of input gas. The recommended purities and pressures of these input gases should be adhered to for proper operation of the instrument. The stated gas purities are given as required at the instrument.

NOTE: When switching gas sources while the instrument is running, ensure that a steady supply is available as back up. If gas flow stops, the instrument will shut down.

Curtain/CAD Gas Supply

The gas supply for curtain and CAD gas requires an input of UHP (99.999%) nitrogen, with an input pressure of 60 psig and flows up to 5 L/min.

Gas 1 and Gas 2

The gas supply for the Gas 1/Gas 2 connection requires an input of zero air or UHP nitrogen with an input pressure of 100 psig to a maximum of 105 psig and flows up to 17 L/min. Nebulizer and sheath gas are derived from this input. The gas is internally divided and controlled to provide one flow for TurboIonSpray nebulizer gas and heater (turbo) gas, or APCI probe nebulizer gas, and a second flow for cooling and sheath gas.

Source Exhaust Supply

The source exhaust supply requires a regulated input of clean, dry, oil-free air at up to 50 psig and flows up to 6 L/min for the source exhaust (venturi) pump.

Component	Gas	Delivery (psig)	Gas Purity	Flow
Curtain and CAD gas	N ₂	60 psig max	UHP N ₂ (99.999%)	5 L/min
Gas 1 and Gas 2	Zero air/N ₂	100 psig	Zero air	17 L/min
Source exhaust	Clean, dry oil-free air or N ₂	50 psig	Clean, dry oil-free air	6 L/min

Suggested Gas Configurations

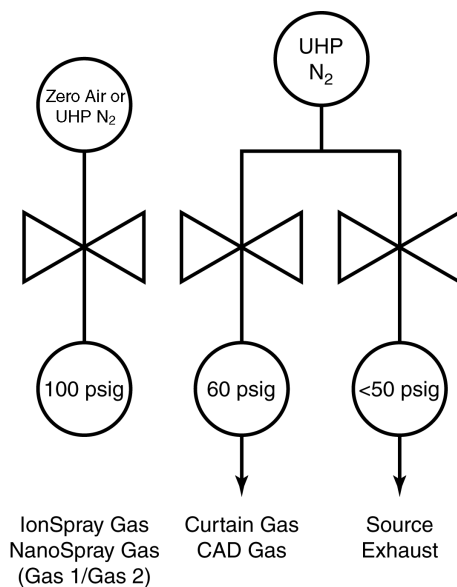

Gas connection schematic using dewar and separate air

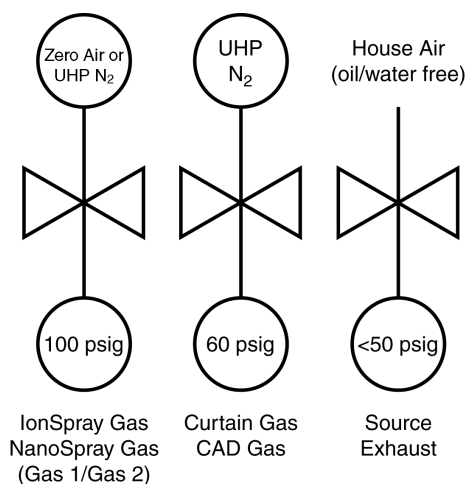

Gas connection schematic using cylinders or separate air and house air

CAUTION! Operation of the API 4000 instrument requires that, if house gases are being supplied, each supply be separately regulated at the instrument.

The preferred gas line connections are compression fittings. Liquid pipe sealant is not acceptable for gas line connections. If threaded fittings must be used, only Teflon tape is acceptable for sealing the threads. Soldered fittings are not acceptable unless the tubing is thoroughly cleaned afterward.

Gas Cylinder Considerations

- Fasten all gas cylinders securely to an immovable bulkhead or to a permanent wall.
NOTE: It is the user's responsibility to permanently install gas supplies that conform to local safety and building codes.
- Ensure that, when gas cylinders are stored in confined areas, such as a room, ventilation is adequate to prevent accumulations that could displace sufficient oxygen to suffocate the user. Move or store gas cylinders only in a vertical position with the valve cap in place.
- Locate gas cylinders away from heat or ignition sources, including heat lamps. Cylinders have a pressure-relief device that releases the contents of the cylinder if the temperature exceeds 52°C (125°F).
- When storing cylinders outside of a building, the cylinders should be stored so that they are protected against temperature extremes (including direct sunlight) and should be stored above the ground on a suitable floor.
- Mark gas cylinders clearly to identify the contents and status (full, empty, etc.).
- Do not attempt to refill gas cylinders.
- Use only approved regulators and hose connectors. Left-hand thread fittings are used for fuel gas tank connections, whereas right-hand fittings are used for oxidant and support gas connections.
- Arrange gas hoses where they cannot be damaged or stepped on and where things cannot be dropped on them.
- Perform periodic gas leak tests by applying a soap solution to all joints and seals.

Exhaust Requirements

Exhaust from the API 4000 instrument originates from the source exhaust and roughing pump(s).

Source Exhaust Pump

During operation, solvent vapors and effluent are exhausted from the vent chamber under the ion source housing by the source exhaust pump (venturi pump) to a 1.27 cm (0.50 in.) barbed fitting. This effluent must be drained to a drain vessel and vented to a fume hood or an outside port. It is the responsibility of the customer to provide the proper plumbing from the drain vessel to the ventilation point.

Roughing Pump Exhaust

The customer will be provided with the installation kit that includes a smoke eliminator (mist filter) for the roughing pump(s). The system includes fittings and tubing to connect the roughing pump(s) to the fume hood or other vents.

Venting System Recommendations

The following are recommendations for a customer-supplied vent system that may be used to vent the roughing pump(s) and the ion source exhaust.

The exhaust flow rate at the instrument (the ability to vent the system) is dependent on the blower provided by the customer, the duct length, the material and the number of elbows (or bends) used. If an excessively long duct system or a system with many bends is used, a stronger blower may be necessary to provide sufficient exhaust volume at the instrument.

Smooth stainless steel tubing should be used instead of flexible stainless steel tubing where flexibility is not required to reduce system friction loss or drag. A length of smooth stainless steel ducting has 20 to 30% less friction loss than a comparable length of flexible ducting. When smooth stainless steel tubing is used, elbows must be used to turn corners. These elbows should turn at an angle of 45 degrees to reduce friction losses, and a minimum number of elbows should be used.

Additional recommendations for the venting system include the following items:

- The duct casing and venting system should be made of materials suitable for temperatures as high as 70 °C (158 °F) and should meet local building standards.
- The vent system should produce a static vacuum of approximately 2 cm (0.75 in) of water.
- The blower should be located as close to the discharge outlet as possible. All joints on the discharge side should be airtight.
- The outlet end of the system should be equipped with a backdraft damper and the necessary precautions should be taken to keep the exhaust outlet away from open windows or inlet vents. The exhaust outlet should extend above the roof for proper dispersal.
- The exhaust end of the system should be equipped with an exhaust stack to improve the overall efficiency of the system.

- The length of the duct that enters the blower must be a straight length and at least ten times the duct's diameter. An elbow entrance into the blower inlet causes a loss in efficiency.
- Make-up air must be in the same quantity as the air exhausted by the system. An airtight lab causes an efficiency loss in the exhaust system.
- The system should be checked to ensure it is drawing properly by placing a piece of tissue near the mouth of the vent.
- The blower must be equipped with a power indicator light located near the instrument to indicate to the operator when the blower is on.

Drain Vessel Considerations

A 10 L (3 gallon) drain vessel is supplied with the instrument. The vessel is made of HDPE and is used to gather the effluent from the ion source housing. The drain vessel can be placed under a fume hood, or a positive flow vent can be loosely coupled with the short vent hose on the vessel to remove the exhaust gases from the laboratory. For loose coupling, the small-diameter vent hose attached to the vessel may be inserted into a large-diameter house exhaust pipe so that air is drawn along with the exhaust waste.

CAUTION! Do not connect the vent fitting on the drain vessel directly to a positive flow vent. The additional vacuum could trip the source exhaust pump pressure switch, indicating that the source exhaust pump is working when it is not, and enable the instrument electronics.



WARNING! The drain vessel should NOT be stored in an enclosed storage area. The drain system should be checked regularly and replaced when necessary.

NOTE: Should it become necessary to replace the drain vessel, the replacement should be made from a material not likely to be attacked by samples being analyzed. Glass or other brittle materials must not be used.

Computer Communications Cable Layout Requirements

The *maximum* recommended distance between the API mass spectrometer and the Analyst computer is 4 m (13 ft). Distances longer than 4 m (13 ft) may be used, but reliable IEEE 488 communication cannot be guaranteed.

A 2 m (6 ft) IEEE 488 cable is included with the API 4000 instrument.

Analyst Computer System Requirements

Computer system requirements may be upgraded from time to time. Please contact your service representative for the current system requirements. Only computers supplied by Applied Biosystems/MDS SCIEX are fully supported; there is no guarantee that customer-supplied computers can be made to work properly. Applied Biosystems/MDS SCIEX may charge customers for any additional time required to make a customer-supplied computer operable.

Where an Ethernet network is used, the customer is responsible for establishing network connections and assigning a unique TCP/IP address to the Analyst computer. The Customer Service Representative will provide the customer with the information required to connect the API 4000 instrument to the Analyst computer. The customer will need to contact their Systems Administrator for the proper TCP/IP address, and any required network connection hardware.

Recommended Supplies

As shown in the *Suggested Room Layout* section, the LC pumps and autosamplers require a movable LC bench for access to the ion source.

The computer equipment may be placed on a fixed bench, provided that access to the API 4000 instrument is not restricted.

The bench space requirements for the pumps, computers, etc. is dependent on the respective manufacturer.

Useful Part Numbers and Suppliers

The following is a list of part numbers for non-Applied Biosystems/MDS SCIEX supplied products and their manufacturers.

Use	Regulators	Manufacturer	Cylinder/ Dewer Gas Regulator P/N	House Gas Regulator P/N
Curtain gas	N ₂ - 60 psig	Matheson (100 psig max.)	SP-3810-590 (1/4" fitting)	SP-3231 (1/4" fitting)
Gas 1/Gas 2	Air - 100 psig	Matheson (100 psig max.)	SP-3810-590 (1/4" fitting)	SP-3231 (1/4" fitting)
Source exhaust	Air - 50 psig	Matheson (100 psig max.)	SP-3810-590 (1/4" fitting)	SP-3231 (1/4" fitting)

All regulator fittings are 1/4" NPT to 1/4" Swagelok fittings. (Swagelok p/n SS-400-11-4).

Customer-Supplied Equipment and Facilities

The customer is responsible for providing the following supplies while operating the API 4000 instrument.

Solvents

The customer supplies methanol, acetonitrile, and water (all HPLC or MS grade).

Gases

The customer supplies the following gases:

- UHP nitrogen for curtain and CAD gas at 60 psig up to 5 L/min
- Zero air or UHP nitrogen for Gas 1 and Gas 2 at 100 psig up to 17 L/min
- House air or nitrogen at 50 psig up to 6 L/min, oil-free, for the source exhaust (venturi) pump



WARNING! Use qualified personnel for the installation of plumbing and fixtures, and ensure that all installations follow local bylaws and biohazard regulations.

Electrical

The customer will supply the following electrical connections:

- Two 207-242 VAC at 50/60 Hz, single phase, 15 amp circuits with two NEMA 6-15R receptacles and plugs per line for the API 4000 instrument and roughing pump(s).

NOTE: The Line Adjustment Transformer (LAT) option is the recommended means of supplying the required voltage if the specification above cannot be met.

Applied Biosystems/MDS SCIEX does not recommend or specify powerline conditioners.

- Sufficient outlets for autosamplers, LC pumps, and other computer equipment. See manufacturers' specifications for voltage, current, and other requirements.



WARNING! Use qualified personnel for the installation of all electrical fixtures, and ensure that all installations follow local bylaws.

Regulators

Customers must supply the appropriate gas regulators for the gas supplies. The required gas regulators are listed in the *Gas Regulators* table of the *Recommended Supplies* section.

Ventilation

The customer must supply ventilation as required by local bylaws and regulations for the roughing pump(s) and the source exhaust pump. The maximum flow rate of these pumps is a volume less than 30 L/min.

NOTE: For installations where the optional installation kit has been purchased, venting of the roughing pump(s) is not necessary as a smoke eliminator has been included.



WARNING! Use qualified personnel for the installation of plumbing and fixtures, and ensure that all installations follow local bylaws and biohazard regulations.



WARNING! It is strongly recommended that the source exhaust system be used and that the exhaust be safely removed from the laboratory environment.

Appendix A

Line Voltage Conditioning

Line voltage requirements for the API 4000 LC/MS/MS are defined in this site planning guide. These requirements are not stringent and can normally be met by the local electrical supply authority.

Policy

Where the electrical supply does not meet Applied Biosystems/MDS SCIEX requirements, the customer should consult their power supplier or a local consultant on line conditioning apparatus to establish the most effective solution to the problem.

Line Input Circuits

Transients

The API 4000 instrument has line filter circuits that should eliminate the effects of brief transients.

Regulation

The required line voltage regulation is specified in the Electrical Requirements section.

Supply Interruption

An Uninterruptable Power Supply unit (UPS) is required to ensure continuous operation of the instrument in the event of a power supply interruption. A UPS normally includes a battery, a battery charger and an AC to DC inverter which can be both large and expensive. Normally, they are sized to run the instrument for approximately 10 minutes following a power failure, allowing an orderly termination of the work in progress. This type of equipment often includes control of line voltage regulation and additional transient protection.

